

Ion1K, Ion2K & Ion4K™

CLEAN AIR COMPANION

INSTRUCTION MANUAL



Read Manual Before Operating Machine

Table of Contents

Table of Contents	3
Features and Specifications	4
Safety	6
Operation and Maintenance	7
Ion1K Control Panel.....	7
Ion2K, Ion4K Control Panel	7
Operation	8
Maintenance	8
Troubleshooting	9
Parts List	10
Ion1K Parts	10
Ion2K, Ion4K Parts.....	11
Warranty	12

Features and Specifications

PRODUCT DESCRIPTION

The Ion1K, Ion2K and Ion4K are compact machines that electronically charge the air in the room, driving dust and other contaminants rapidly to the ground in a manner that is safe for the user and the environment. These machines do not produce ozone.



Ion4K shown

FEATURES

1. Locking caster wheels (Ion2K and Ion4K models)
2. Pre-filters and main filter protect internal components of machine
3. Multi-speed fan flexible for varying jobsites
4. Simple control panel
5. Sturdy handles for easy transportation

Features and Specifications

Product Specifications			
	Ion1K	Ion2K	Ion4K
Size	14.5" x 19.7" x 22.8" (370 x 500 x 580 mm)	20.5" x 28.7" x 24.4" (520 x 730 x 620 mm)	20.5" x 28.7" x 24.4" (520 x 730 x 620 mm)
Weight	40 lbs (18 kg)	121 lbs (55 kg)	132 lbs (60 kg)
Voltage	230V / 110V	230V / 110V	230V / 110V
Power Consumption	220W	240W	300W
Sound, Low-High Fan	40 - 60 dBA	45 - 60 dBA	50 - 75 dBA
Effective in This Volume of Space	Up to 15,000 ft ³ (420 m ³)	Up to 40,000 ft ³ (1130 m ³)	Up to 70,000 ft ³ (1980 m ³)

Machine Variants			
Region	Serial Number	Voltage	Power Consumption
Domestic (North America)	ION1K-10XXXX	110V	220W
	ION2K-10XXXX	110V	240W
	ION4K-10XXXX	110V	300W
International	ION1K-11XXXX	230V	220W
	ION2K-11XXXX	230V	240W
	ION4K-11XXXX	230V	300W
	ION1K-13XXXX	230V	220W
	ION2K-13XXXX	230V	240W
	ION4K-13XXXX	230V	300W
	ION1K-20XXXX	110V	220W
	ION2K-20XXXX	110V	240W
	ION4K-20XXXX	110V	300W

Safety

GENERAL RULES FOR SAFE OPERATION

READ AND SAVE ALL INSTRUCTIONS FOR FUTURE USE. Before use, ensure operators read and understand this manual. Read and understand labeling on machine and components.

1. **KNOW YOUR EQUIPMENT:** Read this manual carefully to learn equipment applications and limitations, potential hazards associated with this type of equipment. Keep this manual with the equipment it is associated with.
2. **GUARD AGAINST ELECTRIC SHOCK:** The ionizer must be unplugged from the wall socket before any kind of maintenance or service is performed. Never unplug by pulling the cord from the outlet. Pull plug rather than cord to reduce the risk of damage. Keep the cord away from heat, oil, sharp objects, cutting edges and moving parts.
3. **AVOID DANGEROUS ENVIRONMENTS:** Do not use in rain, damp or wet locations, or in the presence of explosive atmospheres (gaseous fumes, dust or flammable materials). Remove from the area any materials or debris that may be ignited by sparks.
4. **CHECK FOR DAMAGED PARTS:** If either filter is damaged, it must be replaced before use. Damaged power cords should be replaced immediately.
5. **USE SAFETY EQUIPMENT:** Always wear PPE as required by local regulations when handling filters as they may contain hazardous dust. Put the used filter in a large plastic bag and seal it for disposal according to local regulations.
6. **USE PROPER FILTERS:** The ionizer must never be used without filters.
7. **REPAIRS:** All service, repair, and trouble-shooting of the ionizer (other than replacing filters) can only to be performed by an authorized service technician.
8. **CLEANING CHASSIS:** Remove dust from the chassis with a HEPA filtered dust collector like National Flooring Equipment's DL2000, DL3000 or DL7000.



WARNING: NEVER USE COMPRESSED AIR TO CLEAN DUST FROM THE IONIZER.



WARNING: THE IONIZER MUST BE CONNECTED TO A GROUNDED SOCKET. NEVER REMOVE THE GROUNDING PIN FROM THE PLUG OR USE THE MACHINE IF THE GROUNDING PIN IS MISSING.

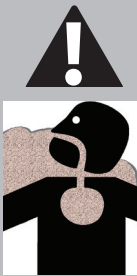

WARNING: GRINDING/CUTTING/DRILLING OF MASONRY, CONCRETE, METAL AND OTHER MATERIALS CAN GENERATE DUST, MISTS AND FUMES CONTAINING CHEMICALS KNOWN TO CAUSE SERIOUS FATAL INJURY OR ILLNESS, SUCH AS RESPIRATORY DISEASE, CANCER, BIRTH DEFECTS OR OTHER REPRODUCTIVE HARM. IF YOU ARE UNFAMILIAR WITH THE RISKS ASSOCIATED WITH THE PARTICULAR MATERIAL BEING CUT, REVIEW THE MATERIAL SAFETY DATA SHEET AND/OR CONSULT YOU EMPLOYER, THE MATERIAL MANUFACTURER/SUPPLIER, GOVERNMENTAL AGENCIES SUCH AS OSHA AND NIOSH AND OTHER AUTHORITIES ON HAZARDOUS MATERIALS. CALIFORNIA AND SOME OTHER AUTHORITIES, FOR INSTANCE, HAVE PUBLISHED LISTS OF SUBSTANCES KNOWN TO CAUSE CANCER, REPRODUCTIVE TOXICITY, OR OTHER HARMFUL EFFECTS. CONTROL DUST, MIST AND FUMES AT THE SOURCE WHERE POSSIBLE. IN THIS REGARD USE GOOD WORK PRACTICES AND FOLLOW THE RECOMMENDATIONS OF THE MANUFACTURER/SUPPLIER, OSHA/NIOSH, AND OCCUPATIONAL AND TRADE ASSOCIATIONS. WHEN THE HAZARDS FROM INHALATION OF DUST, MISTS AND FUMES CANNOT BE ELIMINATED, THE OPERATOR AND ANY BYSTANDERS SHOULD ALWAYS WEAR A RESPIRATOR APPROVED BY OSHA/MSHA FOR THE MATERIAL BEING CUT.

Operation and Maintenance

Ion1K CONTROL PANEL

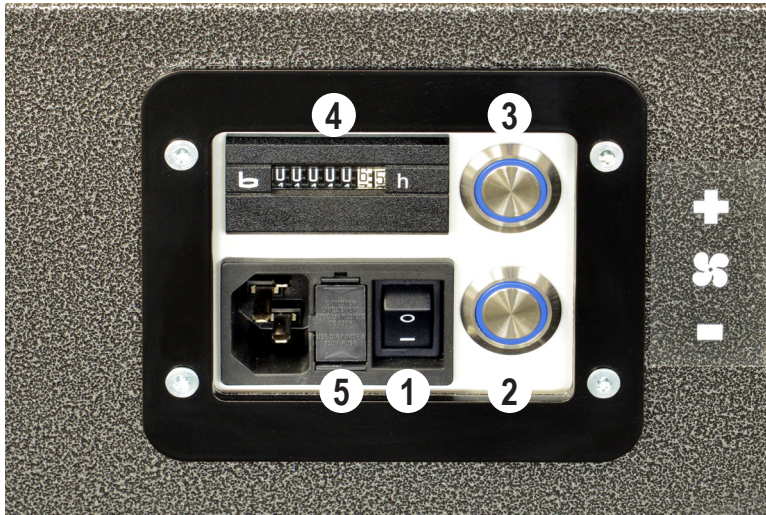

1. Power Switch
2. Fan-Low Speed
3. Fan-High Speed
4. Hour Meter
5. Fuse

Ion2K, Ion4K CONTROL PANEL



1. Power Switch
2. Fan Speed Control
3. Hour Meter
4. Circuit Breaker

Operation and Maintenance



WARNING: BE SURE THE MACHINE IS FIRMLY AND SECURELY PLACED ON A TABLE OR THE FLOOR TO PREVENT THE MACHINE FROM TIPPING OVER DURING PREPARATION AND USE.

OPERATION

1. Set the ionizer near the center of the area being treated. Move power cords away from the active work zone to avoid damage to the cord.
2. Plug the ionizer into an outlet.
3. Press the power switch to ON and select the fan speed.
 - **Ion1K:** Press LOW button for half speed (small rooms), press both LOW and HIGH buttons for full speed.
 - **Ion2K, Ion4K:** Turn control knob to set the desired speed.



WARNING: BEFORE PERFORMING MAINTENANCE, ALWAYS DISCONNECT THE IONIZER FROM POWER TO PREVENT ACCIDENTAL ELECTRIC SHOCK.

MAINTENANCE

Note: The ionizer is not an air cleaner. It has filters that are meant to protect the fan and ionization rods and must be cleaned as often as necessary to maintain airflow through the unit.

- The two pre-filters must be cleaned as often as needed based on air flow.
 - National Flooring Equipment recommends keeping a minimum of four pre-filters (of each type) available to replace during operation as they clog with dust.
 - The pre-filters can be cleaned using a HEPA filtered dust collector like National Flooring Equipment's DL2000, DL3000 or DL7000.
 - Depending on the amount of dust in the environment, the pre-filters may need to be replaced after 1-2 weeks of use.
- Depending on use and dust conditions, the main filter must be replaced a minimum of every six months.
- Remove dust from the chassis with a HEPA filtered dust collector.



WARNING: NEVER USE COMPRESSED AIR TO CLEAN DUST FROM THE IONIZER.



WARNING: REPLACING OR CLEANING THE PRE-FILTERS CAN RELEASE DUST THAT MAY BE HAZARDOUS TO YOUR HEALTH. THE USER SHOULD ALWAYS WEAR PROTECTIVE GLASSES, PROTECTIVE GLOVES AND A BREATHING MASK CONFORMING TO PROTECTION CLASS FFP3 WHEN SERVICING THE FILTERS.

Note: Size of filters vary depending on model.

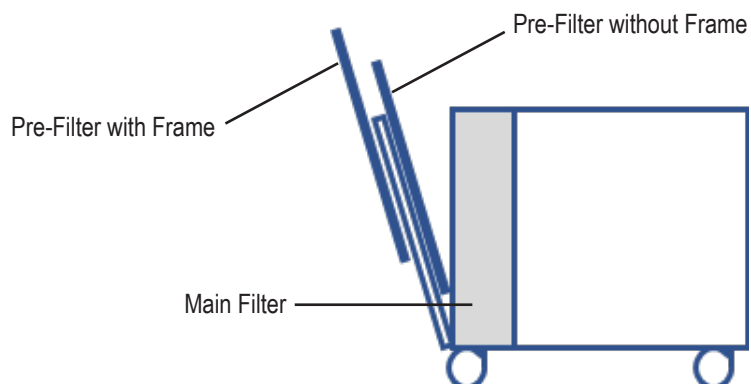

Operation and Maintenance



WARNING: BEFORE PERFORMING MAINTENANCE, ALWAYS DISCONNECT THE IONIZER FROM POWER TO PREVENT ACCIDENTAL ELECTRIC SHOCK.

TROUBLESHOOTING

Problem	Cause	Solution
Ionizer does not start with power switch	No power to unit	Ensure unit is plugged in.
		Ensure circuit breaker for the power source has not been tripped.
		Check fuse or circuit breaker on control panel and replace or reset as needed.
Inefficient ionization	Low airflow from fan	Clean or replace filters.
Fan motor making an unusual noise		Turn off unit immediately and contact NFE for service.
Other problems		Contact NFE for service.

Parts List

Ion1K Parts



405219
Pre-Filter, with Frame, Pack of 10



405218
Pre-Filter, without Frame





405220
Filter, Main



404942
Rod, Ionization

Ion2K, Ion4K Parts

		
404938 Pre-Filter, with Frame, Pack of 10	404937 Pre-Filter, without Frame	404939 Filter, Main

		
404940 Assembly, Caster without Lock	404941 Assembly, Caster with Lock	404942 Rod, Ionization

Warranty

National Flooring Equipment Inc. (referred to as "The Company") warrants that each new unit manufactured by The Company to be free from defects in materials and workmanship in normal use and service for a period of 90 days from date of shipment from The Company to the end user. If shipment to end user is from a Distributor, The Company may extend warranty if the end user can provide documentation of receipt date. Accessories or equipment furnished and installed on the product by the Company but manufactured by others, including but not limited to: engines, motors, electrical components, transmissions etc., shall carry the accessory manufacturers own warranty. Battery warranties are pro-rated over the warranty period. Customer is responsible for the inspection of equipment or parts upon delivery. **Freight damages are excluded from this warranty.**

The Company, at its determination of defect, will repair or replace any product or part deemed to be defective in material or workmanship within specified warranty time period. All product determinations and / or repairs will take place at The Company repair facility or at a certified warranty location designated by The Company. The Company will coordinate and be responsible for all freight expenses associated with valid warranty claims. Freight and shipping expenses associated with abuse or misuse will be back charged to the Distributor/Customer. The Company reserves the right to modify, alter or improve any part / parts without incurring any obligation to replace any part / parts previously sold without such modified, altered or improved part / parts. In no event shall the seller or manufacturer of the product be liable for special, incidental, or consequential damages, including loss of profits, whether or not caused by or resulting from the negligence of seller and / or the manufacturer of the product unless specifically provided herein. **This warranty shall not apply to any products or portions there of which have been subjected to abuse, misuse, improper installation or operation, lack of recommended maintenance, electrical failure or abnormal conditions, and to products which have been tampered with, altered, modified, repaired, reworked by anyone not approved or authorized by the Company or used in any manner inconsistent with the provisions of the above or any instructions or specifications provided with or for the product.** Any and all unauthorized onsite warranty work conducted by unauthorized personnel or any outside person(s), is not covered by The Company unless the work has been pre-authorized by a predetermined manufacturer representative. This warranty excludes wearable parts and/or consumables.

Defective or failed material or equipment shall be held at the purchaser's premises until authorization has been granted by The Company to return or dispose of defective products. Products returned to The Company for inspection must be returned with a manufacturer authorized Return Material Authorization (RMA), and must be packaged to The Company's specifications to avoid damage during shipment. Any unauthorized return of equipment will be declined at the dock by The Company. Any non-approved items returned with approved returned items are subject to rejection and will not be credited. Credit will be issued for material found to be defective upon The Company's inspection based on prices at time of purchase.

TO OBTAIN SERVICE CONTACT NATIONAL FLOORING EQUIPMENT, INC. TOLL FREE AT 800-245-0267 FOR A REPAIR AUTHORIZATION NUMBER. COD FREIGHT RETURNS WILL NOT BE ACCEPTED. FREIGHT COLLECT SHIPMENTS WILL NOT BE ACCEPTED. WARRANTY REPAIRS MUST BE ACCOMPANIED BY DATE OF PURCHASE RECEIPT AND A RETURN/REPAIR AUTHORIZATION NUMBER.

RETURN/REPAIR AUTHORIZATION NUMBER: _____

MACHINE SERIAL NUMBER: _____



9250 Xylon Avenue N • Minneapolis, MN 55445 • U.S.A.
Toll-free 800-245-0267 • Phone 763-315-5300 • Fax 800-648-7124 • Fax 763-535-8255
Web Site: www.nationalequipment.com • E-Mail: info@nationalequipment.com