

5000 RIDE-ON SCRAPER

SERVICE MANUAL



Read Manual Before Servicing Machine

403707 Rev F

Table of Contents

Table of Contents	3
Specifications	4
Safety	5
General Rules For Safe Operation	5
Ride-On Scraper Safety Guidelines	6
Hydraulic Safety	7
Maintenance Schedule	8
Troubleshooting Guide	9
Maintenance	10
Dual Slide Plate Removal	10
Leak Maintenance	10
Check Hydraulic Oil Level	10
Hydraulic Oil Change Out	10
Change Hydraulic Cylinder	11
Change/Remove Hose	11
Change Pump	11
Change Valve	11
Change Wheel Motor	11
Change Rear Wheel	12
Change Caster	12
Change Motor	12
Seat Replacement	12
Remove/Replace Foot Peg	13
Clean Wheel Motor Build-Up	13
Parts List and Diagrams	14
Warranty	31

Specifications

Product Specifications

Width	Length	Height	Weight (Machine Only)	Weight (Fully Weighted)	Power	Speed
24.5" (62 cm)	63" (160 cm)	48" (122 cm)	1,656 lb (751 kg)	2,101 lb (953 kg)	4 HP	Up to 160 ft/min.

Machine Variants

Region	Serial Number	Input Voltage / Frequency	Body Panels
Domestic (North America)	5000-17XXXX	120V / 60 Hz	Silver Vein
International	5000-11XXXX	230V / 50 Hz	Silver Vein
	5000-15XXXX	230V / 50 Hz	Orange
	5000-20XXXX	110V / 50 Hz	Silver Vein

GENERAL RULES FOR SAFE OPERATION

Before use, anyone operating or performing maintenance on this equipment must read and understand this manual, as well as any labels packaged with or attached to the machine and its components. Read the manual carefully to learn equipment applications and limitations, as well as potential hazards associated with this type of equipment. Keep manual near machine at all times. If your manual is lost or damaged, contact National Flooring Equipment (NFE) for a replacement.

Personal

Dress properly and use safety gear.

Do not wear loose clothing; it may be caught in moving parts. Anyone in the work area must wear safety goggles or glasses and hearing protection. Wear a dust mask for dusty operations. Hard hats, face shields, safety shoes, etc. should be worn when specified or necessary.

Maintain control; stay alert.

Keep proper footing and balance, and maintain a firm grip. Observe surroundings at all times. Do not use when tired, distracted, or under the influence of drugs, alcohol, or any medication that may cause decreased control.

Keep hands away from all moving parts and tooling.

Wear gloves when changing tooling. Remove tooling when machine is not in use and/or lower cutting head to the floor.

Do not force equipment.

Equipment will perform best at the rate for which it was designed. Excessive force only causes operator fatigue, increased wear, and reduced control.

Environment

Avoid use in dangerous environments.

Do not use in rain, damp or wet locations, or in the presence of explosive atmospheres (gaseous fumes, dust, or flammable materials). Remove materials or debris that may be ignited by sparks. Keep work area tidy and well-lit - a cluttered or dark work area may lead to accidents. Extreme heat or cold may affect performance.

Protect others in the work area and be aware of surroundings.

Provide barriers or shields as needed to protect others from debris and machine operation. Children and other bystanders should be kept at a safe distance from the work area to avoid distracting the operator and/or coming into contact with the machine. Operator should be aware of who is around them and their proximity. Support personnel should never stand next to, in front of, or behind the machine while the machine is running. Operator should look behind them before backing up.

Do not come within 3 ft. of the machine's perimeter during operation.

Guard against electric shock.

Ensure that machine is connected to a properly grounded outlet. Prevent bodily contact with grounded surfaces, e.g. pipes, radiators, ranges, and refrigerators. When scoring or making cuts, always check the work area for hidden wires or pipes.

Maintenance & Repairs

Begin maintenance work only when the machine is shut down, unplugged, and cooled down.

Use proper cleaning agents.

Ensure that all cleaning rags are fiber-free; do not use any aggressive cleaning products.

Schedule regular maintenance check-ups.

Ensure machine is properly cleaned and serviced. Remove all traces of oil, combustible fuel, or cleaning fluids from the machine and its connections and fittings. Retighten all loose fittings found during maintenance and repair work. Loose or damaged parts should be replaced immediately; use only NFE parts.

Do not weld or flame-cut on the machine during repairs, or make changes to machine without authorization from NFE.

Equipment

Use proper parts and accessories.

Only use NFE-approved or recommended parts and accessories. Using any that are not recommended may be hazardous.

Ensure accessories are properly installed and maintained.

Do not permanently remove a guard or other safety device when installing an accessory or attachment.

Inspect for damaged parts.

Check for misalignment, binding of moving parts, loose fasteners, improper mounting, broken parts, and any other conditions that may affect operation. If abnormal noise or vibration occurs, turn the machine off immediately. Do not use damaged equipment until repaired. Do not use if power switch does not turn machine on and off. For all repairs, insist on only identical NFE replacement parts.

Maintain equipment and labels.

Keep handles dry, clean, and free from oil and grease. Keep cutting edges sharp and clean. Follow instructions for lubricating and changing accessories. Motor and switches should be completely enclosed at all times with no exposed wiring. Inspect cord regularly. Labels carry important information; if unreadable or missing, contact NFE for a free replacement.

Avoid accidental starting; store idle equipment.

When not in use, ensure that the machine is unplugged and breaker is set to OFF. Store in a dry, secured place. Remove tooling when storing, and keep away from children.

Safety

RIDE-ON SCRAPER SAFETY GUIDELINES

Scraping

Do not drive machine along hills or uneven surfaces.

The weight of the machine may become distributed differently if on an uneven surface. Too much of an angle could make the machine unsafe or cause it to tip over. Always keep the front of the machine facing downward while traveling up or down ramps or inclines. Do not run the machine in unsafe environments.

Inspect work area for potential hazards prior to operation.

Observe location of electrical supplies and extension cords.

Do not allow cutting heads to come into contact with any electrical supply or extension cord.

Operator must be seated before starting machine and should stay seated until motor has stopped running.

This machine is equipped with a safety switch under the seat, which requires the operator to be seated before the machine can be operated. Do not attempt the start-up procedure without first being seated on the machine.

Batteries and Chargers

Use caution; risk of explosive gases.

Batteries generate explosive gases during normal operation. Do not use near fuels, grain, dust, solvents, or other flammables; never smoke near the machine, battery, or charger.

Inspect battery and charger regularly.

Disconnect charger from wall outlet before operating. Machine should be off before connecting to a power source. Periodically inspect batteries, cables, charger, and all plug connections. Be extremely cautious when working with batteries. Do not open or tamper with batteries; doing so could cause electrical shock.

Charger Operation

Ensure proper use of charger.

- Once connected and plugged into AC power, the LED will indicate whether or not it is charging. Refer to manufacturer's charger manual.
- Only use charger on branch circuits protected by a circuit breaker or fuse that can carry the power of the charger.
- Do not use charger if it shows signs of physical stress, or if DC output leads or connector feel hot when used.
- Do not disconnect DC output clamps or connector from batteries while charger is on. This could cause an explosion.
- Failure to unplug AC power before moving equipment will damage cords, plugs, and receptacles.
- Do not over-discharge batteries, this could cause batteries to fail. Re-charge as soon as possible after discharge; if they are warm, first allow them to cool.
- Charger is not water proof, only resistant, and cannot withstand immersion, continuous exposure, or heavy rain.
- A drive lockout option will disable the drive mechanism of the machine while the charger is plugged in.
- There is a built-in Low Voltage Interrupter that continuously monitors for low voltage and will sound when voltage falls. At 44V the alarm will sound; stop immediately and recharge. At 43.5V the machine will auto-disconnect and shut down; let machine sit until batteries recover enough to drive to outlet.
- Chargers are equipped with a grounding plug.

Note: Leaving the charger plugged in does not harm the battery and is preferred to leaving the battery in a state of discharge.



WARNING: BE CAUTIOUS WHEN WORKING WITH BATTERY. IF ELECTROLYTIC ACID GETS IN THE EYES, IMMEDIATELY FLUSH OUT WITH COLD, FRESH WATER FOR AT LEAST 10 MINUTES AND GET MEDICAL HELP.



WARNING: ONLY USE BATTERY/CHARGER CONFIGURATIONS SPECIFICALLY APPROVED BY NFE. USE OF A DIFFERENT OR INCORRECT CONFIGURATION HAS A HIGH RISK OF LEADING TO FIRE, PREMATURE BATTERY FAILURE, DAMAGE TO MACHINE, AND/OR BODILY INJURY.



CAUTION: THE RETURN CAPACITY WHEN CHARGING THE BATTERY IS NOT 1-TO-1. ENSURE THAT BATTERY IS ALLOWED TO CHARGE FOR A GREATER PERIOD OF TIME THAN IT WAS USED (IF NOT COMPLETING A FULL CHARGE). FOR MAXIMUM BATTERY LIFE, FULLY RECHARGE BATTERY (LED WILL APPEAR SOLID GREEN) AT LEAST TWICE PER WEEK. FAILURE TO DO SO MAY RESULT IN SHORTER RUNTIMES AND PREMATURE BATTERY FAILURE.



WARNING: GRINDING/CUTTING/DRILLING OF MASONRY, CONCRETE, METAL AND OTHER MATERIALS CAN GENERATE DUST, MISTS AND FUMES CONTAINING CHEMICALS KNOWN TO CAUSE SERIOUS FATAL INJURY OR ILLNESS, SUCH AS RESPIRATORY DISEASE, CANCER, BIRTH DEFECTS OR OTHER REPRODUCTIVE HARM. IF YOU ARE UNFAMILIAR WITH THE RISKS ASSOCIATED WITH THE PARTICULAR MATERIAL BEING CUT, REVIEW THE MATERIAL SAFETY DATA SHEET AND/OR CONSULT YOU EMPLOYER, THE MATERIAL MANUFACTURER/SUPPLIER, GOVERNMENTAL AGENCIES SUCH AS OSHA AND NIOSH AND OTHER AUTHORITIES ON HAZARDOUS MATERIALS. CALIFORNIA AND SOME OTHER AUTHORITIES, FOR INSTANCE, HAVE PUBLISHED LISTS OF SUBSTANCES KNOWN TO CAUSE CANCER, REPRODUCTIVE TOXICITY, OR OTHER HARMFUL EFFECTS. CONTROL DUST, MIST AND FUMES AT THE SOURCE WHERE POSSIBLE. IN THIS REGARD USE GOOD WORK PRACTICES AND FOLLOW THE RECOMMENDATIONS OF THE MANUFACTURER/SUPPLIER, OSHA/NIOSH, AND OCCUPATIONAL AND TRADE ASSOCIATIONS. WHEN THE HAZARDS FROM INHALATION OF DUST, MISTS AND FUMES CANNOT BE ELIMINATED, THE OPERATOR AND ANY BYSTANDERS SHOULD ALWAYS WEAR A RESPIRATOR APPROVED BY OSHA/MSHA FOR THE MATERIAL BEING CUT.

HYDRAULIC SAFETY

Maintaining a Safe Work Environment

Establishing a safe work environment in and around your hydraulic equipment is extremely important. The easiest and most effective way to avoid problems is to make sure associates understand their equipment, know how to operate the machines safely, and recognize the dangers if handled carelessly. A few things to be aware of are:

- **Pressure:** Hydraulic fluid under pressure is dangerous and can cause serious injury. Never look for a leak when unit is under pressure. Using your hand could cause serious injury. A few common ways to encounter hydraulic fluid under pressure include:
 - Pinhole: Fluid under pressure can cause serious injury. It can be almost invisible escaping from a pinhole, and it can pierce the skin into the body.



DANGER: DO NOT TOUCH A PRESSURIZED HYDRAULIC HOSE ASSEMBLY WITH ANY PART OF THE BODY. IF FLUID PUNCTURES THE SKIN, EVEN IF NO PAIN IS FELT, A SERIOUS EMERGENCY EXISTS. OBTAIN MEDICAL ASSISTANCE IMMEDIATELY. FAILURE TO DO SO COULD RESULT IN LOSS OF THE INJURED BODY PART OR DEATH.

- Leak: Keep fittings and hoses tight. Only check and service when not under pressure. Leaking hydraulic fluid is hazardous; in addition to making workplace floors slippery and dangerous, it also contaminates the environment. Before cleaning an oil spill, always check EPA, state, and local regulations.
- Burst: Whether due to improper selection or damage, a ruptured hose can cause injury. If it bursts, a worker can be burned, cut, injected, or may slip and fall.
- Coupling Blow-Off: If the assembly is not properly made or installed, the coupling could come off and hit or spray a worker, possibly resulting in serious injury. Never operate machine without guards.
- **Flammability:** When ignited, some hydraulic fluids can cause fires and/or explode. With the exception of those comprised primarily of water, all hydraulic fluid is flammable (including many “fire-resistant” hydraulic fluids) when exposed to the proper conditions. Leaking pressurized hydraulic fluids may develop a mist or fine spray that can flash or explode upon contact with a source of ignition. These explosions can be very severe and could result in serious injury or death. Precautions should be taken to eliminate all ignition sources from contact with escaping fluids, sprays or mists resulting from hydraulic failures. Sources of ignition could be electrical discharges (sparks), open flames, extremely high temperatures, sparks caused by metal-to-metal contact, etc.



CAUTION: NEVER USE YOUR HANDS TO CHECK FOR LEAKS OVER HOSE OR HYDRAULIC CONNECTIONS. USE A PIECE OF CARDBOARD TO LOCATE A PRESSURIZED LEAK. FOR LOW PRESSURE LEAKS (DRIPS), USE A RAG TO CLEAN THE AREA AND DETERMINE WHERE THE LEAK ORIGINATES.

- **Mechanical:** Hydraulic fluid creates movement, which means some equipment may move. Observe surroundings and equipment at all times.
- **Moisture:** Do not use in wet or high moisture conditions.
- **Electrical:** Faulty wiring can be an electrical hazard. A regular preventive maintenance program should always include a wiring check. If applicable, disconnect battery before servicing.
- **Temperature:** Because this machine operates at a relatively low pressure, overheating is not common. If surface of tank becomes too hot to touch by hand (above 130°F or 55°C), shut off machine and allow it to cool.

Hydraulic Fluid

Only use Texaco Rando 46 Hydraulic Oil or compatible fluid like ISO or AW #46 from a brand name manufacturer. Non-compatible fluids could cause damage to unit or serious injury.

Maintenance Schedule

Maintenance to be performed	Interval					
	Daily	200 hrs	1000 hrs	2000 hrs	After initial 100 hrs	After initial 500 hrs
Inspect extension cord for damage	•					
Check wheels, caster and wheel motors for build up; and clean	•					
Inspect all safety devices (e-stop, backup beeper, seat switch)	•					
Inspects for leaks (hoses and fittings)	•					
Blow out fan cover on the bottom of the motor after each job	•					
Grease front caster wheel			•			
Check hydraulic oil level		•			•	
Replace the spin-on hydraulic oil filter		•			•	
Change hydraulic fluid			•			•

It is recommended to perform initial maintenance during the break-in period when first operating the machine. After the first 100 operating hours the hydraulic oil level should be checked and the spin-on hydraulic oil filter should be replaced, then every 200 hours thereafter. At the 500 operating hour mark the hydraulic fluid should be changed. Regular maintenance should be performed according to the schedule.



WARNING: THE BACK-UP BEEPER IS ON THE MACHINE FOR SAFETY. IT IS IMPORTANT TO KEEP IT IN GOOD WORKING CONDITION. FAILURE TO DO SO COULD CAUSE BODILY INJURY.

Troubleshooting Guide

Problem	Cause	Solution
Machine will not start.	Seat safety switch is disengaged.	Ensure operator is seated.
	Emergency stop (E-Stop) switch is disengaged.	Twist E-Stop into the "POWER ON" position.
	Circuit breaker is in the OFF position.	Verify circuit breaker is in "ON" position.
	48 volt blue plugs are not connected.	Make sure that connection plugs are fully installed.
	Wire harness is disconnected.	Connect wire harness.
	Batteries are low.	Charge batteries.
Machine doesn't run as long as it used to.	Battery is not fully charging.	Verify that you are charging machine properly. Verify that charger is working properly. Charger has a LED light to indicate.
	The 48 volt blue plugs are not connected.	Check that connection plugs are fully installed.
	Batteries no longer hold a charge.	Contact NFE customer service.
	Motor fan cover plugged with dust or debris.	Blow out fan cover after each job.
Machine is making rattling noises.	Loose hardware on machine.	Inspect and tighten bolts as needed.
Charger is hot.	Charger is in use.	This is normal.
Fluid is leaking from machine.	Hose connections/or fittings have loosened through normal use.	Tighten hydraulic hoses and fittings as needed.
	Pin hole in the hoses.	Replace affected hose.
	Oil and/or oil filter are old.	Replace oil and oil filter yearly on machine.
Tires/wheel motors make a slight clicking noise.		Normal noise with proper operation.
Machine is jerky or jumpy.	New operator.	Additional time is required to become familiar with machine.
	Control levers are being moved too quickly.	Operate control levers with wrists resting on knees or arm rests.
Coupling leaks at thread or seat.	Missing or damaged O-rings.	Check for missing or damaged O-rings; replace if necessary.
	Damaged threads due to misalignment or improper seat angle.	Correct seat angle. Check for thread damage; replace if necessary.
	Over or under torquing.	Only hand tighten hardware.
Any issues not listed above.		Please contact National to speak with a technician.

Maintenance



WARNING: ALWAYS DISCONNECT BATTERY BEFORE PERFORMING MAINTENANCE.

DUAL SLIDE PLATE REMOVAL



WARNING: ASSEMBLY IS VERY HEAVY. USE TEAM LIFT OR FORKLIFT TO LIFT. KEEP HANDS AND FEET OUT FROM UNDER THE ASSEMBLY. FAILURE TO DO SO COULD CAUSE SEVERE INJURY.

1. Lower the slide plate to the floor and place a wood block under the assembly.
2. Remove the front cylinder by taking the 1/2" bolt out of the bottom and removing the hitch clips and pin from the top of the cylinder.
3. Remove the E-clips from the pin at the bottom of the internal cylinder, then remove the pin.
4. Remove the pin from the top of the internal cylinder and then remove the cylinder from the machine.
5. Loosen the pinch bolt from the lower right side of the assembly.
6. Remove the lock nut from securing bolts at the top of the slide plate.
7. Remove the socket head screws at the top of the dual slide from both sides of the assembly.
8. Install 3/8-16x5" bolts into the holes the socket head screws were removed from. Once installed the bolts should be used as lifting handles.
9. Lift the assembly out of the machine.

LEAK MAINTENANCE

All fittings on this machine are O-ring style.

1. Disconnect machine from power.
2. If a leak is detected, tighten fitting with the proper wrench size. Do not over-tighten. Over-tightening could damage to O-rings.

CHECK HYDRAULIC OIL LEVEL

Check fluid level in the fill hole on the right side of the frame, in front of the rear wheel.

1. Remove filler plug. Oil should be visible 1" below hole.
2. Reinsert plug.

HYDRAULIC OIL CHANGE OUT

1. Disconnect machine from power (charger or battery).
2. Drain fluid by removing the drain plug from side of tank. This unit contains 6 gallons (22.7 liters) of fluid. Ensure the container size is adequate to catch fluid.
3. Replace drain plug.
4. Remove filler plug.
5. Add oil into the fill hole. Total tank capacity is 6 gallons (22.7 liters). Due to a certain amount of retained oil, the oil change refill amount is 5.5 gallons (20.8 liters). *NOTE: Adding more than this amount could cause the oil to overflow from the vent tube.*

CHANGE HYDRAULIC CYLINDER

1. Disconnect machine from power.
2. Disconnect cylinder lines. Have a container ready to catch oil from lines.
3. Remove cylinder securing hexhead bolt from lower cutting head support.
4. Remove clips and pin from cylinder and slide plate.
5. Remove cylinder upper pin.
6. Remove cylinder.

CHANGE/REMOVE HOSE

1. Disconnect machine from power.
2. Using proper wrench size, remove hose from fitting.
3. When replacing, make sure O-ring is properly seated on hose fitting.

CHANGE PUMP

1. Undo strap and bolts. Unplug (3) electrical connectors for charger and light.
2. Remove both rear hood and front hood cover.
3. Disconnect hydraulic lines.
4. Remove two 5/16" pump securing bolts.
5. Remove pump by pulling pump straight out from pump motor.

CHANGE VALVE

1. Disconnect machine from power (charger or battery).
2. Undo strap and bolts. Unplug (3) electrical connectors for charger and light.
3. Remove both rear hood and front hood cover.
4. Remove hoses from valve body. Have a container ready to catch leakage from lines.
5. Take notice of angle of valve fittings.
6. Remove three 5/16-18" bolts securing valve body.

CHANGE WHEEL MOTOR

1. Disconnect machine from power.
2. Block up machine to remove wheel.
3. Remove wheel.
4. Remove oil lines from wheel motor. A small amount of oil will run out of the lines. Drain into a container. Wipe up spills immediately.
5. Remove four 1/2" wheel motor securing nuts.
6. Pull out on wheel motor to remove.

Maintenance

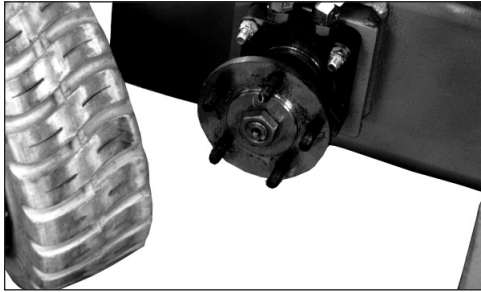

FIG. 1

CHANGE REAR WHEEL (FIG. 1)

1. Jack machine up by pushing the cylinder lift forward to lower and adjust the angle of the cutting head to raise machine.
2. Place blocks under forklift cups on the side of the machine that wheel is being changed.
3. Let cylinder down resting machine on blocks allowing rear wheel to be lifted off the floor.
4. Remove five 1/2" lug nuts with an extended arm wrench, remove wheel.
5. Replace wheel.
6. Replace five lug nuts and tighten, making sure lug nuts are very tight.
7. Raise cylinder to raise machine off of blocks. Remove blocks and lower machine.
8. Repeat to other side if necessary. caster wheel maintenance

CHANGE CASTER

Keep clean and free of debris; ensure it can move freely.

1. Give a shot of grease in grease fitting on caster every month to keep caster moving freely.
2. To remove caster, machine will need to be raised. Push the cylinder lift lever forward to lower and adjust the angle of the cutting head to jack up the machine. Block up machine with wooden block. Remove four bolts, pull caster off and clean/replace as needed.
3. Replace caster.
4. Pull caster toward rear of machine; re-place and tighten the four bolts.
5. Lower the machine.

CHANGE MOTOR

1. Disconnect motor from power.
2. Undo strap and bolts. Unplug (3) electrical connectors for charger and light.
3. Remove both rear hood and front hood cover.
4. Remove pump.
5. Loosen screws and nuts.
6. Raise motor; disconnect electrical connections.
7. Remove and replace motor.
8. Reverse steps for installation.

SEAT REPLACEMENT

1. Undo strap and bolts. Unplug (3) electrical connectors for charger and light.
2. Remove both rear hood and front hood cover.
3. Remove four nuts securing seat rails. Replace seat; screw on nuts.

REMOVE/REPLACE FOOT PEG

1. Insert a socket wrench into foot peg and secure bolt head.
2. Remove nut.
3. Remove bolt and foot peg.
4. Replace foot peg before operating machine. Do not operate machine without foot pegs.

CLEAN WHEEL MOTOR BUILD-UP

1. Inspect the wheel motor and wheel motor hub for debris build-up (best accessed from back of machine). Remove any strands of carpet and use compressed air (not high pressure) to clean out dust or glue build-up. If any build-up cannot be removed this way, complete the following steps to remove the wheel hub.
2. Raise the front of the machine up by lowering the front cutting head down all the way, or by using 2 ton jack. Place blocks under the fork lift cup.
3. Slowly raise the cutting head until the machine is resting on the blocks and the wheel on the side that is blocked up is raised off the ground.
4. Remove the cotter pin and loosen the center wheel hub nut.
5. To loosen the wheel from the wheel motor shaft you might need to hit the steel rim from the inside with a rubber mallet.
6. Remove the wheel and remove the build up off of the wheel motor shaft.
7. Re-mount the wheel hub, making sure that the keyway matches on the motor shaft. Tighten down the wheel hub nut to press fit in the wheel hub.
8. Re-insert the cotter pin.
9. Lower the cutting head to raise the machine back off the blocks.
10. Repeat the process for the opposite side if needed.

Parts List and Diagrams

EXTERNAL

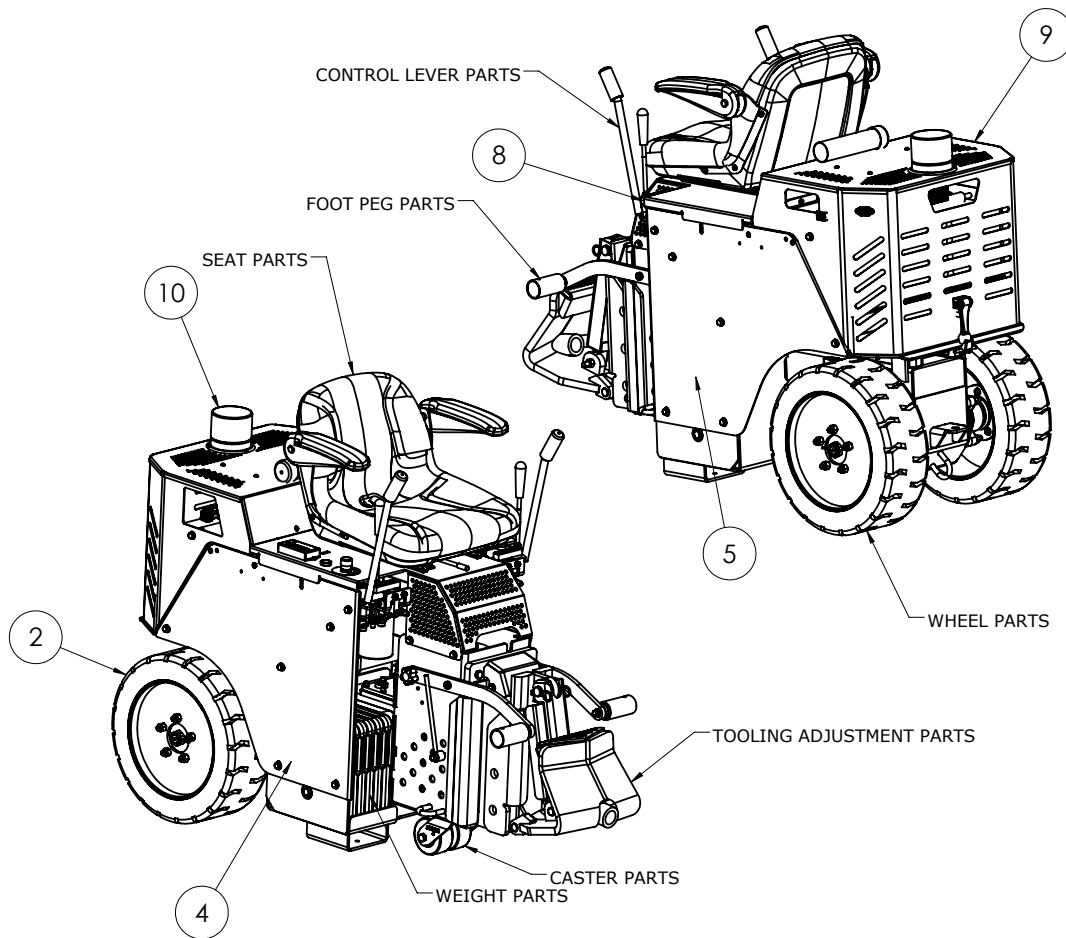

ITEM NO.	5000-17XXXX	5000-11XXXX 5000-20XXXX	5000-15XXXX	DESCRIPTION	QTY.
1*	400177	400177	400177	Oil (Bulk)	6
2	5110-405	5110-405	5110-405	Wheel, Rim & Tire 18"	2
3*	5200QL-27	5200QL-27	5200QL-27	Base, Main	1
4	5200QL-25-SV	5200QL-25-SV		Panel, Right, Silver Vein	1
			5200QL-25-O	Panel, Right, Orange	
5	5200QL-26-SV	5200QL-26-SV		Panel, Left, Silver Vein	1
			5200QL-26-O	Panel, Left, Orange	
6*	2900-101	2900-101	2900-101	Hold Down, Rear	1
7*	403198	403198	403198	Assembly, Box, Electrical, 2900	1
8	402995-SV	402995-SV		Hood, Front, Raised w/ Doghouse, Silver Vein	1
			402995-O	Hood, Raised, Front w/ Doghouse, Orange	
9	402996-SV	402996-SV		Hood, Rear, Vented, Silver Vein	1
			402996-O	Hood, Rear, Vented, Orange	
10		70629	70629	Light, Flashing	1

*NOT SHOWN

Parts List and Diagrams

REAR WHEEL ASSEMBLY

ITEM NO.	PART NUMBER	DESCRIPTION	QTY.
1	400133	Motor, Wheel, Hydraulic, 10mm	1
2	73047	Key, Woodruff 5/16 x 1	1
3	73402	Nut, Nylock 1/2-13	4
4	5110-117	Wheel, Hub	1
5	73430	Nut, NyLock 1/2-20	5
6	5110-405	Wheel, Rim and Tire, 18"	1
7	5110-117-2	Hub Nut	1
8	401433	Pin, Cotter 1/8 x 1.75	1

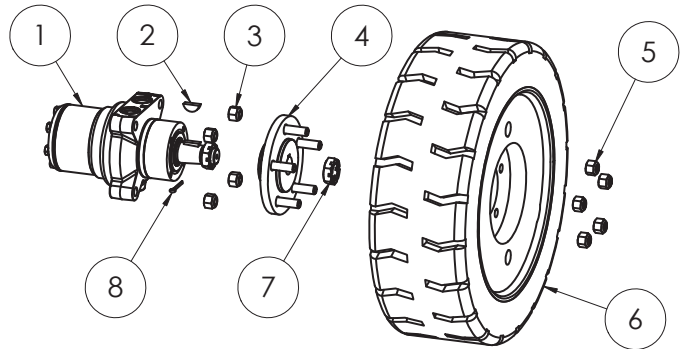

CASTER WHEEL ASSEMBLY

Item No.	Part No.	Description	Qty.
1	402280	Caster Assy, Kingpinless, 4", Plate-Mount	1
1.1*	403352	Wheel, 4"OD x 2-1/2"W (Wheel Only)	1
1.2*	403353	Axle, Including Nut	1
2	73403	Washer, Lock, 1/2	4
3	73406	Screw, Hex Head Cap, 1/2-13x1-1/4	4
4	73424	Washer, Flat, Zinc SAE 1/2	4

*Items 1.1 and 1.2 are included as part of Item 1 and are also available individually.

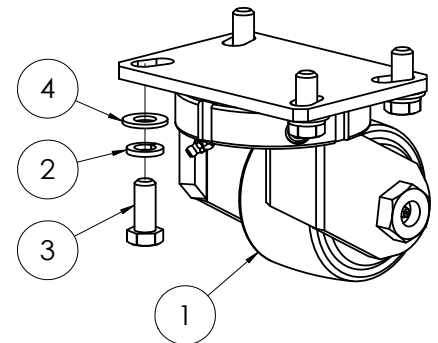

WEIGHTS

ITEM NO.	PART NUMBER	DESCRIPTION	QTY.
1	73424	Washer, Flat, Zinc SAE 1/2	6
2	73403	Washer, Split lock 1/2	6
3	5110-404	Bottom Weight	1
4	73427	Bolt, Hex Head Cap 1/2-13x1-1/2	1
5	74854	Weight, Pocket, Cast, Ride On	10
6	73531	Washer, Flat Zinc, SAE 5/8	2
7	73414	Bolt, HHCS, 1/2-13x7	2

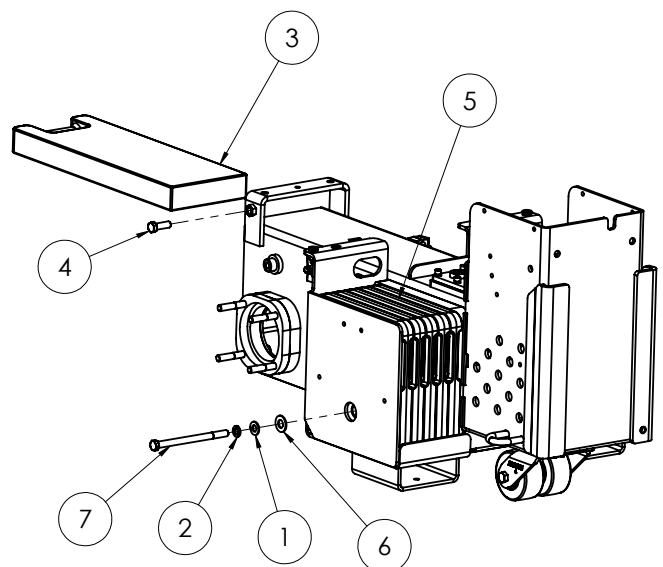

Parts List and Diagrams

SEAT ASSEMBLY

PART#	DESCRIPTION	QTY
1 5110-111	SEAT, RIDE-ON	1
2 400321	ARM RESTS, KIT FOR SEAT	1
3 402969	BOLT, TRILOBULAR, 5/16-18 X 1.25, FLANGED HEX HEAD (NOT SHOWN)	4
4 5110-207	SWITCH, SEAT	1
5 403137	HARNESS, SEAT, 2900 (NOT SHOWN)	1



FOOT PEGS

ITEM NO.	PART NUMBER	DESCRIPTION	QTY.
1	402298	Bracket, Pivot, Footrest	1
2	73207	NUT, NYLOCK, 3/8-16	2
3	401999	Knob, Adjustable, 3/4"	1
4	5110-180	Peg, Foot	1
5	402460	Bolt, Shoulder, .500 x .75, 3/8-16	1
6	73263	WASHER, FLAT SAE ZINC 3/8	1
7	73238	Bolt, Flange 3/8-16x1-1/2	1

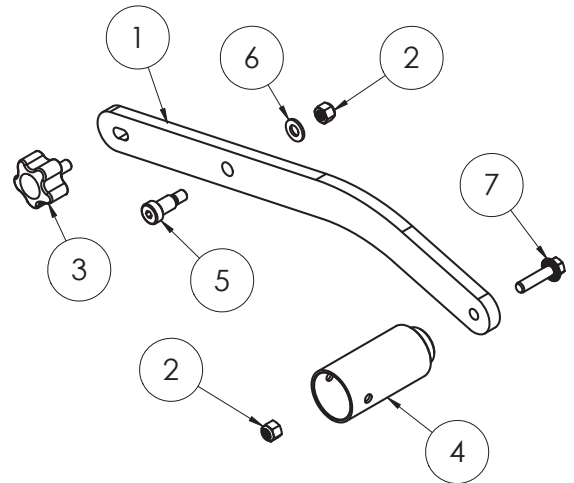

INSTRUCTION TUBE

PART#	DESCRIPTION	QTY
1 70602	TUBE, INSTRUCTION MANUAL	1
2 70603	CAP, INSTRUCTION TUBE	1
3 74425	NUT, KEPS LOCK 10-32	2

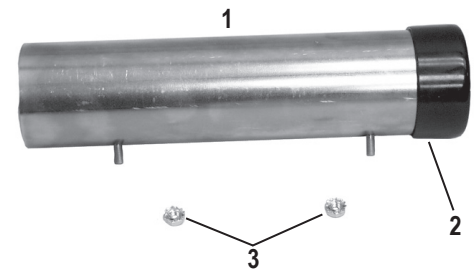

FRONT WHEEL ASSEMBLY

PART#	DESCRIPTION	QTY
1 5110-100	TRANSPORT WHEELS	1
2 5110-100W	CASTER ASSY, 5", TRANSPORT WHEEL	2



Parts List and Diagrams

BREATHER DIP STICK

PART#	DESCRIPTION	QTY
1 405291	BREATHER CAP, WITH SPLASH GUARD, 1/4 NPT	1
2 402989	PIPE, RELIEF VALVE, 2-1/2"	1
3 5110-234	COUPLER, RELIEF VALVE	1
4 70655	PIPE, MALE, 10" X 3/4"	1

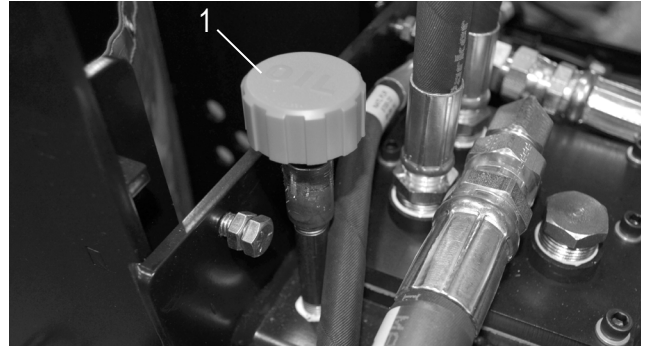

HOSE CLAMP ASSEMBLY

PART#	DESCRIPTION	QTY
1 5200-261-1A	CLAMP	2
2 5200-261-1B	BODY ONLY, CLAMP	4
3 73063	BOLT, HEX HEAD CAP 1/4-20X1-3/4	2
4 73002	WASHER, SPLIT LOCK 1/4	2

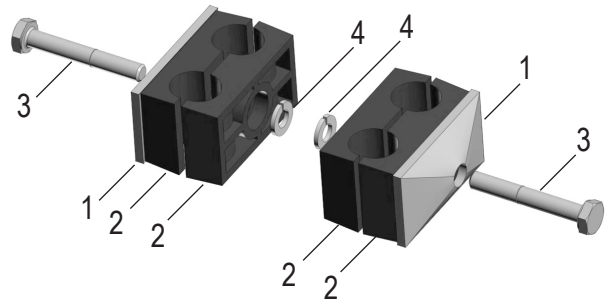

SPOOL AND HOSE

PART#	DESCRIPTION	QTY
1 5200-261	HOSE, WHEEL MOTOR	4
2 5700-72	HOSE, HYDRAULIC, 3/8 X 26, F/F	2
3 5700-76	HOSE, HYDRAULIC, 3/8 X 21, F/F	2
4	SEE CONTROL LEVER (DUAL LIFT) PARTS	
5 70351	HOSE, HYDRAULIC, 3/8 X 10, F/90F (NOT SHOWN)	1
6	SEE GEAR PUMP ASSEMBLY	
7 5110-114-2	WHEEL MOTOR FITTING	4
8 5700-70	T-FITTING (NOT SHOWN)	1
9 5700-77	SUCTION HOSE ASSEMBLY (NOT SHOWN)	1
10 5700-81	SUCTION LINE (NOT SHOWN)	1
11 5110-157	PLUG, DRAIN-FILLER (NOT SHOWN)	2
12 6280-162G	MAGNET, TANK (NOT SHOWN)	2
13 401635	HOSE, HYDRAULIC, 3/4 X 29, F/90F (NOT SHOWN)	1

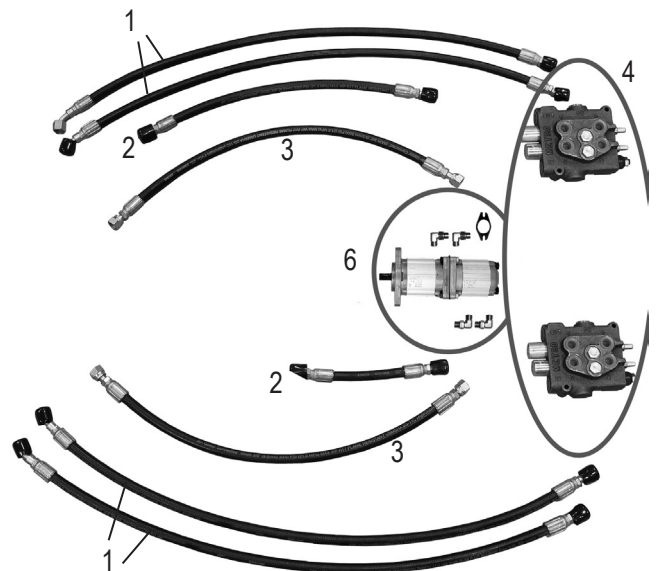

Parts List and Diagrams

SUCTION ASSEMBLY & FILTER

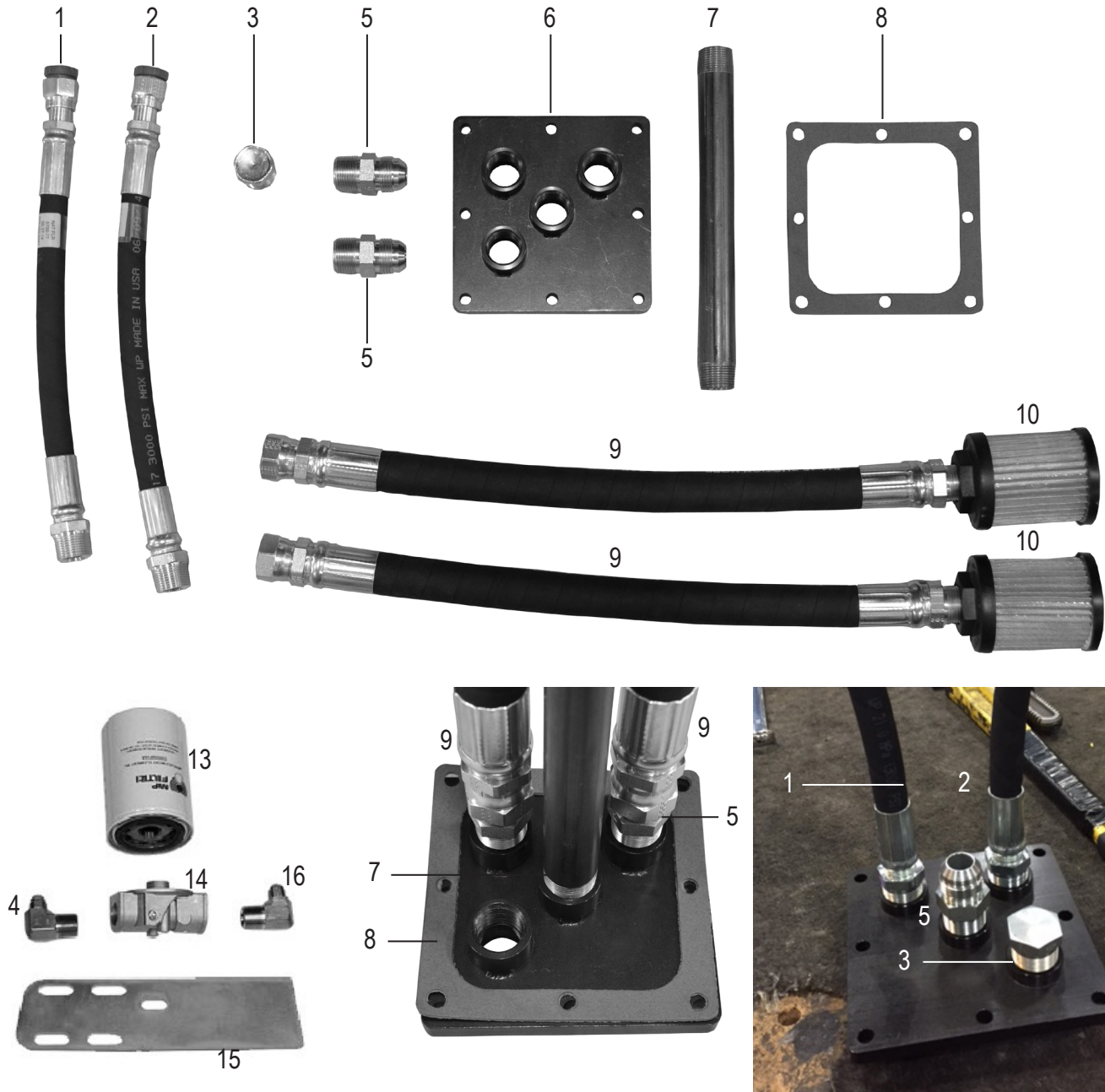

PART#	DESCRIPTION	QTY	PART#	DESCRIPTION	QTY
1	5700-77 ASSEMBLY, HOSE	1	10	5110-237 FILTER, SCREEN	2
2	5700-81 HOSE, SUCTION LINE	1	11	73310 SCREW, SHC, 5/16-18 X 7/8	8
3	5700-67 PLUG, TANK	1	12	73303 WASHER, SPLIT LOCK, 5/16	8
4	70653 FITTING, 90 DEGREE	1	13	5700-65 FILTER	1
5	70652 FITTING	3	14	5700-66 HEAD	1
6	401574 PLATE, SUCTION	1	15	70612 BRACKET	1
7	70655 PIPE, MALE, 10" X 3/4	1	16	5700-64 FITTING, FILTER	1
8	5700-93 GASKET	1			
9	400099 HOSE, SUCTION, 1/2" X 20" W/ FITTING	2			

Parts List and Diagrams

GEAR PUMP ASSEMBLY

PART#	DESCRIPTION	QTY
1	70905-D5 PUMP, DOUBLE, MARZOCCHI	1
2	5200-1G GASKET, PUMP	1
3	72816 FITTING, ELBOW, 90 DEGREE, 3/8"	2
4	6280-118 FITTING, SUCTION HOSE TO PUMP	2
5	73263 WASHER, FLAT SEA ZINC 3/8	2
6	73204 WASHER, SPLIT LOCK 3/8	2
7	403626 SCREW, FERRY CAP, 3/8-16 X 3/4", 12PT	2

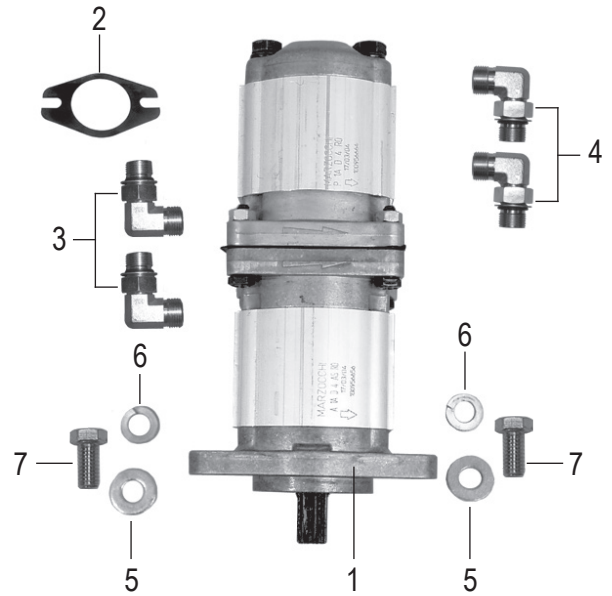

MOTOR

PART#	DESCRIPTION	QTY
1	72385 4 HP MOTOR	1
2	5200QL-1A MOTOR PLATE	1
3	73242 SCREW, BUTTON HEAD CAP WITH FLANGE 3/8-16 X 1	4
4	73210 WASHER, INTERNAL/EXTERNAL LOCK 3/8 4	4
5	73207 NUT, NYLOCK 3/8-16 (NOT SHOWN)	4

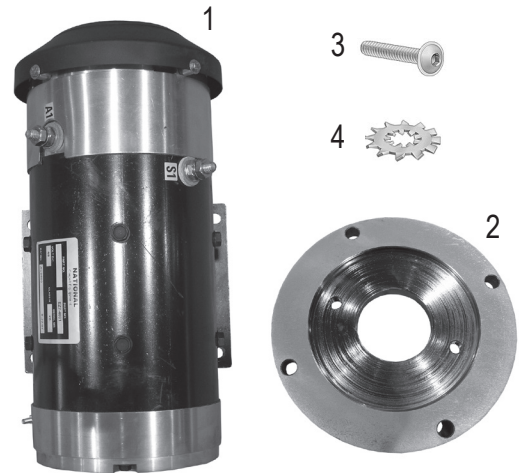

Parts List and Diagrams

CONTROL LEVER (DUAL LIFT)

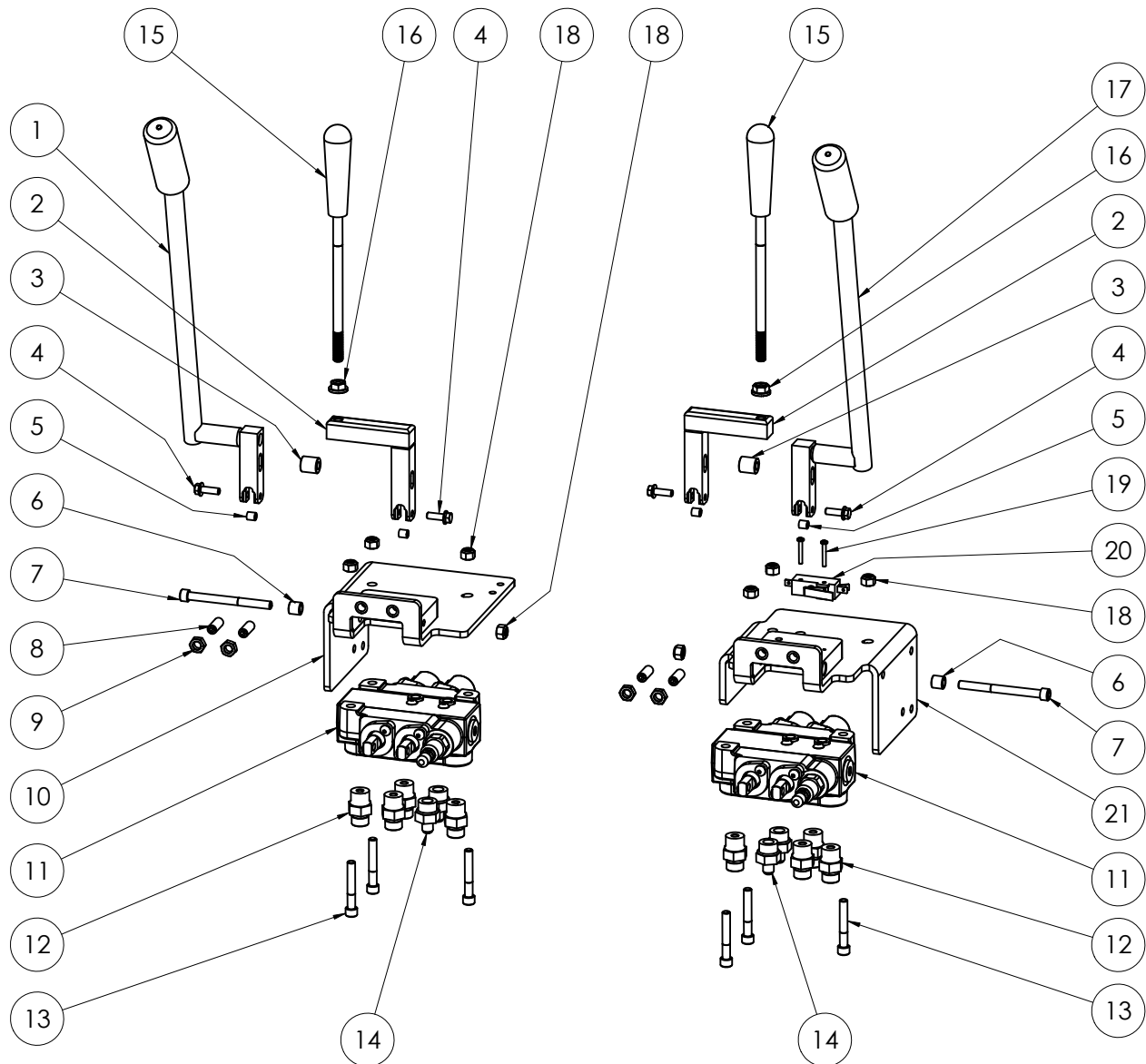

ITEM NO.	PART NUMBER	DESCRIPTION	QTY.	ITEM NO.	PART NUMBER	DESCRIPTION	QTY.
1	402416	Assembly, Valve Handle, Right	1	12	400034	Fitting, FF1231-06-08	8
2	401797	Bracket, Universal, Lever	2	13	73320	Bolt, Socket Head Cap 5/16-18x2	6
3	401408	Spacer, Round, .323 X .625 X .675	2	14	400137	Fitting, 1/2 - 1/4, JIC	4
4	73027	Bolt, Wizlock, 1/4-20 X 3/4	4	15	5700-60	Handle, Valve Adjustment	2
5	401604	Bushing, Lever, Hydro Valve	4	16	73211	Nut, Flange, Serrated, 3/8-16	2
6	402227	Sleeve, Take-up, Valve Brkt	2	17	402415	Assembly, Valve Handle, Left	1
7	73321	Bolt, SHCS, 5/16-18x3.5	2	18	73322	Nut, Nyloc, 5/16-18	8
8	73227	Screw, Set 3/8-24x1	4	19	74517	Screw, PPH-MS, 6-32x1	2
9	73235	Nut, Hex Jam 3/8-24	4	20	5110-218	Switch, Back-up Beeper	1
10	401796	Bracket Wldt, Valve, RH	1	21	401795	Bracket Wldt, Valve, LH	1
11	401832	Valve, Metered, Dual Spool, Low PSI	2				

Parts List and Diagrams

DUAL SLIDE PLATE

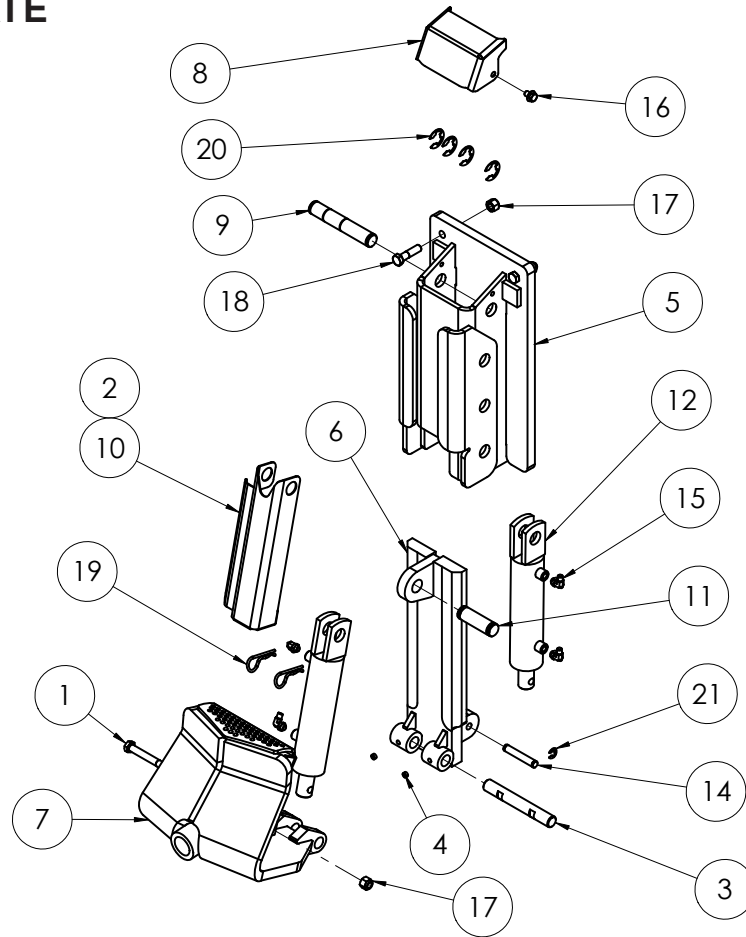

ITEM NO.	PART NO.	DESCRIPTION	QTY.
1	400132	Bolt, Hex Head, 1/2-13 x 4, Grade 8	1
2*	400296	Gasket, EPDM Foam	1
3	401429	Pin, Lower Cutting Head Support	1
4	401876	SSS, 3/8-24 x .25, Black Oxide	2
5	402423	Housing, Hydraulic Adjustment, Wldt	1
6	402432	Slide Plate, Hydraulic Adjustment, Wldt	1
7	402440	Tooling Holder, Weldment	1
8	402513	Cover, Hydraulic Adjustment, Housing	1
9	402542	Pin, Upper, Hydraulic Cylinder	1
10	402574	Shield, Cylinder	1
11	402576	Pin, Cylinder/Guard, Upper	1
12	5110-250	Cylinder NN16	2
13*	5110-267	Hose, Assembly, Hydraulic, 1/8 x 31.75, F/F	2
14	6500-31	Pin Lower Middle	1
15	72801	Fitting, 90 Deg., 1/4"	4
16	73224	Bolt, Wizlock, 3/8-16x1/2	2
17	73402	Nut, Nylock, 1/2-13	3
18	73413	Bolt, Hex Head 1/2-13x2	2
19	73536	5/8 Hitch Pin Clip	2
20	80083	E-Clip, 1" shaft	4
21	80084	E-Clip, 1/2" shaft	2

*Not shown

Parts List and Diagrams

ELECTRIC BOX & BATTERY CONNECTOR

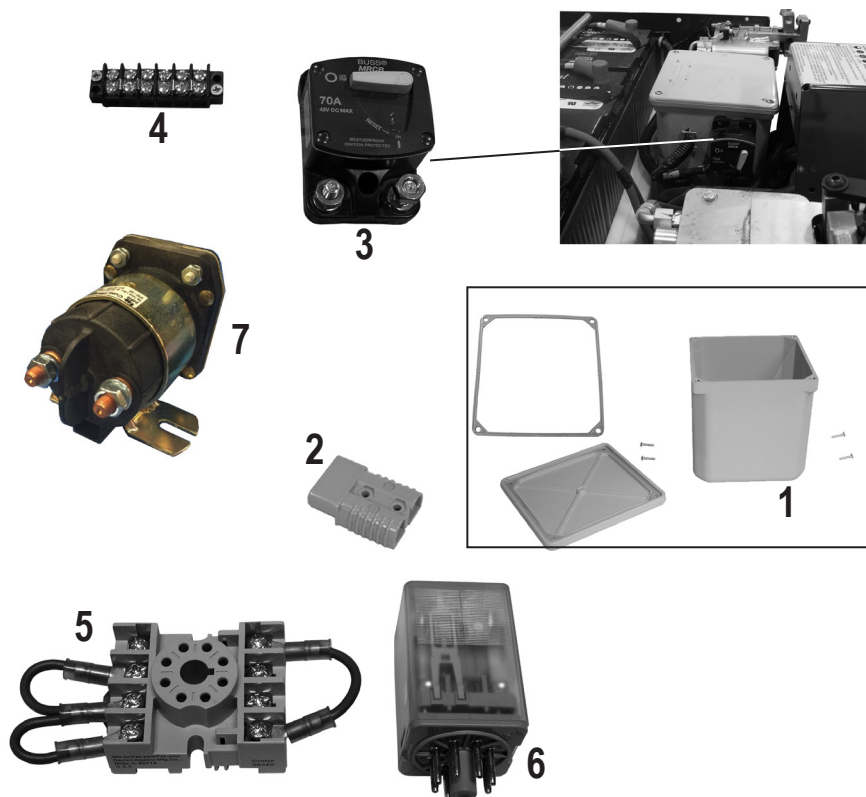

PART#	DESCRIPTION	QTY	PART#	DESCRIPTION	QTY
1	5200-118-1A BOX, ELECTRICAL, ONLY	1	5	5700-90 RELAY, SOCKET	1
2	5200-118-9 CONTACTS, TERMINAL, SB175 SERIES	2	6	5700-91 RELAY	1
3	5700-106 BREAKER, CIRCUIT, 70 AMP	1	7	5700-104 SOLENOID	1
4	5200-127 TERMINAL, STRIP	1			

PARTS NOT SHOWN

PART#	DESCRIPTION	QTY	PART#	DESCRIPTION	QTY
1	400206 WIRE, PRIMARY, 16 GPT-500-BLK	1	15	74761 GROMMET, RUBBER 3/8"	1
2	400207 WIRE, PRIMARY, 16 GA, RED, GPT SERIES	1	16	402886 PROBE, THERMAL	1
3	5700-88 METER, HOUR	1	17	403245 SEAL, CABLE, 16 GA, METRI-PACK 150	12
4	70610 LOOM, CORROGATED, SLIT, BLACK, .250 ID	6	18	403246 TERMINAL, FEMALE, 18-16 GA, METRI-PACK 150	12
5	71703 PROTECTOR, BATTERY TERMINAL, RED	2	19	403247 LOCK, FEMALE, 4 POSITION, METRI-PACK 150	1
6	72580 WIRE, PRIMARY, 16 GPT-500-BLU (TSC)	4.3	20	403248 LOCK, FEMALE, 8 POSITION, METRI-PACK 150	1
7	72581 WIRE, STRANDED, 16 GAUGE, WR16-9	4.3	21	403249 CONNECTOR, FEMALE, 8 POSITION, METRI-PACK 150	1
8	72761 TERMINAL, END, BATTERY 4	4	22	403250 CONNECTOR, FEMALE, 4 POSITION, METRI-PACK 150	1
9	72765 TERMINAL, END, NYLON, 12-10	2	23	403256 TERMINAL, RING, 16-14 GA, 3/8" STUD, NYLON INSULATED	2
10	72778 TERMINAL, 16-14 GAUGE, NYLON, B RING	20	24	400254 WIRE, PRIMARY, 16 GPT-500-YEL	30
11	72815 TERMINAL CONNECTOR, FEMALE, PUSH-ON	2			
12	72821 TERMINAL, RING, 16-14 GAUGE, NYLON, 10 STUD	8			
13	72835 HOUSING, CONTACT, BLUE	1			
14	73504 STRAIN RELIEF, STRAIGHT 3/4 INCH .750"-1.00	3			

Parts List and Diagrams

POWER CONTROLS (DOMESTIC)

PART#	DESCRIPTION	QTY
1	5700-103 SWITCH, START, ASSEMBLY	1
	72451* CONTACT BLOCK, NO, 10A, SPRING	
	CLAMP, ZB4 SERIES	1
	72454 SWITCH, START	1
	72456* COLLAR, MOUNTING, 22MM, ZB4 SERIES	1
2	5700-102 ASSEMBLY, E-STOP	1
	72452* CONTACT BLOCK, NC, 10A, SPRING	
	CLAMP, ZB4 SERIES	2
	72453 SWITCH, 22MM, E-STOP, ZB4 SERIES	1
	72456* COLLAR, MOUNTING, 22MM, ZB4 SERIES	1
	5700-102D LABEL, EMERGENCY STOP	1
3	403042 ALARM, LOW VOLTAGE	1
4	74567 SCREW, PHILLIPS PAN HEAD, 8-32X3/8, ZINC-PLATED	2

*NOT SHOWN



POWER CONTROLS (INTERNATIONAL)

PART#	DESCRIPTION	QTY
1	401415 ASSEMBLY, KEYED SWITCH	1
	72451* CONTACT BLOCK, NO, 10A, SPRING	
	CLAMP, ZB4 SERIES	1
	72455 SWITCH, KEYED	1
	72456* COLLAR, MOUNTING, 22MM, ZB4 SERIES	1
2	5700-102 ASSEMBLY, E-STOP	1
	72452* CONTACT BLOCK, NC, 10A, SPRING	
	CLAMP, ZB4 SERIES	2
	72453 SWITCH, 22MM, E-STOP, ZB4 SERIES	1
	72456* COLLAR, MOUNTING, 22MM, ZB4 SERIES	1
	5700-102D LABEL, EMERGENCY STOP	1
3	403042 ALARM, LOW VOLTAGE	1
4	74567 SCREW, PHILLIPS PAN HEAD, 8-32X3/8, ZINC-PLATED	2

*NOT SHOWN

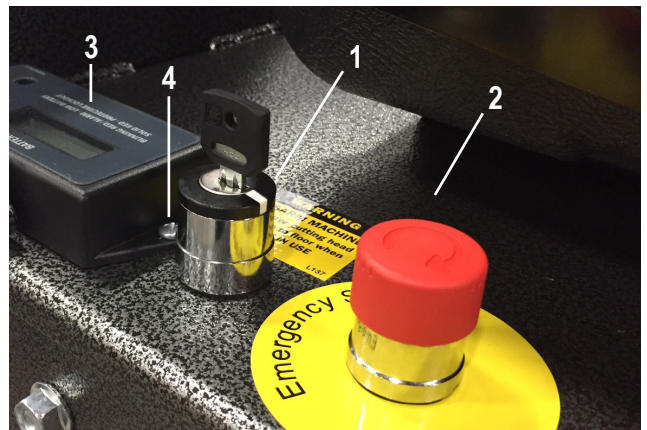

Parts List and Diagrams

BATTERIES

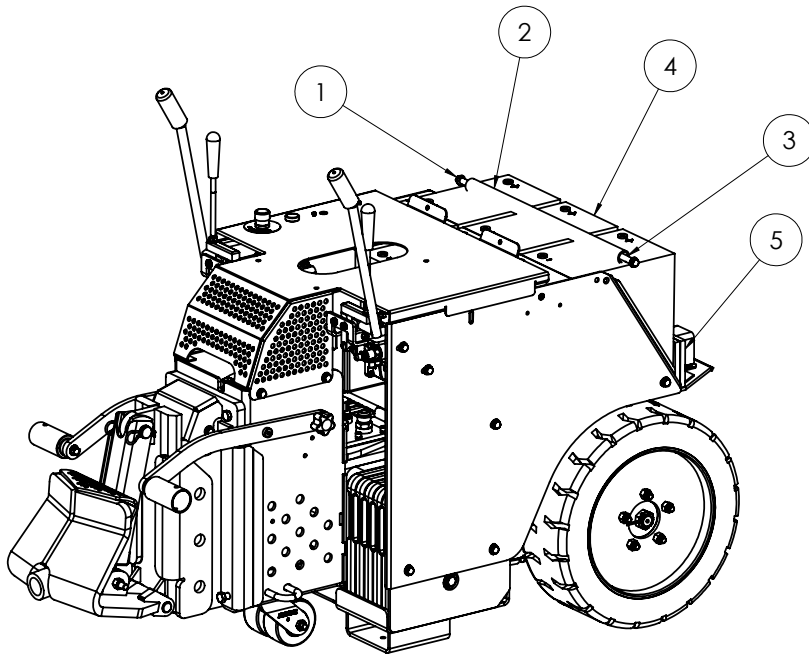

ITEM NO.	PART NUMBER	DESCRIPTION	QTY.
1	73224	Bolt, Flange 3/8-16x1/2	2
2	5700-62	Cover, Battery Hold Down	2
3	401674	Rod, Hold-down, Battery	1
4	5213-3	Battery, 200 Amp, 8V	6
5	5700-56	Spacer, Battery	8

* 402996 HIDDEN FOR CLARITY

LINE FILTER (INTERNATIONAL ONLY)

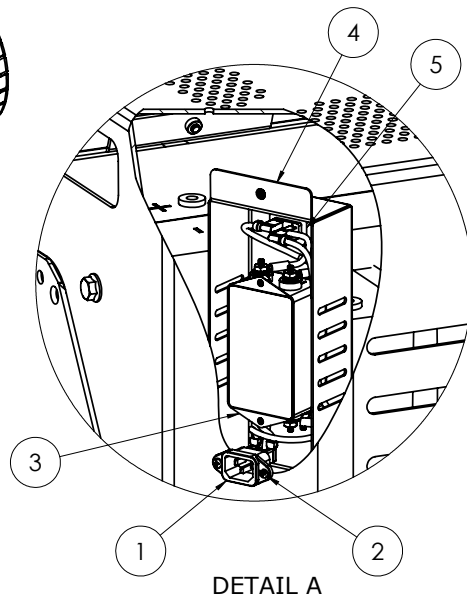
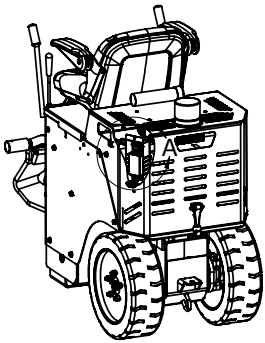

ITEM NO.	PART NUMBER	DESCRIPTION	QTY.
1	403195	Plug, IEC 320-C13 Panel Mount, Flanged	1
2	74508	Screw, Phillips Pan Head Machine 6-32x1/2	2
3	403766	Filter, Line, 250VAC, 20A	1
4	403770	Cover, Line Filter	1
5	403176	Receptacle, Panel Mount, IEC C-13, 250V, 15A	1

Parts List and Diagrams

CHARGER ASSEMBLY

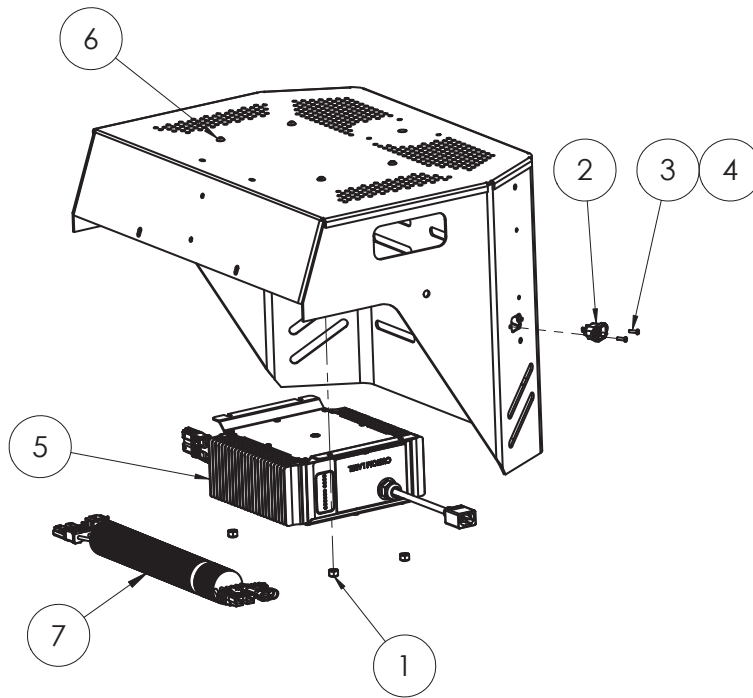

ITEM NO.	5000-17XXXX	5000-11XXXX 5000-15XXXX	5000-20XXXX	DESCRIPTION	QTY.
1	73322	73322	73322	Nut, Hex, Nylon Insert, 5/16-18	4
2		403195	403195	Inlet, IEC C14, Flanged, 250V, 15A	1
3		74508	74508	Screw, Phillips Pan Head, 6-32x1/2	2
4		74518	74518	Nut, Keps, 6-32	2
5	406470	406470		Assembly, Charger, Battery, 1500W, 108-250VAC, Hi-Freq, 160-200AH	1
			406471	Assembly, Charger, Battery, 1000W, 85-265VAC, Hi-Freq, 160-220AH	1
6	73003	73003	73003	Screw, Button Head Socket Cap, 1/4-20x5/8	4
7	403146	403146	403146	Harness, Charger	1
8*	402878			Cord, Power, SJTO, 14/3, NEMA 5-15 TO C-13, 2ft	1

*Not shown

Parts List and Diagrams

BACKUP BEEPER ASSEMBLY

	PART#	DESCRIPTION	QTY
1	5200-116	BACK-UP BEEPER ASSEMBLY	1
2	73020	BOLT, WIZLOCK 1/4-20X5/8	2



HEADLIGHT ASSEMBLY

ITEM NO.	PART NUMBER	DESCRIPTION	QTY
1	403976	Switch, Rocker, SP, 14V, 16 A	1
2	404009	Shroud, Worklight, Rider, Low Profile	1
3	404041	Light, Work, 6"x2", Flush, 18W	1
4	404060	Screw, Button Head Cap, M5x0.8x10, Black Oxide	2
5	74631	Bolt, Wizlock, M6-16	4

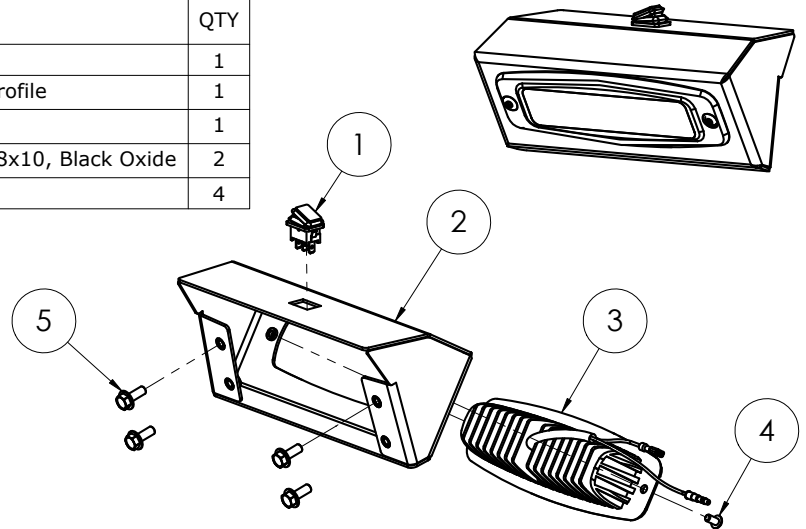

Parts List and Diagrams

LABELS

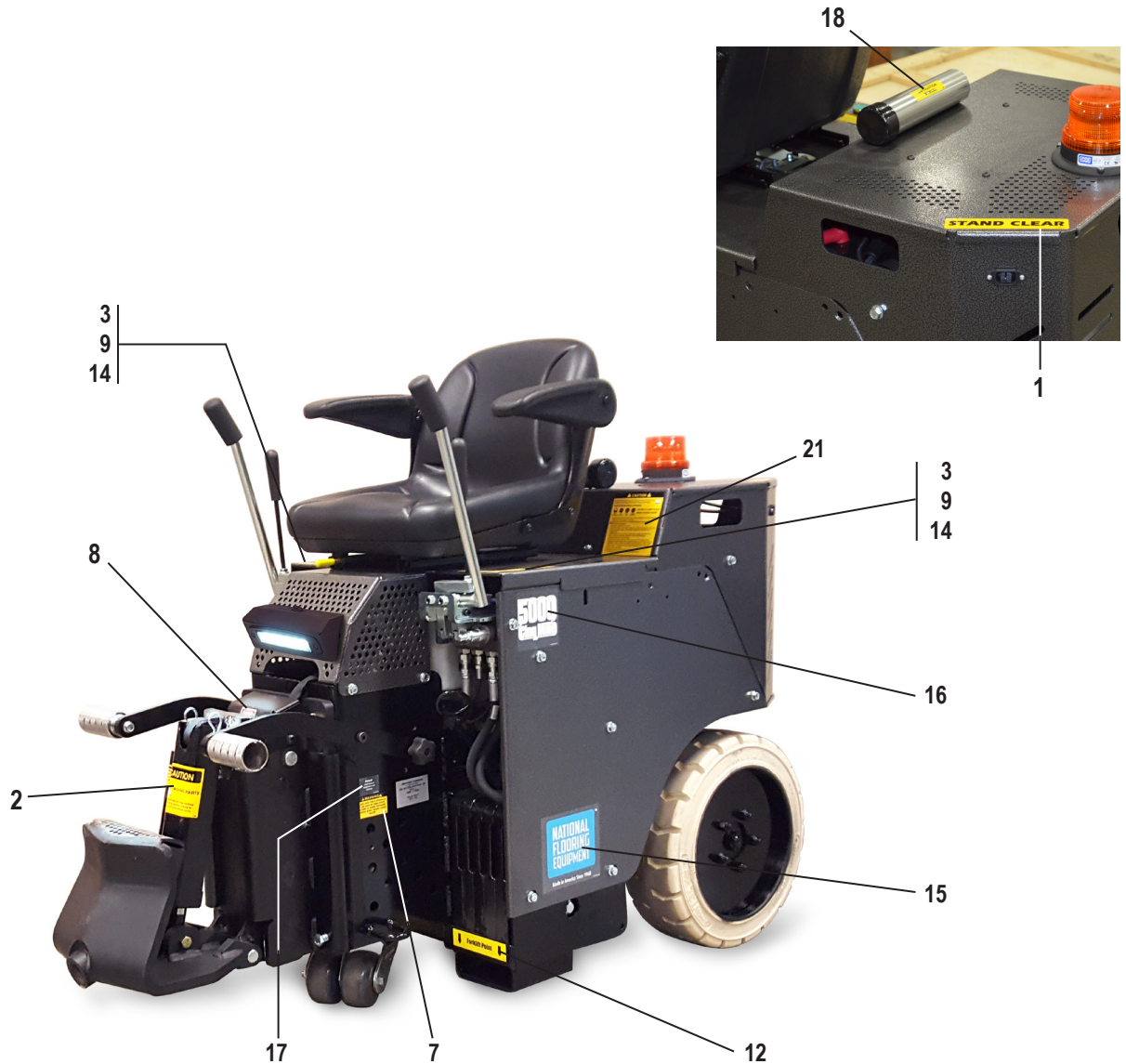

PART#	DESCRIPTION	QTY	PART#	DESCRIPTION	QTY
1	L08-1	2	15	402464	2
2	L33B	1	16	403287	2
3	L137	3		405296	2
4	L309*	6	17	L223	1
5	L311-2*	6	18	L33C	1
6	L66*	1	19	403783*	1
7	L95F	2	20	404298*	1
8	L106	2	21	L155	1
9	L118	2	22	L305*	1
10	L142*	1	23	402926*	1
11	402376*	1		402927*	1
12	402149	2			
13	L38*	1			
14	L98	2			

*NOT SHOWN

Wiring Diagrams

MAIN WIRING DIAGRAM

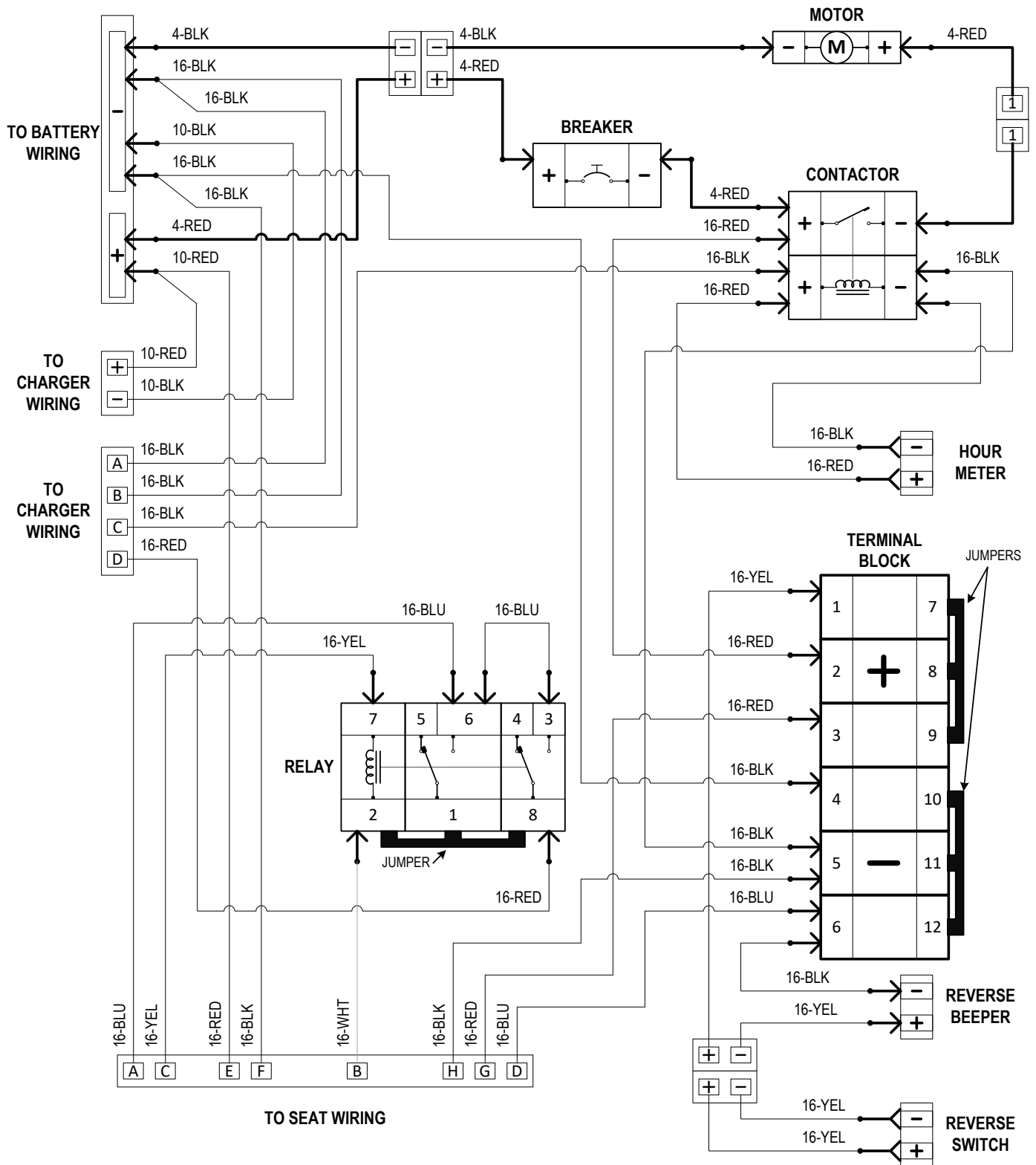

Wiring Diagrams

SEAT WIRING DIAGRAM

TO BODY WIRING

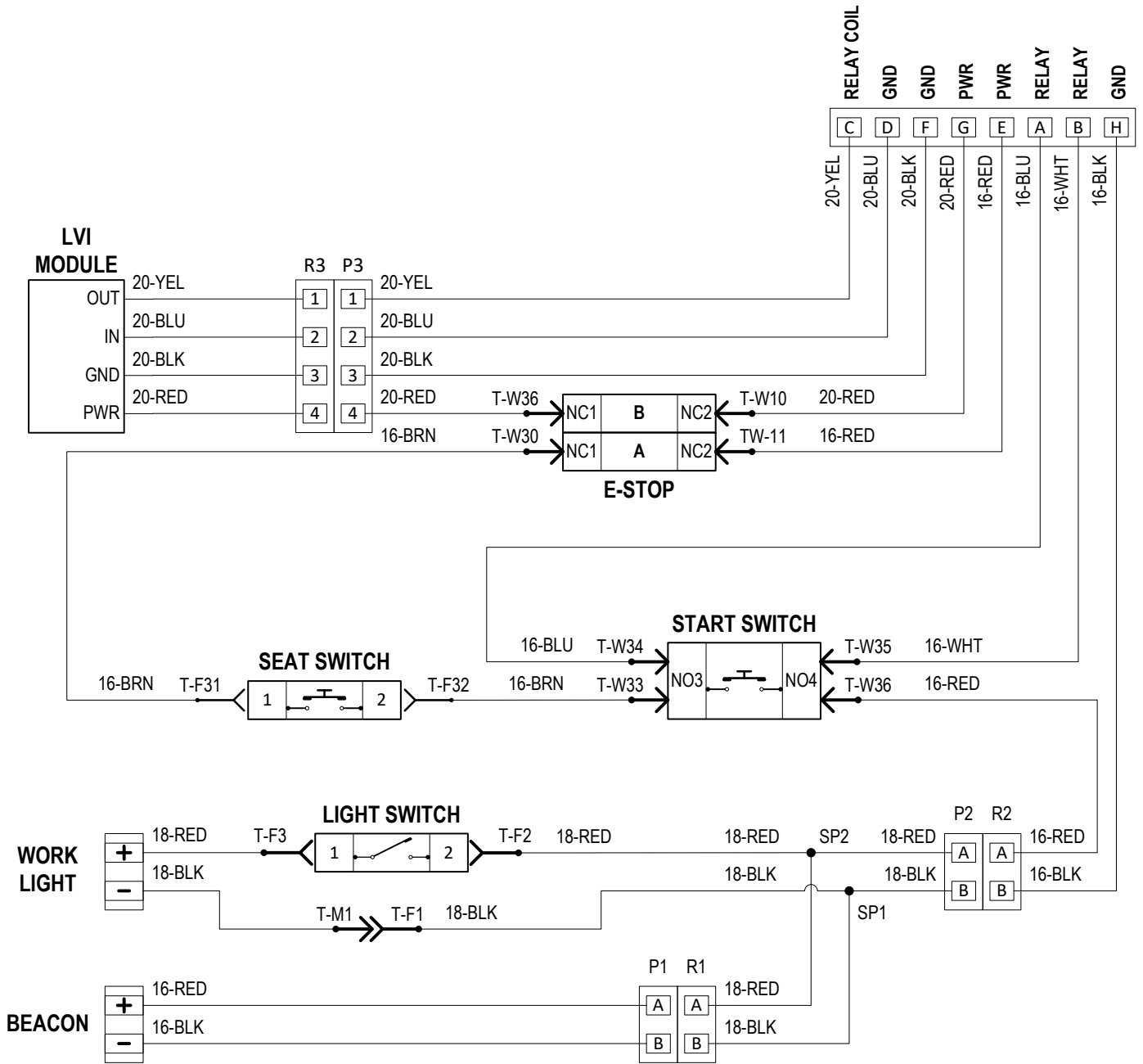

Wiring Diagrams

CHARGER WIRING DIAGRAM

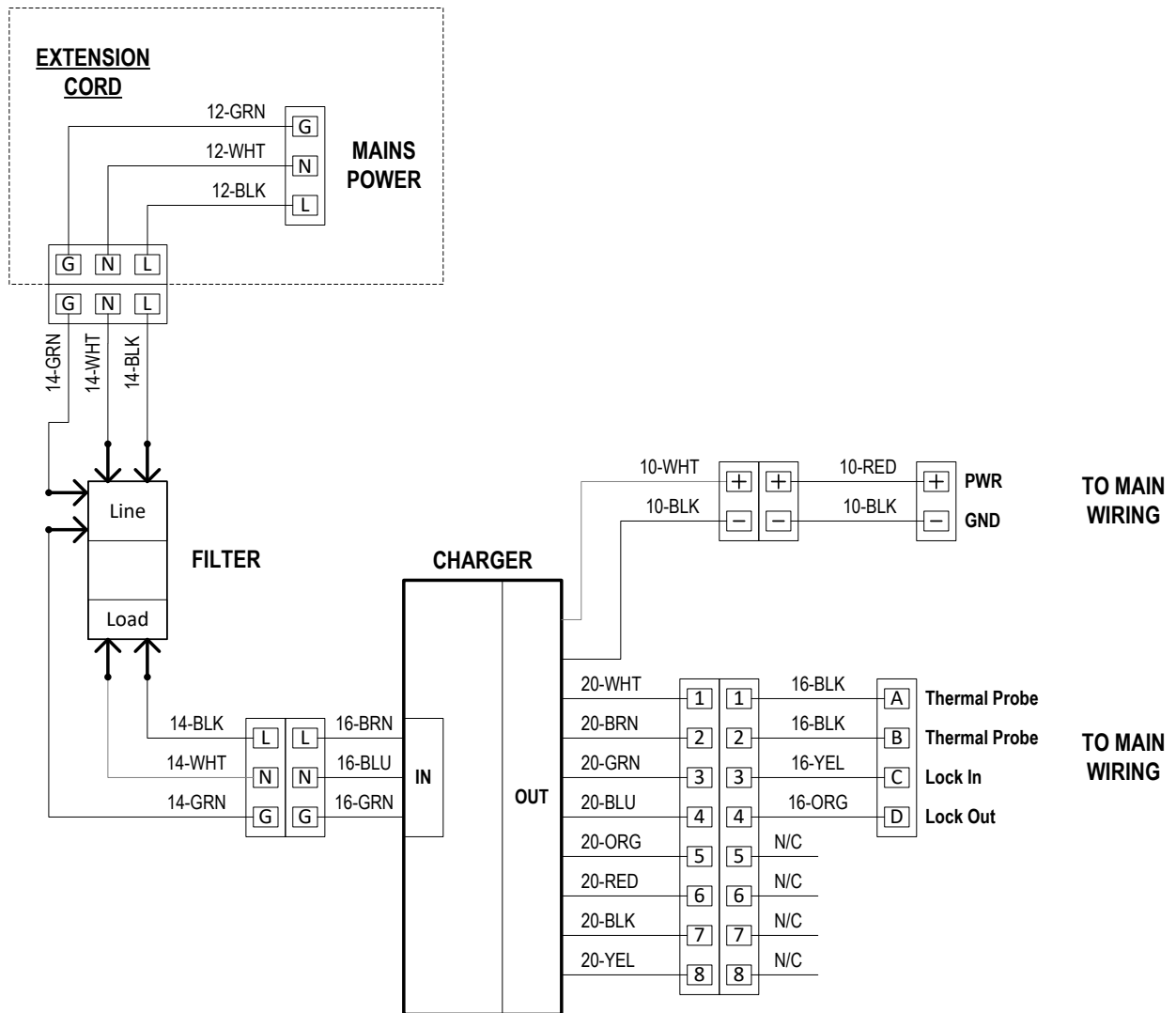

Wiring Diagrams

BATTERIES WIRING DIAGRAM

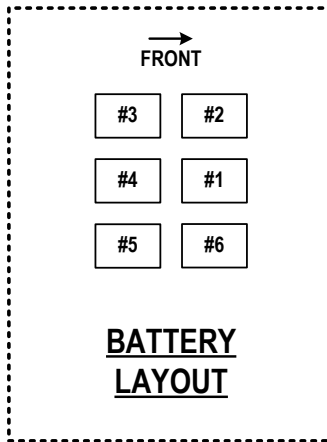
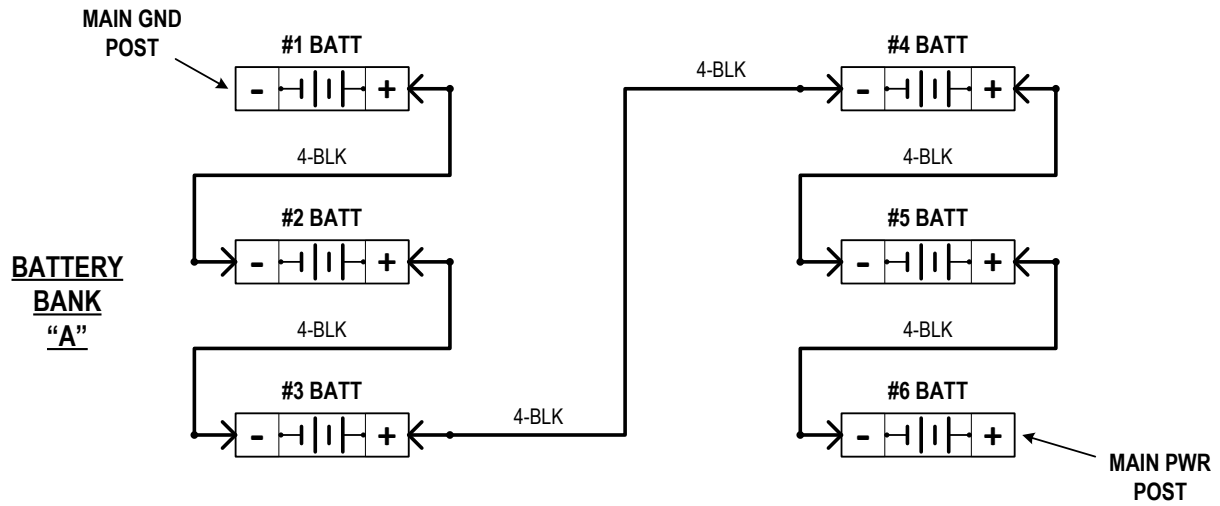

Warranty

National Flooring Equipment Inc. (referred to as "The Company") warrants that each new unit manufactured by The Company to be free from defects in materials and workmanship in normal use and service for a period of twelve (12) months from date of shipment from The Company to the end user. If shipment to end user is from a Distributor, The Company may honor warranty for up to 15 months from initial shipment from the Company if the end user can provide documentation of receipt date. Accessories or equipment furnished and installed on the product by the Company but manufactured by others, including but not limited to: engines, motors, electrical components, transmissions etc., shall carry the accessory manufacturers own warranty. Battery warranties are prorated over the warranty period. Customer is responsible for the inspection of equipment or parts upon delivery. **Freight damages are excluded from this warranty.**

The Company, at its determination of defect, will repair or replace any product or part deemed to be defective in material or workmanship within specified warranty time period. All product determinations and / or repairs will take place at The Company repair facility or at a certified warranty location designated by The Company. The Company will coordinate and be responsible for all freight expenses associated with valid warranty claims. Freight and shipping expenses associated with abuse or misuse will be back charged to the Distributor/Customer. The Company reserves the right to modify, alter or improve any part / parts without incurring any obligation to replace any part / parts previously sold without such modified, altered or improved part / parts. In no event shall the seller or manufacturer of the product be liable for special, incidental, or consequential damages, including loss of profits, whether or not caused by or resulting from the negligence of seller and / or the manufacturer of the product unless specifically provided herein. **This warranty shall not apply to any products or portions there of which have been subjected to abuse, misuse, improper installation or operation, lack of recommended maintenance, electrical failure or abnormal conditions, and to products which have been tampered with, altered, modified, repaired, reworked by anyone not approved or authorized by the Company or used in any manner inconsistent with the provisions of the above or any instructions or specifications provided with or for the product.** Any and all unauthorized onsite warranty work conducted by unauthorized personnel or any outside person(s), is not covered by The Company unless the work has been pre-authorized by a predetermined manufacturer representative. This warranty excludes wearable parts and/or consumables.

Defective or failed material or equipment shall be held at the purchaser's premises until authorization has been granted by The Company to return or dispose of defective products. Products returned to The Company for inspection must be returned with a manufacturer authorized Return Material Authorization (RMA), and must be packaged to The Company's specifications to avoid damage during shipment. Any unauthorized return of equipment will be declined at the dock by The Company. Any non-approved items returned with approved returned items are subject to rejection and will not be credited. Credit will be issued for material found to be defective upon The Company's inspection based on prices at time of purchase.

TO OBTAIN SERVICE CONTACT NATIONAL FLOORING EQUIPMENT, INC. TOLL FREE AT 800-245-0267 FOR A REPAIR AUTHORIZATION NUMBER. COD FREIGHT RETURNS WILL NOT BE ACCEPTED. FREIGHT COLLECT SHIPMENTS WILL NOT BE ACCEPTED. WARRANTY REPAIRS MUST BE ACCOMPANIED BY DATE OF PURCHASE RECEIPT AND A RETURN/ REPAIR AUTHORIZATION NUMBER.

RETURN/REPAIR AUTHORIZATION NUMBER: _____

MACHINE SERIAL NUMBER: _____



Made in America Since 1968

9250 Xylon Avenue N • Minneapolis, MN 55445 • U.S.A.
Toll-free 800-245-0267 • Phone 763-315-5300 • Fax 800-648-7124 • Fax 763-535-8255
Web Site: www.nationalequipmentdirect.com • E-Mail: info@nationalequipment.com