

126

SINGLE PULL BINDER INSTRUCTION MANUAL

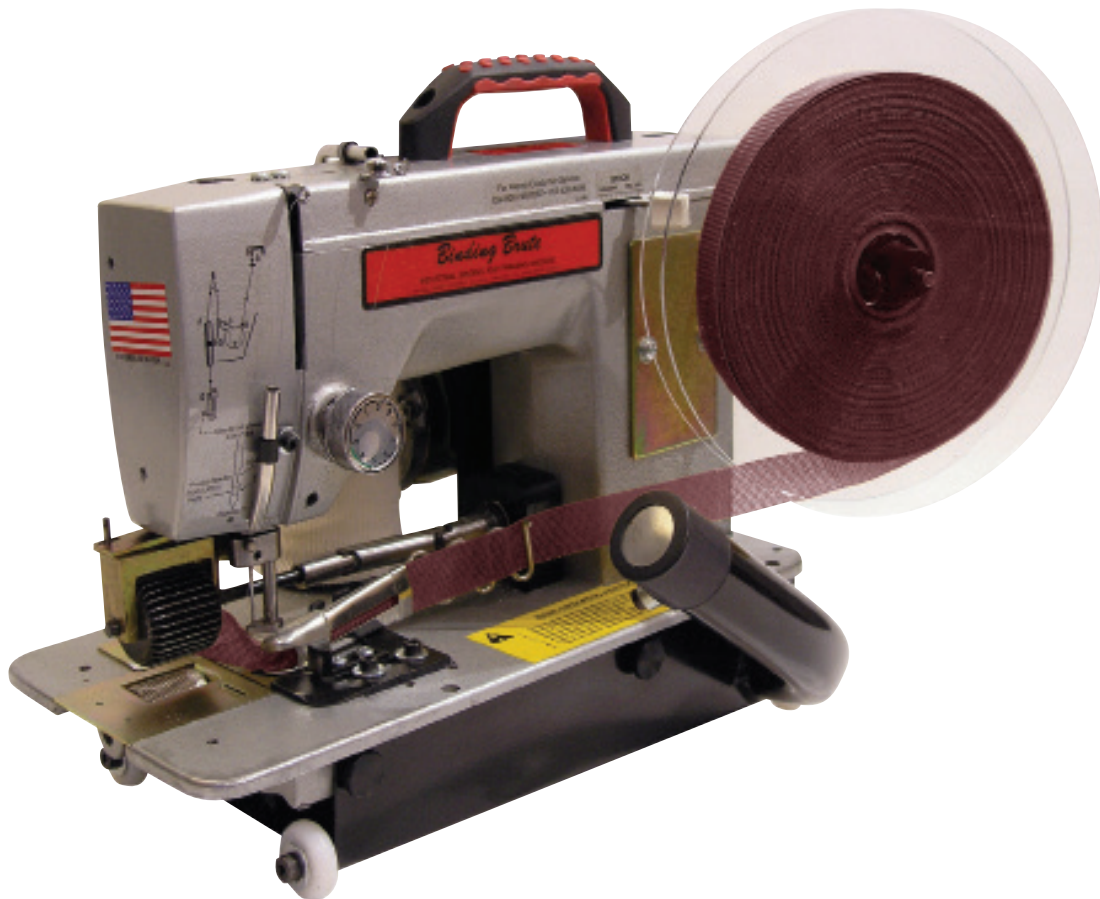

Read Manual Before Operating Machine

DISCLAIMER

All efforts have been made to ensure the accuracy of the information in this manual. However, should any errors be found, National Flooring Equipment (NFE) would greatly appreciate being notified. Due to continual development of our equipment, NFE cannot take responsibility for any incorrect action taken, or not, due to errors or omissions in this manual that may result from negligence, accident, or any other cause.

No part of this manual may be used or reproduced in any form whatsoever without the written permission of NFE. The contents of this manual are subject to revision without notice. All rights reserved.

The use of third-party spare parts may adversely affect the performance of the product and could invalidate the warranty.

Nationalequipment.com

Toll Free: 800.245.0267 | Main: 763.315.5300

9250 Xylon Avenue North | Minneapolis, MN 55445

© 2015, National Flooring Equipment, Inc.

Features and Specifications	5
Features	5
Specifications	5
Safety	6
General Rules for Safe Operation	6
Characteristics of a Defensive Operator.....	7
Grounding.....	7
Grounded Tools: Tools with Three Prong Plugs	7
Extension Cords	8
Guidelines for Using Extension Cords	8
Machine Operation	9
Introduction.....	9
Threading Instructions.....	9
Thread Tension.....	11
Proper Thread Tensions.....	11
Upper Thread Adjustments	11
Lower Thread Adjustments	11
Installation and Threading of Binding Tape	12
Preparation for Stitching	12
Stitching	12
Stitching.....	13
To change direction of stitching.....	13
To remove carpet	13
Regulation Width of Zig-zag Stitch.....	13
Folders.....	14
Machine Maintenance	15
Lubrication	15
Shuttle Area Lubrication	15
Entire Machine Lubrication	15
Operation Tips	15
Adjustments.....	16
To Check Needle Height Adjustment	16
To Adjust Needle	17
Needle to Hook Clearance.....	18
Race Cover Spring Clearance Adjustment	19
Bobbin Case	19
Troubleshooting Guide	20
Binding Tips	22
Binding	22
Binding Corners	22
Base Binding.....	22
Folder Adjustments	23
Folder Adjustments	23

Binding & Stitching Instructions.....	24
Normal Outside Corner.....	24
Optional — Double Covered Corners.....	25
Sewn Corners.....	25
Inside Corners.....	26
Complete Parts List.....	28
Complete Parts List.....	28
Accessories.....	29
Attachments.....	29
Parts List and Diagrams	31
#126-03-1 Round Zig Zag Control	31
#126-03-2 Zig Zag Lever in Middle of Machine.....	31
#126-03-3 Zig Zag Lever behind Binding Tape Disks.....	31
Bobbin Case.....	31
Frame Parts.....	32
Pan Parts.....	33
Drive Motor Parts.....	34
Needle Plate Parts.....	35
Internal Parts.....	36
Accessories & Attachments	39
#126E Clear Thread	39
#126EH Clear Heavy Duty Thread.....	39
Bobbins.....	39
Needles.....	39
Speed Control #126-N	39
Battery and Charger.....	40
Base Attachments.....	40
#126-P217 Accessory Kit.....	40
#1840 Tweezers.....	41
Binding and Serging Attachments.....	41
Assembled Machine Pictures.....	42
Top View.....	42
Bottom View.....	42
End View.....	43
Warranty.....	44

Features and Specifications

Features

As with our many other products offered to the carpeting industry, NFE stands ready to warrant and assist our customers in any way possible. Should it be necessary for you to require service or assistance, please contact our sales or service representative at 800-245-0267.

With the DVD and maintenance portion of this manual, it is our objective to provide you with both pictorial and written information necessary to assist you in proper servicing and maintenance of your Binding Brute.

Specifications

Heavy Duty Motor - with non-slip gear reduction drive and heavy duty motor made in the USA.

Folder - includes a 7/8" folder that accommodates binding and serging tape. Accommodates a variety of folder sizes.

Maximum Binding Strength - straight or zigzag lockstitch for maximum binding strength.

Ergonomic Handle - ergonomically designed handle gives better visibility and reduces hand and arm fatigue.

Ball Bearing Wheels - built in heavy duty ball bearing wheels.

Safety

General Rules for Safe Operation

READ AND SAVE ALL INSTRUCTIONS FOR FUTURE USE. Before use, ensure operators read and understand this manual. Read and understand labeling on machine and components. All operators must view the instruction video. Extra copies of the manual and video are available.

1. **KNOW YOUR EQUIPMENT:** Read this manual carefully to learn equipment applications and limitations, potential hazards associated with this type of equipment. Keep this manual with the equipment it is associated with.
2. **GROUND YOUR EQUIPMENT:** See Grounding Page 7.
3. **AVOID DANGEROUS ENVIRONMENTS:** Do not use in rain, damp or wet locations, or in the presence of explosive atmospheres (gaseous fumes, dust or flammable materials). Remove materials or debris that may be ignited by sparks.
4. **KEEP WORK AREA CLEAN AND WELL LIT:** Cluttered, dark work areas invite accidents.
5. **DO NOT USE ON STEPS.**
6. **DRESS PROPERLY:** Do not wear loose clothing. These may be caught in moving parts. When working wear gloves and insulated non-skid footwear. Keep hands and gloves away from moving parts.
7. **KEEP BYSTANDERS AWAY:** Children and other bystanders should be kept at a safe distance from the work area to avoid distracting the operator and contacting the equipment or extension cord. Operator should be aware of the proximity of bystanders. This appliance is not intended for use by persons (including children) with reduced physical, sensory or mental capabilities or lack of experience and knowledge. Equipment is not to be used by children.
8. **USE PROPER ACCESSORIES:** Using accessories that are not recommended may be hazardous. Be sure accessories are properly installed and maintained. Do not delete a guard or other safety device when installing an accessory or attachment.
9. **CHECK FOR DAMAGED PARTS:** Inspect guards and other parts before use. Check for misalignment, binding of moving parts, improper mounting, broken parts and other conditions that may affect operation. If abnormal noise or vibration occurs, turn off immediately and have the problem corrected before further use. Do not use damaged equipment. Tag damaged equipment "DO NOT USE" until repaired. Missing or damaged parts should be properly repaired or replaced immediately. For all repairs, use only identical National replacement parts.
10. **GUARD AGAINST ELECTRIC SHOCK:** Prevent body contact with grounded surfaces such as pipes, radiators, ranges and refrigerators. When making cuts, always check the work area for hidden wires or pipes. Hold your equipment by insulated nonmetal grasping surfaces. Use a Ground Fault Circuit Interrupter (GFCI) to reduce shock hazards.
11. **AVOID ACCIDENTAL STARTING:** Be sure equipment is turned off before plugging in. Do not use a equipment if the power switch does not turn the equipment on and off.
12. **DO NOT FORCE EQUIPMENT:** Equipment will perform best at the rate for which it was designed. Excessive force only causes operator fatigue, increased wear and reduced control.
13. **KEEP HANDS AWAY FROM ALL CUTTING EDGES AND MOVING PARTS.**
14. **DO NOT ABUSE CORD:** Never unplug by pulling the cord from the outlet. Pull plug rather than cord to reduce the risk of damage. Keep the cord away from heat, oil, sharp objects, cutting edges and moving parts.
15. **STAY ALERT:** Watch what you are doing, and use common sense. Do not use when you are tired, distracted or under the influence of drugs, alcohol or any medication causing decreased control.
16. **STARTING MACHINE:** On/Off switch must be in off position before connecting to power source.
17. **UNPLUG EQUIPMENT:** When not in use and before changing accessories or performing recommended maintenance, unplug machine.
18. **MAINTAIN LABELS AND NAMEPLATES:** These carry important information. If unreadable or missing, contact National for a replacement.
19. **MACHINE IS HEAVY, DO NOT DROP.** Ensure proper lifting procedures are followed when transporting.

Characteristics of a Defensive Operator

A Good Operator is a "Defensive" Operator!

QUALITIES INCLUDE:

Education: Familiarize oneself with machine operation and work area.

Alert: Stays alert at all time and never lets guard down.

Skills: Only performs duties he/she is qualified to do. Always tries to improve.

Judgement: Uses sound judgement. Does not take unnecessary risks.

Common Sense: Applies knowledge in practical situations.

Recognizes the Hazards: Maintains alertness. Anticipates danger.

Understands the Defense: Knows that safety isn't an accident...it's a thinking person's choice.

Acts Correctly: Does not give in to peer pressure. Performs correctly when supervised or not.



WARNING: ELECTRICAL CORDS CAN BE HAZARDOUS. MISUSE CAN RESULT IN FIRE OR DEATH BY ELECTRICAL SHOCK. READ CAREFULLY AND FOLLOW ALL DIRECTIONS.

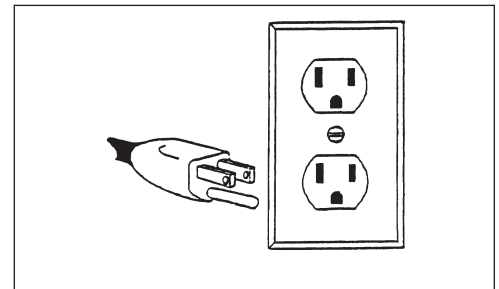

FIG. A

Grounding

Jobsite receptacles can vary. Check the voltage at different receptacles on the jobsite for a more accurate voltage reading. 15 amp GFI outlets are not recommended.

Grounded Tools: Tools with Three Prong Plugs

Equipment marked "Grounding Required" have a three wire cord and three prong grounding plug. The plug must be connected to a properly grounded outlet (Figure A). If the equipment should electrically malfunction or break down, grounding provides a low resistance path to carry electricity away from the user; reducing the risk of electric shock.

The grounding prong in the plug is connected through the green wire inside the cord to the grounding system in the equipment. The green wire in the cord must be the only wire connected to the equipment's grounding system and must never be attached to an electrically "live" terminal.

The equipment must be plugged into an appropriate outlet, one which is properly installed and grounded in accordance with all codes and ordinances. The plug and outlet should look like the example in Figure A.

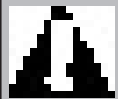

CAUTION: IMPROPERLY CONNECTING THE GROUNDING WIRE CAN RESULT IN THE RISK OF ELECTRIC SHOCK. CHECK WITH A QUALIFIED ELECTRICIAN IF YOU ARE IN DOUBT AS TO WHETHER THE OUTLET IS PROPERLY GROUNDED. DO NOT MODIFY THE PLUG PROVIDED WITH THE EQUIPMENT. NEVER REMOVE THE GROUNDING PRONG FROM THE PLUG. DO NOT USE THE EQUIPMENT IF THE CORD OR PLUG IS DAMAGED. IF THE PLUG WILL NOT FIT THE OUTLET, HAVE A PROPER OUTLET INSTALLED BY A QUALIFIED ELECTRICIAN.

Extension Cords

Grounded equipment requires a three wire extension cord. Double insulated equipment can use either a two or three wire extension cord. As the distance from the supply outlet increases, you must use a heavier gauge extension cord. Using extension cords with inadequately sized wire causes a substantial drop in voltage, resulting in loss of power and possible equipment damage.

The smaller the gauge number of the wire, the greater the capacity and larger diameter of the cord. For example, a 2.5 mm 10 gauge cord can carry a higher current than a 2 mm 12 gauge cord. When using more than one extension cord to make up the total length, be sure each cord contains at least the minimum wire size required. If you are using one extension cord for more than one tool, add the nameplate ampere and use the sum to determine the required minimum wire size.

Guidelines for Using Extension Cords

- If you are using an extension cord outdoors, make sure it is marked with the suffix "W-A" to indicate that it is acceptable for outdoor use.
- Be sure your extension cord is properly wired and in good electrical condition. Always replace a damaged extension cord or have it repaired by a qualified person before using it.
- Protect your extension cords from sharp objects, excessive heat and damp or wet areas.
- Keep away from water. Do not use if wet.
- Inspect thoroughly before each use. DO NOT USE IF DAMAGED.
- Make sure equipment is not running before disconnecting cord.
- FULLY INSERT plug into outlet.
- Do not remove, bend or modify any metal prongs or pins of cord.
- Do not use excessive force to make connections.
- Do not connect a three prong plug to a two hole cord.
- Avoid overheating. Uncoil cord and do not cover it with any material.
- Do not walk on cord.
- Do not drive, drag or place objects over cord.
- Use a 2 mm (12 gauge), 120v cord, 15.24 m (50ft) maximum length with this machine.
- Regularly examine the supply cord for damage, such as cracking or aging. If damage is found, replace the cord before further use.
- Only replace the supply cord with the type specified in the instruction manual.

Machine Operation

Introduction

Each new Binder is furnished with the following items:

- Binding Tape Discs (2)
- Instruction DVD
- Instruction Manual
- Lubricant
- Binding Reel Centering Plug

Accessory Kit containing:

• Prewound Bobbins (8)	• 1/8" Allen Wrench
• Needles (1 -Ten Pack)	• 5/64" Allen Wrench
• Tweezers	• 3/32" Allen Wrench
• Binding Tape (1/2 gross)	• 5/32" Allen Wrench
• Serging Tape Sample	• Large Screwdriver (2)
• Thread Clippers	• Small Screwdriver (2)

NOTE: It is highly recommended you retain the box and packing your Binder was supplied in for storage, transporting or if necessary, to return the Binder for service. Replacement Shipping Cartons can be purchased.

For equipment to be returned, please call National at 1-800-245-0267.

Threading Instructions

1. Raise needle to highest point.
2. Raise the feed roller.
3. Thread by following the letters indicated in the illustration (See Figure B)
 - a. Upper Thread Guide
 - b. Enter Tension Discs
 - c. Exit Tension Discs
 - d. Take up Spring
 - e. Take up Lever
 - f. Lower Thread Guides
 - g. Needle Block
 - h. Needle (See Figure C).

NOTE: Assure thread is bottomed in the tension disc (B & C in Figure B). This is extremely important.

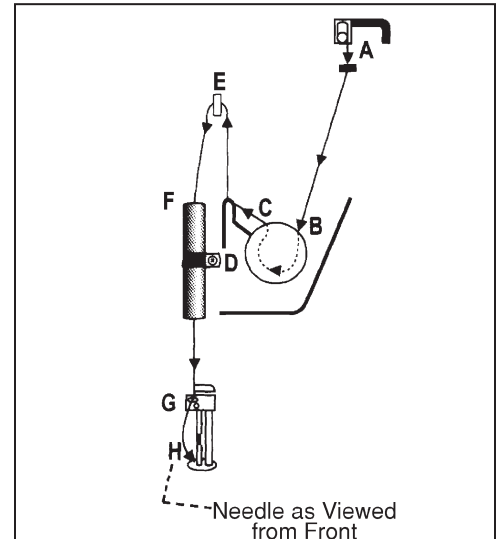

FIG. B

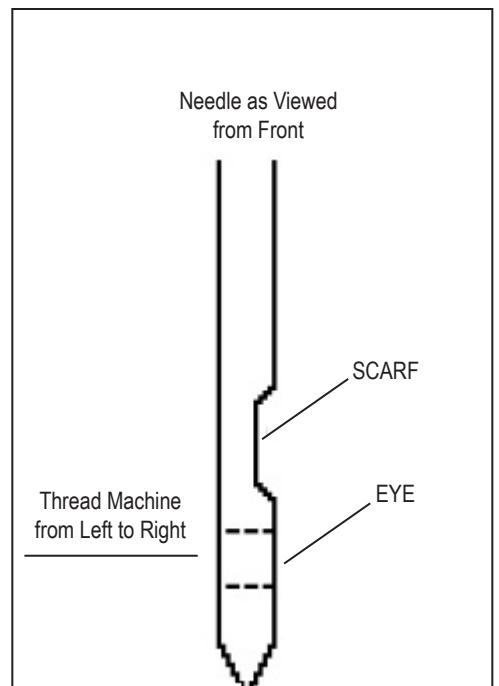

FIG. C



CAUTION: FOR YOUR SAFETY, DISCONNECT THE POWER SOURCE TO THE BINDER BEFORE ATTEMPTING TO SERVICE OR ADJUST THE MACHINE.

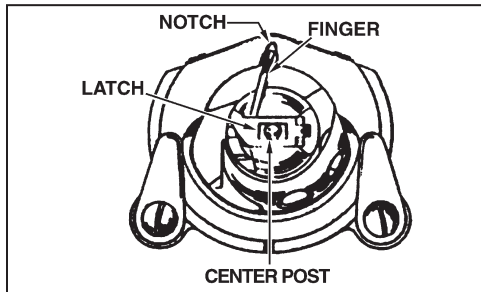

FIG. D



FIG. E

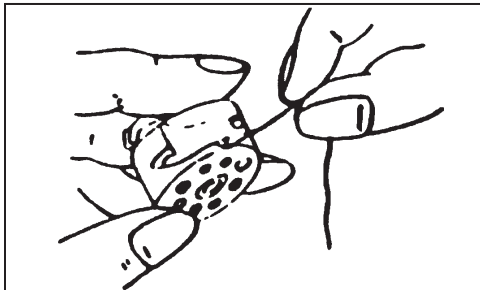

FIG. F

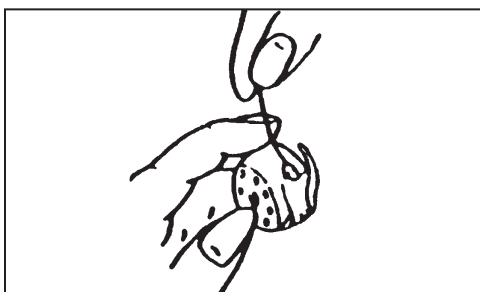

FIG. G

Threading Instructions (Cont'd)

4. Removal of Bobbin Case

- Raise feed roller.
- Rotate handwheel toward you until needle reaches its highest point.
- Tilt machine to rest on handwheel end. If you have binding wheels installed, use a small block to support machine on handwheel.
- Remove lower feed roller plate.
- Lift and grasp bobbin case latch (as illustrated).
- Remove case by pulling towards you.

5. Threading of Bobbin Case

- With bobbin and bobbin case being held as illustrated, and with approximately 5 to 6 inches of thread for feeding, insert bobbin into case (See Figure E).
- Pull thread through slot in the bobbin case (See Figure F).
- Continue by pulling thread under tension spring and up through slot in spring (See Figure G).
- Put thread through hole in bobbin case arm leaving approximately 5 to 6 inches of bobbin thread hanging from the arm.

NOTE: To check for proper thread feed tension, see "Thread Tension" on Page 11.

6. Installation of Bobbin Case

- Lift and grasp bobbin case latch and with the arm aligned with the notch in the shuttle race cover, slide the bobbin case fully onto the center post (See Figure D). During this operation, it is helpful to also hold the thread with the bobbin case to prevent the bobbin from dropping out of the case.
- Trim the bobbin thread to approximately 2 inches.

7. Needle Replacement

- To remove, rotate the handwheel towards you until it reaches its highest point. Using a 5/64 allen wrench, (provided in the kit), loosen the set screw above the needle and remove needle.
- To replace, grasp the needle with tweezers, and as viewed from the feed side of the machine, position needle with the long groove facing left and the notch side facing right. Feed the point into the lower guide, and then the other end up into the clamp. Assure needle is bottomed in clamp before tightening set screw.

DO NOT OVER TIGHTEN.



CAUTION: REPLACEMENT NEEDLES MUST BE OF THE CORRECT TYPE AND INSTALLED CORRECTLY FOR PROPER MACHINE OPERATION.



PROPER NEEDLE TYPE FOR YOUR MACHINE WILL BE INDICATED BY PACKET OF NEEDLES ENCLOSED IN KIT.

THE BINDERS ARE EQUIPPED WITH A "SCHMETZ NO. 23" HEAVY DUTY NEEDLE. AS AN OPTION, THE "SCHMETZ NO. 22" NEEDLE CAN BE USED. THE PRINCIPLE DIFFERENCE IS, THE NO. 23 IS SLIGHTLY LARGER IN DIAMETER, THEREFORE STIFFER AND TENDS TO DEFLECT LESS. NEEDLE TO HOOK SPACING MAY CHANGE AND THE ADJUSTMENT SHOULD BE CHECKED PER THE ADJUSTMENT INSTRUCTION SHEET. THE DIAMETER DECREASE WILL RESULT IN A SMALLER PENETRATION HOLE IN THE FABRIC.

Thread Tension

Proper Thread Tensions

Proper thread tensions are important to obtain the optimum stitch appearance, proper knot location and tensions within the fabrics being sewn.

*Indications of proper and improper thread tensions.

When the upper and lower thread tensions are correct, the threads are knotted in the fabric center as in this illustration (See Figure H).

With excessive tension on the upper thread, the result will be looping on the top of the fabric as in this illustration (See Figure I).

With excessive tension of the lower thread, the result will be looping on the bottom of the fabric as in this illustration (See Figure J).

Upper Thread Adjustments

Rotation of the Tension control clockwise will increase thread tension. Conversely, counterclockwise will decrease thread tension.

NOTE:

Make small adjustments (single number movements) until desired results are achieved. It is also appropriate at this point to note that whenever you re-thread the machine, to make sure the thread is properly seated between the tension discs. Lack of upper tension can result in looping of upper thread on bottom of carpet.

Lower Thread Adjustments

Remove bobbin case. Check that the bobbin spool is properly threaded in the case. To test tension, hold the thread end and allow the bobbin case to hang freely. Give the thread a slight tug upward. If the tension is correct, the weight of the case will cause approximately 1" of thread to feed out.

To increase tension, turn the small slot screw on the case clockwise. Conversely, counterclockwise will decrease.

Note: Rotate the adjusting screw no more than 1/8" to 1/4" turn at a single time, until desired result are achieved. Recheck spool threading after each test and before reinstalling case in machine. Over time, thread dust will accumulate between the spring and case and can cause erratic tensions. To correct, remove screw and spring and clean.

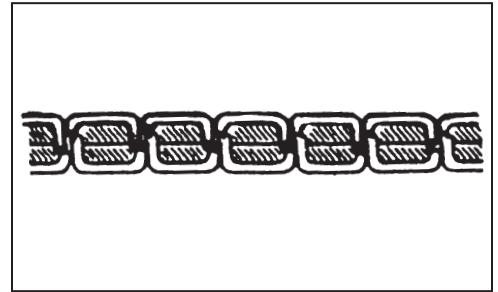

FIG. H

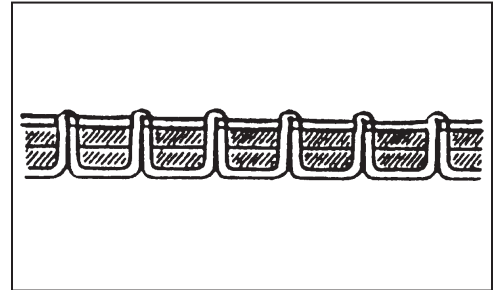

FIG. I

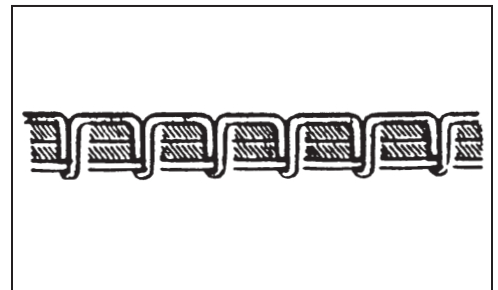

FIG. J

Thread Tension (Cont'd)

Installation and Threading of Binding Tape

Included with your machine are:

- Large Black Plastic Discs (2)
- Tape Reel Centering Plug
- Binding Tape (1/2 Gross)

Mount the tape reel:

- Place the inner disc on spindle with smooth side to face tape reel.
- Slide the plug onto spindle.
- Place tape reel on centering plug in a manner that tape will feed off reel in a CLOCKWISE direction.
- Slide remaining disc onto spindle. Allow space for free tape feed.
- Lightly tighten thumb screw.

Remember...Tape reel MUST roll freely between discs.

Threading Tape

- Trim tape end to provide a long sharp point.
- Start tape end into folder inlet (do not thread through tension spring at this time).
- Using a tweezer point in the folder slot, push the tape until you can grasp tape end at folder exit.
- Pull several inches of tape through folder and back under the needle, as it would appear while stitching.
- Tape as being fed from reel to folder, can now be through the tape guide closest to the folder (one guide is recommended).

Preparation for Stitching

- Set the Zig-zag-straight stitch selector to Zig-zag.
- Grasp the upper thread and tape end in your left hand, and with a slight pulling pressure away from you, and in a straight line, run machine in short bursts until stitching occurs in binding tape.

Stitching

- Raise feed roller.
- Rotate hand wheel towards you until needle is at highest point.
- Insert material edge into folder groove and up to needle foot.
- Drop feed roller.
- Begin sewing. (It may be necessary to push material slightly at this point to engage it under feed roller).

Stitching

While sewing, NEVER pull on carpet or machine. This can cause needle deflection which can result in needle breakage and/or damage to the bobbin/shuttle mechanism.

To change direction of stitching

1. Stop sewing and if necessary, rotate hand wheel towards you until needle is in carpet.
2. Raise feed roller.
3. Alter direction of material (or machine).
4. Lower feed roller and resume sewing.

To remove carpet

1. Raise feed roller.
2. Rotate hand wheel toward you until needle is at highest point.
3. Pull carpet out to your left (or move machine to the right).
4. Cut thread and binding.

Regulation Width of Zig-zag Stitch

The width of zig-zag stitch is regulated by the stitch pattern control knob or lever. For instance, to "0" is straight stitch, and to "5" is max zig-zag stitch.

Turn the hand wheel toward you slowly with your right hand until needle enters needle plate and returns to highest point. Avoid making these changes with the needle below the needle plate or in carpeting.

IMPORTANT:

Certain carpet types, weights and those with a heavy or rubberized backing, may prove difficult to bind in the full zig-zag mode.

If this occurs, using a scrap piece, test in the full straight stitch mode. Then gradually select up to a zig-zag pattern allowable. This is the recommended procedure for Berbers.

*It should be noted that carpet types such as Berber or those with a stiff or heavy backing may require a sewing softener application prior to binding. Also, use of a #23 needle is recommended for Berbers.

Also, a good gauge for carpet height capability is one that will easily pass through the folder throat. Above that, beveling is necessary. A rule of thumb is, weights above 40 oz. should be beveled for best results.

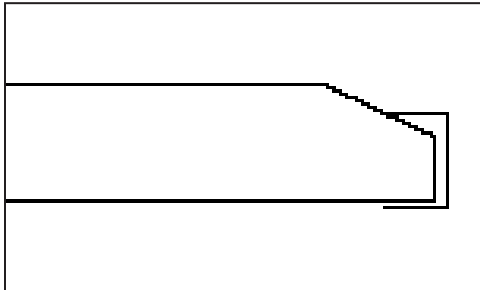

FIG. K

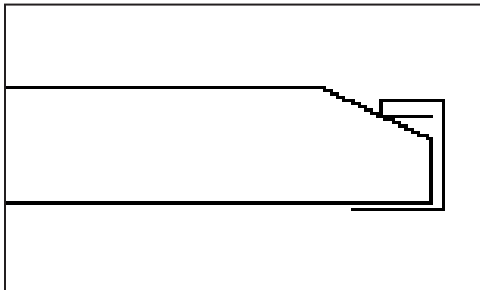

FIG. L

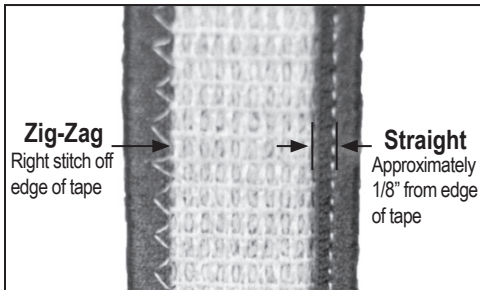

FIG. M



FIG. N

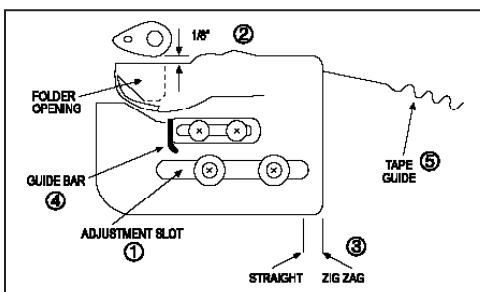

FIG. O

Folders

The standard folder shipped with the machine is a 7/8" raw edge. This folder is designed to be used with polyester binding.

For cotton binding, National can supply a 3/4" folder model. It is recommended that you supply National with a sample roll of the cotton binding for testing, and to specify the carpet type you intend to bind.

Other folder types available are as follows:

Figure K: 3/4", 7/8", 1 1/4", 2", 2 1/4", 3", etc.

Figure L: 1 1/4" Single Tuck (Tucks top edge under)

The folder supplied with the machine has been tested at both stitch extremes. (Full straight and Full zig-zag).

As seen from the bottom of the carpet correct stitching should appear like this 7/8" binding tape example in Figure M.

As shipped, the folder is positioned to correctly bind in the full zig-zag mode (See Figure N). Straight stitching will require moving the folder to the left. Adjustment instructions as seen in Figure O follows:

- The slot in the folder bracket allows it to be moved left or right when changing between zig zag and straight on the stitch control.
- Caution: Keep the presser foot needle block assembly from hitting the folder by allowing approximately 1/8" space between them.
- When correctly adjusted the folder positions can be marked on a piece of masking tape applied at the front edge of the folder, or marked with a permanent marker.
- Use of the guide bar is optional. If used it should be far enough to the right so it doesn't block the folder opening.
- Threading the binding tape through only one of the tape guides (the one closest to the opening) is recommended.
- If stitch misses the tape on the bottom, refer to "Adjustments" heading.

Machine Maintenance

Lubrication

Thorough and regular lubrication of your machine is essential to proper operation and long service.

Shuttle Area Lubrication

Inspect and, if necessary, clean each time you change bobbins or after a maximum of one hour of continuous running. Lubricate after cleaning with the type of lubricant supplied with machine.

Remove lower feed roller plate, bobbin case, hook retainer and hook.

Thoroughly clean the race cover, hook and hook inner race (an old needle works well to remove grime from inner race corners).

Apply a light film of lubricant on the hook, inside of race cover and inner race.

Entire Machine Lubrication

Follow this procedure after approximately eight (8) hours running time.

Remove the top cover. Slowly rotate the handwheel towards you and observe where rotation occurs. Apply the oil at these points, the oil port for the main shaft bearing, oil ports on the crank journals beneath the stitch selector mechanism, and all the pivot and sliding areas associated with the stitch selector.

Repeat this procedure in the needle bar area (behind the front cover) and the lower area (after removing the pan). Never lubricate the tension control. This is also a good time to check and re-tighten all screws.

Operation Tips

- Always check the needle condition and the amount of bobbin remaining before starting a job.
- It is good practice to run a short strip of scrap whenever changing carpet types to check for stitch placement and binding fold.
- Never pull on machine or carpet during operation. The feed roller and needle stroke is timed to prevent carpet movement while needle is in carpet. When binding corners with feed roller up, use care in feeding carpet.
- Always use a softener when binding Berbers. It is good practice to use no more than 1/2 of the zig zag range and to install a #23 needle.
- Always use a lubricant when binding unibond/unitary backed carpet. The thread and needle will pick up the plastic from the backing, transfer it to the shuttle parts, and cause thread tangling and breakage.
- If you hear the needle hitting, stop and inspect the shuttle area parts and needle the first opportunity you have.

Adjustments

To Check Needle Height Adjustment

Note: All screw locations marked in red are permanent and should not be adjusted.

This adjustment should be checked if machine skips stitches, after machine jams or a needle has broken.

Install new needle incorrectly with the scarf to the outside (left) rather than inside (right) (See Figure P and Figure Q).

1. Remove shuttle access plate.
2. Remove bobbin case.
3. Remove race cover.
4. Leave hook in shuttle.
5. Reverse needle 180° so scarf faces out (See Figure R). Tilt machine so that it is at an angle so you can see the shuttle area. as you turn the handwheel counter-clockwise, the hook will travel clockwise; reverse rotation and travel counterclockwise to a position where the point of the hook is approximately 1/8" behind the needle and reverse the rotation again. When the point of the hook is just in line with the back side of the needle, the point of the hook should be in the center of the scarf (approximately 1/8" above the center of the eye of the needle).

Note: (For adjustments see page 24). Make sure hook is always in full contact with the bottom most part of driver. When completed, install the needle properly with the scarf to the right.

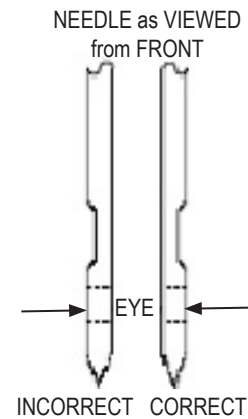

FIG. P

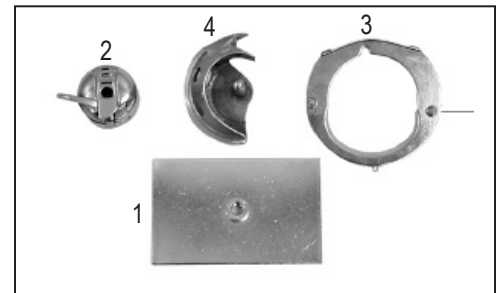

FIG. Q

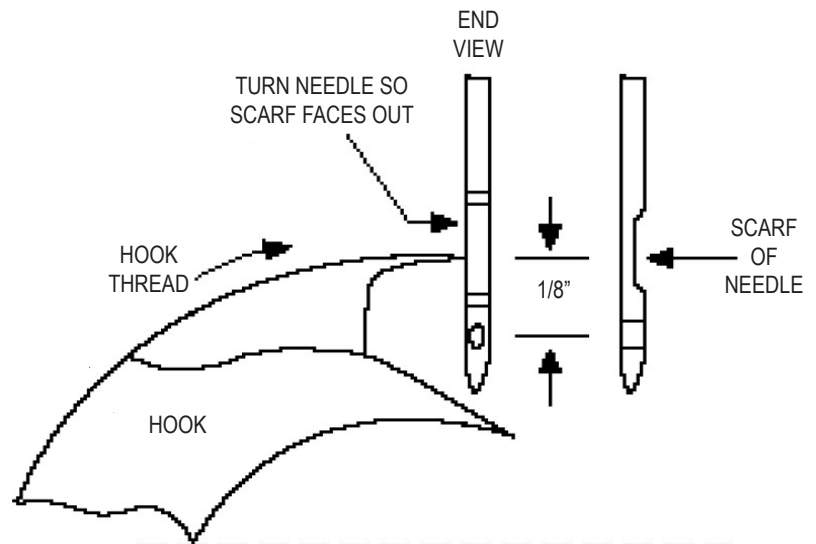

FIG. R



FIG. S

To Adjust Needle

1. Loosen set screw located in needle bar drive collar (part# 126-164, See Figure S).
2. Slide needle bar (part #126-172) slightly up or down.
3. Tighten set screw in drive collar.
4. Recheck needle height adjustment (See "To Check Needle Height Adjustment" on previous page).

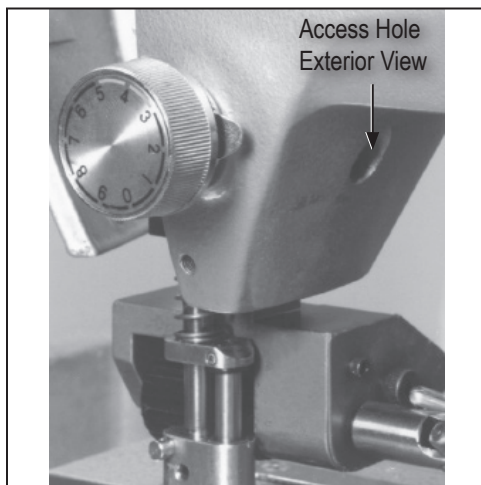

FIG. T

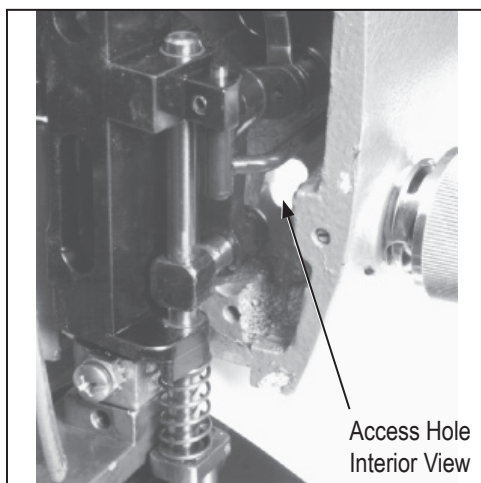

FIG. U

Adjustments (Cond't)

Note: Needle to hook clearance and race cover spring clearance seldom change or need adjustment.

Needle bar height may change due to jamming the machine or breaking a needle and should be checked if stitches are skipped or thread breaks.

Needle to Hook Clearance

1. Remove: Lower feed roller plate (Model 126), pan, bobbin and race cover.
2. Clean the shuttle area, hook and race cover prior to adjusting.

To Check:

Install new needle backwards with the scarf to the outside (left) rather than inside (right) (See Figure Y).

Hold machine at an angle so that the hook stays in place and the shuttle area is visible. Turn handwheel counter-clockwise until the point of the hook passes behind the needle. Stop when the point is approximately 1/8" past the needle (See Figure V). The hook should just touch, but not deflect the needle (See Figure W). This setting should be made in the zig zag position and the needle checked so it does not deflect on either the inside or outside stitch.

If adjustment is necessary, loosen Screw 'A' (Figure X), (Part # 126-137) on shuttle drive clamp (Part # 126-139) and move shuttle body left or right as necessary (See Figure X). Tighten screw 'A' slightly. Because loosening Screw 'A' also allows the shuttle assembly to rotate, the race cover spring clearance should also be checked.

For more information, see "Race Cover Spring Clearance Adjustment" procedure.

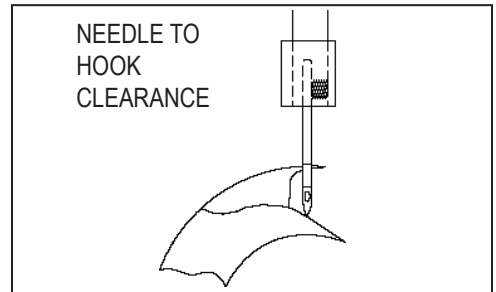

FIG. V

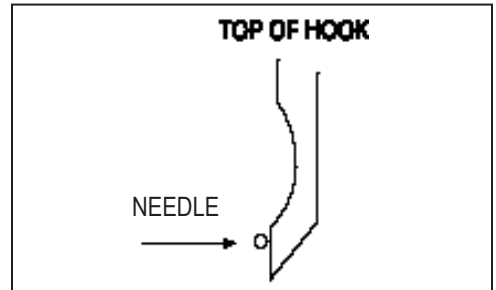

FIG. W

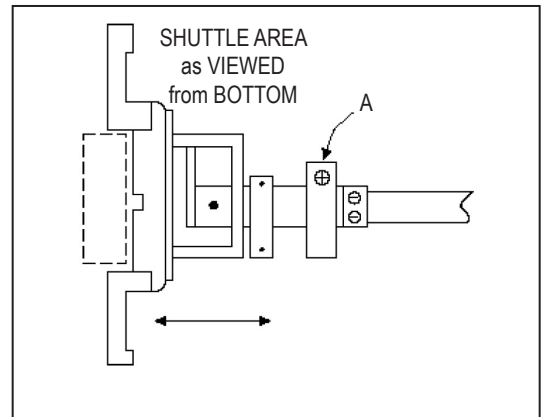

FIG. X

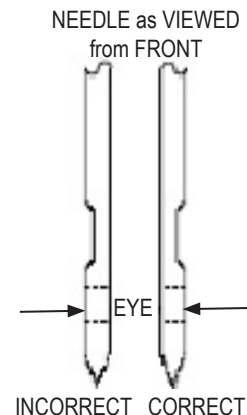

FIG. Y

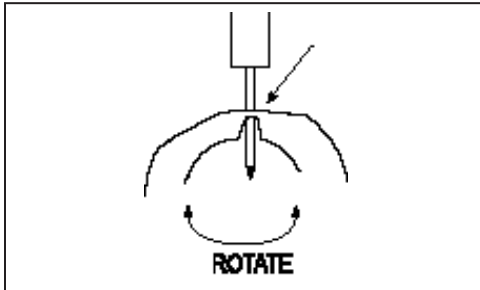

FIG. Z

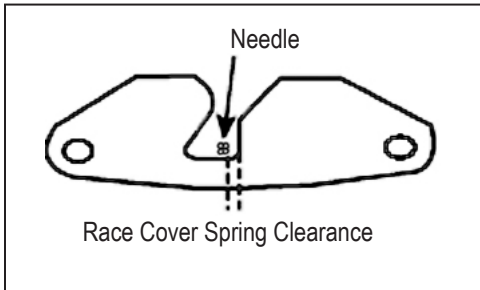

FIG. AA

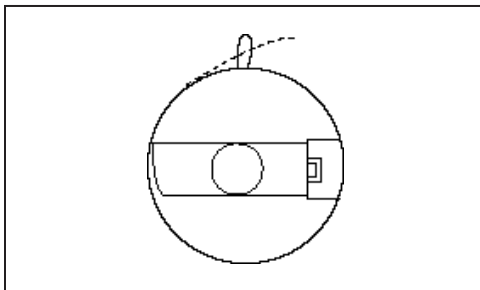

FIG. BB

Race Cover Spring Clearance Adjustment

- Remove the hook and install the race cover part# 126-140B.
- Handwheel the machine. The needle should be centered in the race cover ellipse (notch). Figure Z. If not centered, loosen Screw 'A' (Figure X) and rotate shuttle.
- Proper adjustment will result in the needle passing through the race cover spring as shown in Figure AA. Tighten Screw 'A' (Figure X), but do not over-tighten and cause the shaft to bind up. Install hook. Recheck needle to hook clearance.
- Important: When adjustments are completed install the needle properly. Scarf (flat side) on right hand side. Symptoms of a problem with this adjustment are dents on the race cover spring caused by the needle hitting it.

Bobbin Case

- This machine uses bobbin case with an eyelet: Part #126-112-1.
- Thread must pass through eyelet in bobbin case for proper operation as shown in Figure BB. Tension on the bobbin thread should be light.
- You have a #23 needle in machine. When ordering a replacement needle, ask for a size #23 needle and the applicable part number.

Part No.	Qty.
126-B2A	10 Pack
126-B2	100 Pack

Troubleshooting Guide

Problem	Cause	Solution
Skipping	<ul style="list-style-type: none"> a. Bad needle b. Dirty shuttle area c. Needle height or clearance out of adjustment d. Damage to shuttle hook or race cover spring 	<ul style="list-style-type: none"> a. Check needle b. Clean shuttle area c. Check adjustment d. Check shuttle hook & race cover spring -- repair/replace
Breaking Needles	<ul style="list-style-type: none"> a. Needle not installed properly b. Operator forcing carpet or machine c. Race cover spring clearance improper d. Carpet type (i.e. Berbers) 	<ul style="list-style-type: none"> a. Check needle b. Let machine do the work c. See instruction manual d. Test on another type of carpet, use softener on Berber
Upper Thread Breaking	<ul style="list-style-type: none"> a. Needle clearance out of adjustment b. Bad needle c. Upper tension set too high d. Carpet Type e. Dirty Shuttle f. Burrs on shuttle area g. Burrs on bottom of needle plate h. Bad upper thread i. Threading wrong j. Needle height k. Splice knot in threadspool 	<ul style="list-style-type: none"> a. Check adjustment b. Check needle c. Check tension d. Test on another type of carpet e. Clean shuttle area f. Inspect shuttle parts and deburr g. Inspect and deburr h. Attempt to break between hands i. Check thread path j. See instruction manual k. Spool off and throw thread beyond knot and re-thread.
Upper Thread Loops on Carpet Bottom	<ul style="list-style-type: none"> a. Upper thread not inserted properly in tension control b. Too little upper tension c. Dirty shuttle area d. Needle Height 	<ul style="list-style-type: none"> a. Check that out feed of tension control has drag on thread b. Check tension setting c. Clean shuttle d. See instruction manual
Upper Thread Tangles in Shuttle and/or in Cut on Carpet Bottom	<ul style="list-style-type: none"> a. Shuttle drive spring deformed or broken b. Binding on carpet with plastic backing (Unibond) c. Burrs on shuttle hook d. Binding carpet with backing where glue is not dry 	<ul style="list-style-type: none"> a. Replace drive spring b. Use lubricant c. Deburr hook d. Allow to dry and or use lubricant

Problem	Cause	Solution
Won't Pick Up Bobbin Thread	<ul style="list-style-type: none"> a. Needle height or clearance out of adjustment b. Bobbin tension incorrect c. Damaged bobbin tension spring d. Needle in wrong e. Too short of thread lead from bobbin case 	<ul style="list-style-type: none"> a. See instruction manual b. Check tension c. Replace spring d. Check needle e. Leave 2" of lead
Bobbin Thread Breaks	<ul style="list-style-type: none"> a. Bad bobbin b. Burr on shuttle hook or race cover or bad bobbin case spring 	<ul style="list-style-type: none"> a. Check thread strength b. Check each item
Stitch Misses Top or Bottom of Binding	<ul style="list-style-type: none"> a. Change in type of binding tape b. Cannot use cotton binding in polyester folder c. Carpet too thick d. Need to adjust folder position 	<ul style="list-style-type: none"> a. Check b. Check c. Bevel carpet d. See instruction manual
Bobbin Thread Loose on Bottom of Binding	<ul style="list-style-type: none"> a. Damaged or loose bobbin tension spring b. Dirt between bobbin tension spring & bobbin case 	<ul style="list-style-type: none"> a. Check spring b. Remove spring & clean surfaces
Bobbin Case Pops Out	<ul style="list-style-type: none"> a. Bobbin case not latched b. Latch spring broken c. Too wide needle clearance 	<ul style="list-style-type: none"> a. Check b. Check latch & spring c. Check adjustment
Carpet Curling	<ul style="list-style-type: none"> a. Binding tape too tight 	<ul style="list-style-type: none"> a. See Binding Tips

Binding Tips

Binding

- Straight stitch or zig zag is a matter of preference.
- The zig zag stitch is durable and more forgiving when trying to stay on the edge of the binding.
- With some types of backing the perforations of straight stitching can cause the edge to break, especially when using the heavy #23 needle.
- Straight stitching uses less thread which means bobbin thread goes farther. Straight stitching is great for wall base.
- Heavy carpets such as Berber are easier to bind with a straight stitch. The machine may skip stitches in zig zag.
- If the binding tape is uneven, (more on top than bottom or vice versa), perform the "Folder Adjustments" procedure (see Page 23).

Binding Corners

Binding corners requires some practice. A good way to learn is to cut 4 approximately 1' squares of carpet and bind them. You will gain a lot of experience by the time you reach corner #16.

Slowing the machine down with the speed control (included with Model #155 or optional #126-N with Model #126) will also aid in making corners, circles and curves.

If no speed control is used, trigger the machine in short bursts, but a speed control is much more effective.

A glue gun such as #103, #285 or #287 is necessary.

Feed roller pressure may be reduced to make turning the machine easier. When operating with less pressure, use care not to force the machine and deflect or break the needle. Feed roller height is changed by loosening the set screw in the lift dog (part #126 – 178).

Base Binding

If base starts to curl when binding, it is usually caused by tension on the binding tape. Check the discs to make sure they are not squeezing the tape. By-pass the tape guides on the folder and feed the tape directly into the folder. Dry teflon lubricant may be sprayed on both sides of tape spools.

Folder Adjustments

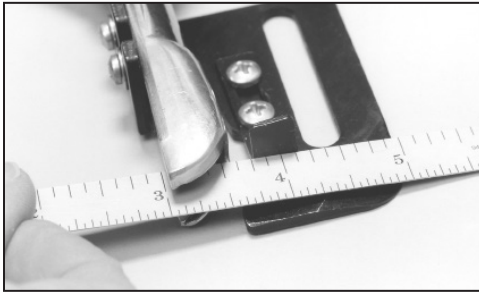

FIG. CC

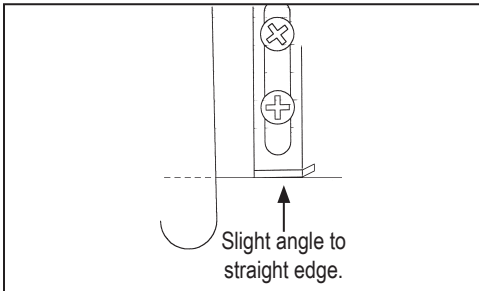

FIG. DD

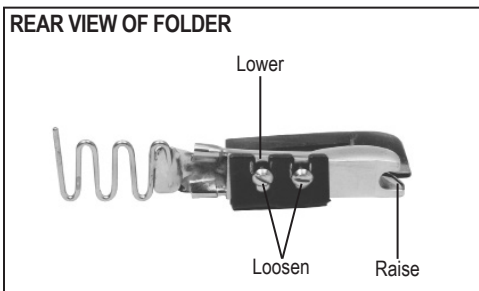

FIG. EE

Folder Adjustments

For uneven folds where the bottom stitch misses the tape there are 2 possible solutions.

1. Place a straight edge in the front of the folder (See Figure CC). Adjust the folder guide (part #126-1521) so that it just touches the straight edge and is at a slight angle away from the edge at the front. Trial and error maybe necessary with slightly more movement to the left (See Figure DD).
2. Loosen the folder to bracket screws. By trial and error movements of slight increments, raise the end where the binding tape comes out while keeping the screw at the opposite end at the bottom of the slot (See Figure EE).

Binding & Stitching Instructions**Normal Outside Corner**

1. Figure FF: Sew over end, then trim flush with edge.
2. Figure GG: Leave approximately 2-3" tail each time. Sew over trimmed end. Repeat on each corner.
3. Figure HH: When completed, fold and glue each corner.

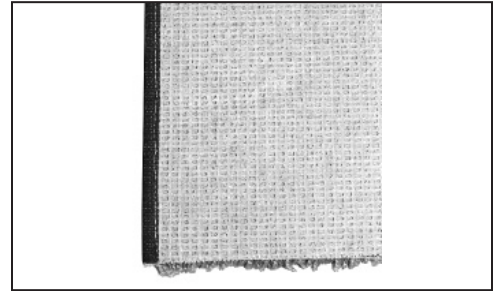
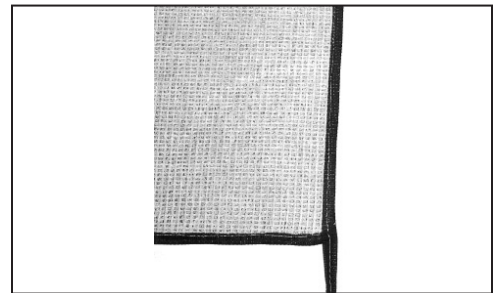
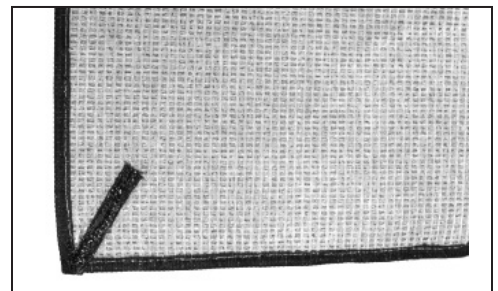
**FIG. FF****FIG. GG****FIG. HH**

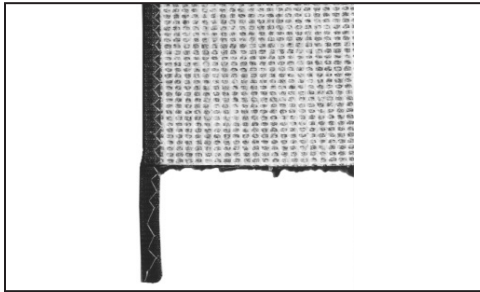

FIG. II

Optional — Double Covered Corners

1. Figure II: Sew over end leaving a 2" to 3" strip. Raise needle and cut.
2. Figure JJ: Fold tail under.
3. Figure KK: Place carpet in folder. Sew down that side. Repeat 1 through 3 on each corner.
4. Figure LL: When completed fold and glue all the strips down.

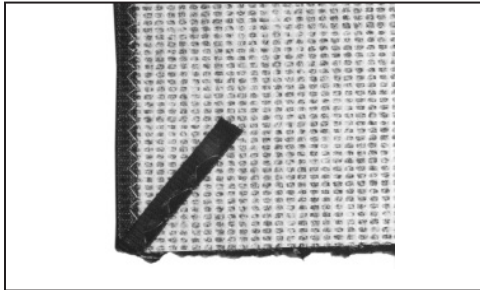

FIG. JJ

Sewn Corners

It is possible, but more difficult to sew around corners. Corners done in this manner are usually not as sharp as those done by folding over and gluing. You have to raise the feed roller, watch the needle, and move the carpet only when the needle is up. Zig zag should be used on corners. Straight stitching is not recommended. See Figure MM.

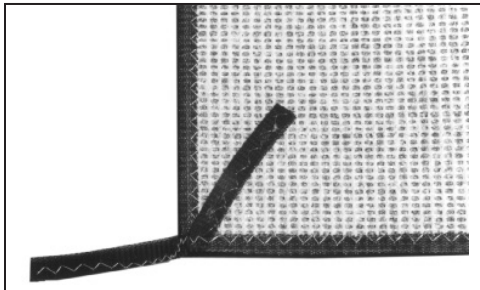

FIG. KK

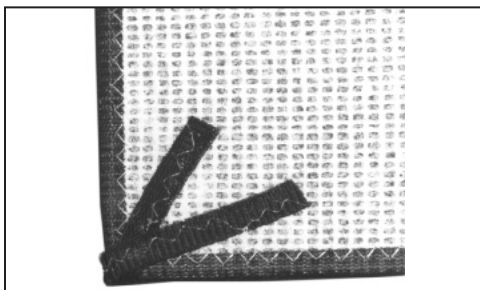

FIG. LL

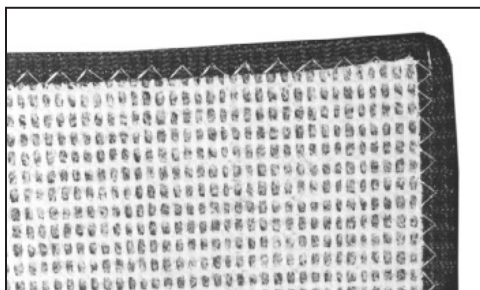

FIG. MM

Inside Corners

Inside corners may be done in two ways:

A. FIRST WAY

1. Figure NN: Cut the carpet back at the corner.
2. Figure OO: Fold back at cut and sew over end.
3. Figure PP: Fold back sewed side. Start at cut.
4. Figure QQ: Push fibers into cut. Use seam tape to close cut and glue back tails on tape.
5. Figure RR shows the top of the completed corner.

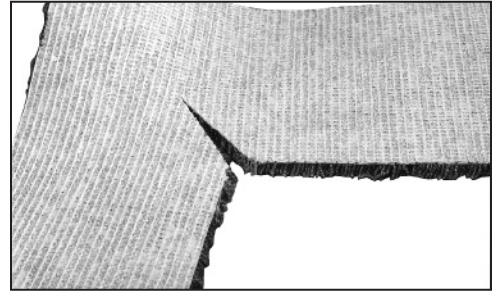

FIG. NN



FIG. OO

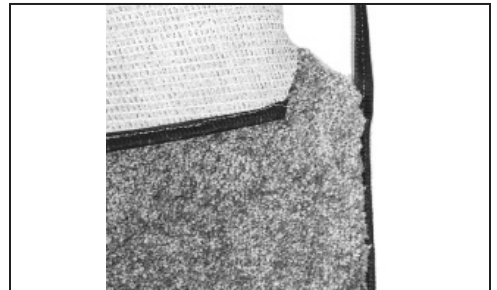

FIG. PP



FIG. QQ

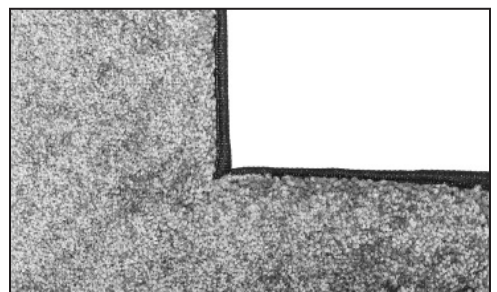

FIG. RR

Inside Corners (Cont'd)

B. SECOND WAY

Handsew or staple the corners as shown in Figure SS.

1. Allow enough binding to reach the corner when hand sewing.
2. Slide carpet in from back of machine and continue sewing.
3. Sew as close to the corner as machine will allow and stop.
4. Hand stitch the corner when done. Or, if stapling, staple tape (use 1-1/4" tape) on top edge of carpet and then fold over and glue on back of carpet. Note: If using tape, you must use 1-1/4" tape.

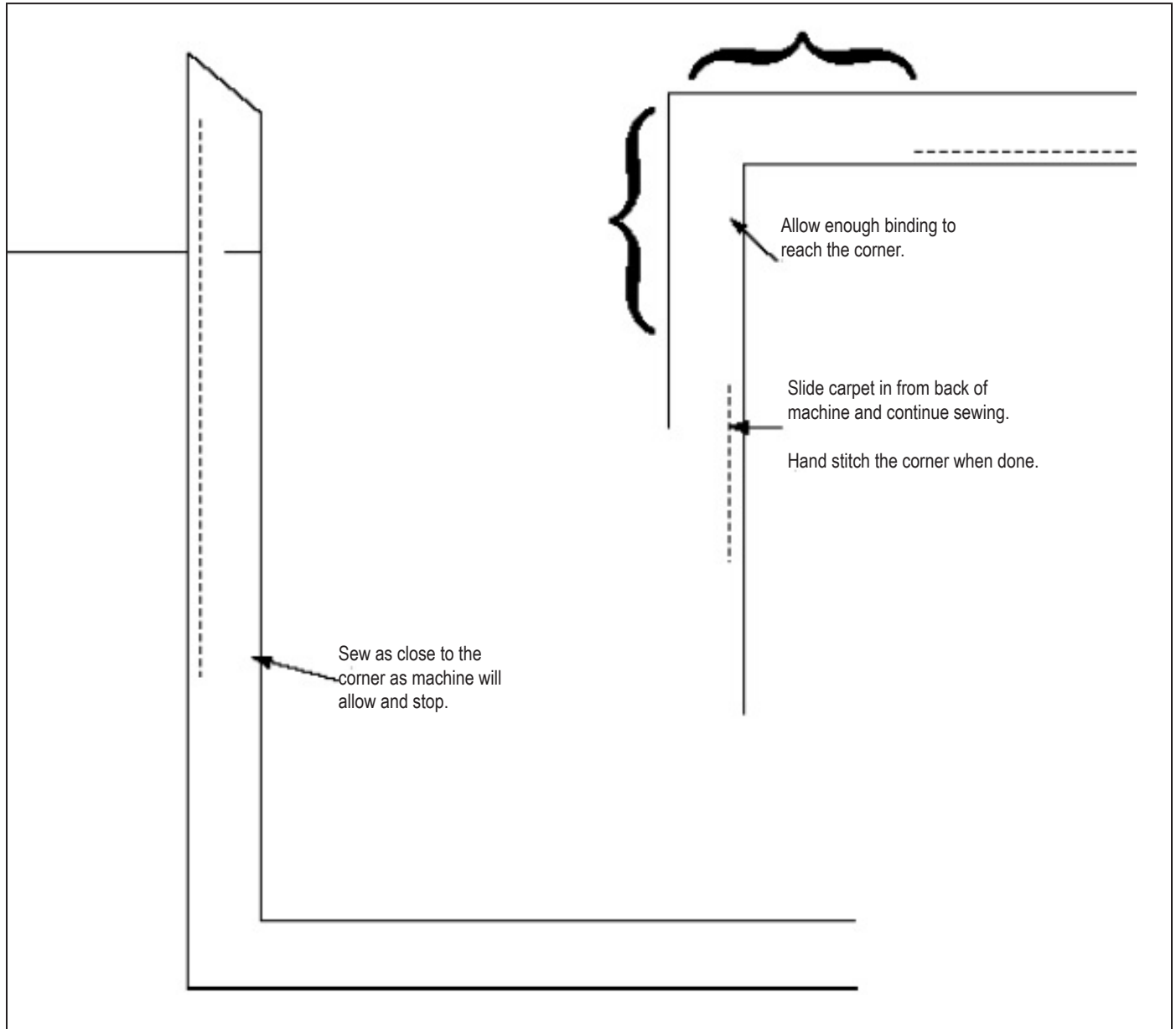

FIG. SS

Complete Parts List

Complete Parts List

PART#	DESCRIPTION	QTY	PART#	DESCRIPTION	QTY
126-02	COVER, END	1	126-18	CLAMP, THREAD TUBE	2
126-03-3	COVER, TOP	1	126-181	PIN, FEED ROLLER LIFT HANDLE	1
126-03G	ASSEMBLY, THREAD GUIDE	1	126-1821	KNOB, LIFT HANDLE	1
126-03H	HANDLE	1	126-19	TUBE, THREAD, UPPER	1
126-03HB	BOLT, SHOULDER, 10-24 X 5/8	2	126-19-1	TUBE, THREAD, LOWER	1
126-03HN	NUT, KEPS, 10-24	2	126-192	PULLEY, DRIVE MOTOR	1
126-03HW	WASHER, FENDER, 1/4 X 1-3/4	2	126-198	PLATE, MOUNTING, DRIVE MOTOR	1
126-04	SPINDLE, BINDING	1	126-199	BELT, DRIVE MOTOR	1
126-05	PLATE, BINDING SPINDLE	1	126-202	GUARD, BELT	1
126-07	NUT, BINDING SPINDLE	1	126-24-2	CONTROL, TENSION, UPPER THREAD	1
126-100	SHAFT, FLEX, DRIVE, WITH SCREWS	1	126-500	BULB, LIGHT, 120V, 15W, SCREW BASE	1
126-101A	SHAFT, FORWARD, FEED ROLLER	1	126-501	LIGHT KIT	1
126-102	ROLLER, FEED	1	126-501P	PLUG, LIGHT KIT	1
126-103	CAGE, FEED ROLLER	1	126-502A	RECEPTACLE, LIGHT, SNAP IN, BLACK	1
126-104	PLATE, GUIDE, ROLLER CAGE	1	126-502P	BRACKET, LIGHT	1
126-112-1	CASE, BOBBIN, WITH EYELET	1	126-52	RECEPTACLE, MOTOR POWER	1
126-113	HOOK, SHUTTLE	1	126-529	WHEEL, HAND	1
126-116	DRIVE, SHUTTLE	1	126-53	RETAINER, STRAIN RELIEF, POWER CORD	1
126-117	BODY, SHUTTLE	1	126-530	WASHER, RETAINING, HAND WHEEL	1
126-118	SHAFT, SHUTTLE DRIVE, 3/8"	1	126-531	RETAINER, HAND WHEEL	1
126-1192	SET, BEARINGS AND BOLT	1	126-532	PIN, SPRING .125 X .75	3
126-119T	CRANK, SHUTTLE DRIVE, FOR 3/8" SHAFT	1	126-533	SHAFT, TOP	1
126-12	CENTER, THREAD SPOOL	1	126-534	BEARING, FORWARD, TOP SHAFT	1
126-120	SHAFT, SHUTTLE OSCILLATOR	1	126-535	BUSHING, REAR, TOP SHAFT	1
126-122	ROD, CONNECTING, SHUTTLE DRIVE, WITH CAP AND SCREWS	1	126-536A	WASHER, 1/2" ID X 7/8" OD	1
126-124S	ASSEMBLY, SHUTTLE DRIVE, FORK, BEARING AND BOLT	1	126-537	GEAR, WORM, ZIGZAG DRIVE, 20 TOOTH	1
126-125	SPINDLE, LOWER, CONNECTING ROD	1	126-54	RELIEF, STRAIN	1
126-126	NUT, LOWER, CONNECTING ROD	1	126-540	SCREW, SET, 1/4-20 X 1/4"	2
126-128	CRANK, SHUTTLE OSCILLATOR, WITH SCREWS	1	126-542	ASSEMBLY, CAM, STITCH SELECTOR	1
126-13	SCREW, TOP COVER, REAR	1	126-544	ASSEMBLY, STITCH CONTROL	1
126-130	PIN, LINK, SHUTTLE OSCILLATOR	2	126-546	LINK, CONTROL, SHUTTLE OSCILLATOR, WITH SCREW	1
126-1302	E-CLIP, LINK PIN	2	126-550	BUSHING, CAM LINK, STITCH SELECTOR	1
126-131	LINK, SHUTTLE OSCILLATOR	1	126-551	SHOE, CAM, STITCH SELECTOR	1
126-134	BAR, GUIDE, SHUTTLE CLAMP	1	126-552	ROD, CONTROL, NEEDLE BAR CARRIER	1
126-136	COLLAR, SHUTTLE DRIVE SHAFT, WITH SET SCREWS	1	126-553	SCREW, SET, 8-32 X 1/8	1
126-139	CLAMP, SHUTTLE DRIVE	1	126-554	PIN, CONTROL ROD, NEEDLE BAR CARRIER	1
126-14	SCREW, TOP COVER, FRONT	1	126-561	CLAMP, WIRE, PAN	2
126-140B	COVER, RACE, WITH SPRING AND SCREWS	1	126-57	SWITCH, CONTROL, 100V/220V	1
126-144	GUIDE, LIFT SHAFT, FEED ROLLER	1	126-574	GEAR, WORM, ZIGZAG DRIVE, 20 TOOTH	1
126-145	SHAFT, LIFT, FEED ROLLER	1	126-600	PIN, LATCH	1
126-147	BALANCE, COUNTER, NEEDLE BAR DRIVE	1	126-90	ROD, CONNECTING, WITH CAP AND SCREWS	1
126-148	SCREW, MOUNTING, NEEDLE PLATE	1	126-92	CRANK, DRIVE, FEED ROLLER	1
126-149-1	PLATE, NEEDLE	1	126-96	BLOCK, ROLLER DRIVE, WITH BEARING	1
126-149-1A	PLATE, FILLER	1	126-97	SHAFT, MAIN, FEED ROLLER DRIVE	1
126-151	BRACKET, FOLDER	1	126-98	SPRING, RETAINING, FEED ROLLER	1
126-1521	GUIDE, FOLDER	1	126-A2	BOBBINS, HEAVY DUTY, NYLON, 72 YDS, SIZE D	0.013
126-154	FOLDER, BINDING, 7/8"	1	126-B2A	NEEDLE, SIZE 23, SCHMETZ, PK OF 10, INCLUDED W/BRUTES	0.1
126-156	CARRIER, NEEDLE BAR	1	126-C4T	STAND, THREAD	1
126-158	SPRING, NEEDLE BAR	1	126-CS	CENTER, 7/8", BINDING TAPE	1
126-160	ASSEMBLY, NEEDLE BAR DRIVE LINK	1	126-DISC	DISCS, SET	1
126-161	SCREW, NEEDLE BAR DRIVE LINK	1	126-E	THREAD, TOP, NYLON, (SPOOL OF 4300 YARDS)	1
126-162	LINK, DRIVE, NEEDLE BAR	1	126-P217	KIT, TOOL, BINDING BRUTE	1
126-164	COLLAR, NEEDLE BAR DRIVE, WITH SET SCREW	1	126-P47B	BOX, BINDING BRUTE	1
126-165	PIN, NEEDLE BAR DRIVE LINK, WITH E-CLIP AND SET SCREW	1	126-P47FT	FOAM, TOP, BINDING BRUTE	1
126-167	SCREW, SPRING, LOWER ROLLER PLATE	2	155-526-1	PAN, BINDING BRUTE (155)	1
126-168	SPRING, LOWER ROLLER PLATE	2	155-527	SCREW, THUMB, KNURLED KNOB, BLACK, 10-24 X .75	3
126-169	ROLLER, LOWER	1	155-528	WASHER, SWITCH	1
126-170	PIN, LOWER ROLLER	1	155-537	WHEEL, PAN, LARGE	4
126-171	PLATE, LOWER ROLLER	1	155-572-1	RETAINER, STAINLESS STEEL, GROOVELESS, 1/8"	2
126-172	ASSEMBLY, NEEDLE BAR AND PRESSER FOOT	1	155-573	SCREW, REAR, NEEDLE PLATE	2
126-177	BUSHING, LIFT SHAFT, FEED ROLLER	1	155-575	BAR, RETAINER, NEEDLE PLATE	1
126-178	LIFT DOG, FEED ROLLER, WITH SET SCREW	1	155-636	CAM, DRIVE, FEED ROLLER	1
126-179	SPRING, FEED ROLLER, LIFT SHAFT	1			

Complete Parts List

126 SINGLE-PULL BINDER

PART#	DESCRIPTION	QTY	PART#	DESCRIPTION	QTY
155-782	HANDLE, LIFT, FEED ROLLER	1	73351	WASHER, FLAT, 5/16, SAE	1
155-P47FB	FOAM, BOTTOM, BINDING BRUTE	1	73353	BOLT, HD SHOULDER SOC 5/16X5/8	4
2045	OILER, BRUTE	1	74402	SCREW, CUP POINT SET 10-32X3/8	2
401412	SCREW, 8-32 X 1/2 PPH-MS	6	74404	SCREW, SOCKET HEAD CAP 10-32X5/8	5
401496	SCREW, 1/4-20 X 3/8 HHCS	2	74406	SCREW, PHILLIPS PAN HEAD 10-32X3/8	4
401499	FRAME, BINDER UPPER	1	74408	SCREW, CUP POINT SOCKET SET 10-32X1/8	1
402360	SCREW, SET, 8-32 X 1/4, BLACK	2	74414	WASHER, FLAT SAE #10	9
402362	WASHER, FLAT #8, ZINC	4	74425	NUT, KEPS LOCK 10-32	1
402363	WASHER, HEAVY DUTY, 1/4, YELLOW ZINC	2	74427	SCREW, PHILLIPS PAN HEAD MACHINE 10-32X3/4	1
500-12	CORD, POWER, MOLDED 5-15P PLUG, 19'	1	74433	SCREW, PHILLIPS PAN HEAD 10-32X1/2	3
71021	BEARING, 1/8" ID, B24	2	74437	SCREW, CUP POINT 10-32X1/4	3
71051	BEARING, WHEEL, 5/16" ID, B56	4	74440	SCREW, SOCKET HEAD CAP 10-32X3/4	2
71081	BEARING, 5/8"ID, RCB101416	2	74501	WASHER, #6 FLAT SAE	2
72301	MOTOR, DRIVE, 115V	1	74507	SCREW, PHILLIPS PAN HEAD 6-32X1/4	1
72569	WIRE, PRIMARY, 14 GPT-500-BLK (TSC)	5	74550	SCREW, PHILLIPS PAN HEAD MACHINE 6-40X3/8	9
72768	TERMINAL, 12-10 GAUGE, NYLON C, 10	1	74565	NUT, KEPS 8-32	6
72778	TERMINAL, 16-14 GAUGE, NYLON, B RING	4	74569	SCREW, CUP POINT SOCKET SET SCREW8-32X3/16	2
72879	TUBE, SHRINK, BLACK, 1-1/2", 100' ROLL	5	74570	SCREW, PHILLIPS PAN HEAD 8-32X3/16	2
72885	TUBE, SHRINK, 1", BLACK	0.5	78-432	TAPE, BINDING 7/8" (2 ROLLS PER PKG)	1
72942	TERMINAL, CB-646	1	80101	CAP, END	1
73002	WASHER, SPLIT LOCK 1/4	2	L04	LABEL, BINDING BRUTE	1
73009	NUT, FULL HEX 1/4-20	4	L06	LABEL, STITCH	1
73012	SCREW, SET, 1/4-20 X 3/8	4	L09	LABEL, BINDING BRUTE	1
73041	WASHER, FLAT, USS, 1/4	12	L130	LABEL, BRUTE BOX	1
73064	SCREW, CUP POINT SET 1/4-20X3/4	3	L14	LABEL, NATIONAL, GOLD	1
73085	NUT, FLANGE, ZINC, 1/4-20	1	L146	LABEL, REPAIR	1
73098	SCREW, SLOTTED FILLISTER HEAD MACHINE 1/4-20X1-1/2	2	L222	LABEL, 'ASSEMBLED IN USA'	1
73263	WASHER, FLAT SEA ZINC 3/8	1	L29	LABEL, BASIC OPERATING INSTRUCTIONS	1
73306	BOLT, HEX HEAD CAP 5/16-18X1/2	1	L48	LABEL, THREADING INSTRUCTION	1
73346	BOLT, SHOULDER 5/16X1/2	1			

Accessories

PART#	DESCRIPTION	PART#	DESCRIPTION
126-A1	NYLON BOBBINS, STYLE A, SIZE O, 125 YARDS	126-N	SPEED CONTROL, 110V, 15 AMP
126-A2	NYLON BOBBINS, STYLE A, SIZE D, 72 YARDS, HEAVY DUTY	126-NW	SPEED CONTROL, 220V, 20 AMP
126-A3	NYLON BOBBINS, STYLE F, 80 YARDS, CARDBOARD SIDES	126-P217	ACCESSORY KIT
126-B1	SCHMETZ 140/22, 100/PKG	171	BASE ATTACHMENT FOR 126 SINGLE PULL BINDING BRUTE
126-B1A	SCHMETZ 140/22, 10/PKG	421	REPLACEMENT BATTERY <i>ONLY</i>
126-B2	SCHMETZ 160/23, 100/PKG, HEAVY DUTY	422	REPLACEMENT CHARGER <i>ONLY</i> , 110V
126-B2A	SCHMETZ 160/23, 10/PKG, HEAVY DUTY	422-W	REPLACEMENT CHARGER <i>ONLY</i> , 220V
126-E	NYLON BINDING THREAD	680	4" THREAD CLIP
126-H	FOOT PEDAL <i>ONLY</i> , 110V	1840	TWEEZERS
126-HW	FOOT PEDAL <i>ONLY</i> , 220V	1841	SMALL SCREWDRIVER SET

Attachments

PART#	DESCRIPTION	PART#	DESCRIPTION
126-C1	COTTON FOLDER 3/4"	126-C7	4-3/4" FOLDER
126-C2	2-3/4" WIDE BINDER FOLDER	126-CF	7/8" BINDING/SERGING FOLDER
126-C3	2" FOLDER	126-D	1-1/4" RAW EDGE FOLDER
126-C4	3" FOLDER	126-D1	1-1/4" SINGLE TUCK
126-C41	3" SINGLE TUCK FOLDER	126-D3	1-1/4" WIDE GAP RAW EDGE FOLDER

THIS PAGE INTENTIONALLY BLANK

Parts List and Diagrams

#126-03-1 Round Zig Zag Control

OLD STYLE



#126-03-2 Zig Zag Lever in Middle of Machine

OLD STYLE

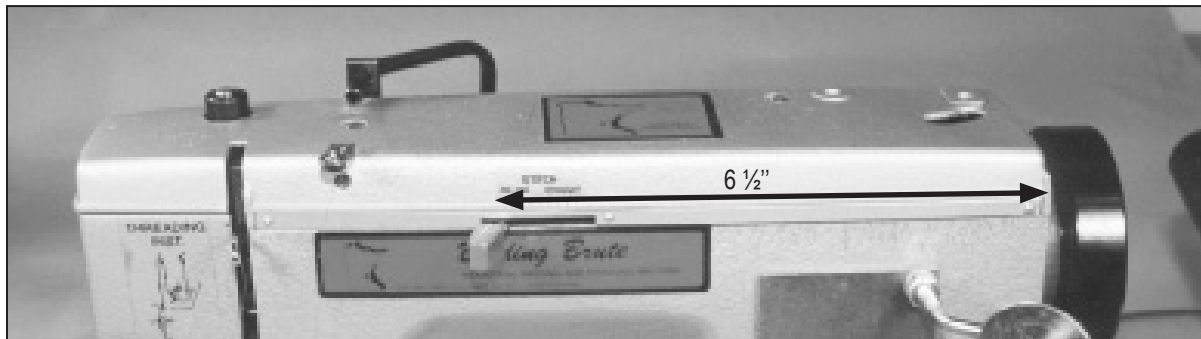

#126-03-3 Zig Zag Lever behind Binding Tape Disks

CURRENT STYLE

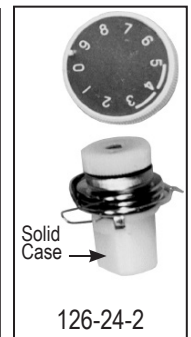
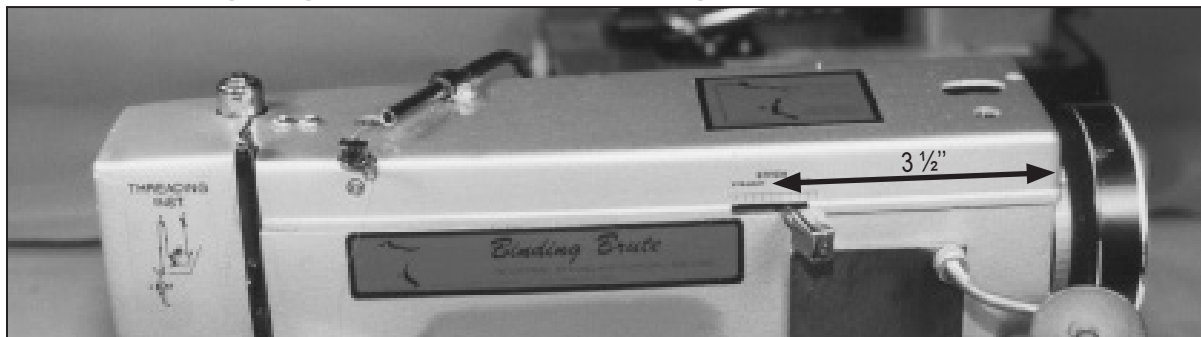

Bobbin Case

This machine uses bobbin case with an eyelet: Part #126-112-1.

Thread must pass through eyelet in bobbin case for proper operation. Tension on the bobbin thread should be light.

You have a #23 needle in the machine, when ordering needle ask for size #23.

(126-B2A [10 pk], 126-B2 [100 pk])

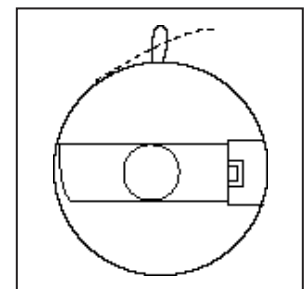

Frame Parts

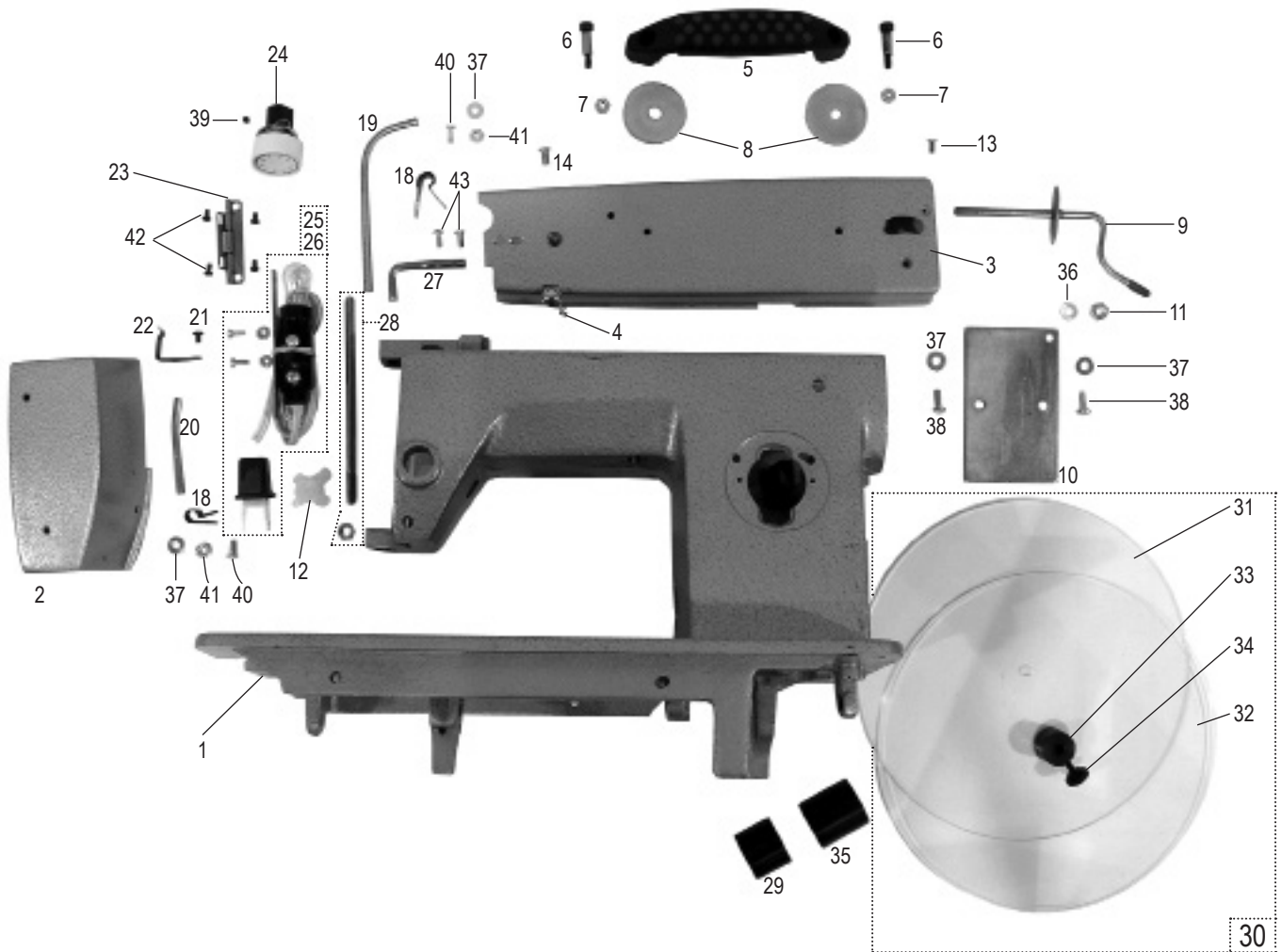

PART#	DESCRIPTION	QTY	PART#	DESCRIPTION	QTY
1	401499 FRAME	1	25	126-500 BULB ONLY, 15W, 120V, SMALL THREADED BASE	1
2	126-02 END COVER	1	26	126-501 LIGHT KIT	1
3	126-03-3 TOP COVER	1	27	126-600 LATCH PIN (FOR COVER)	1
4	126-03G TOP COVER GUIDE ASSEMBLY	1	28	126-C4T THREAD STAND BOLT & NUT	1
5	126-03H HANDLE ONLY	1	29	126-CS TAPE CENTERING PLUG FOR 7/8" TAPE	1
6	126-03HB HANDLE BOLT, 10-24 X 5/8" SHOULDER BOLT	2	30	126-DISC BINDING DISC SET (INCLUDES DISC 1, DISC 2, DISC COLLAR & THUMB SCREW)	1
7	126-03HN HANDLE NUT	2	31	126-DISC1 REAR DISC	1
8	126-03HW HANDLE FENDER WASHER	2	32	126-DISC2 FRONT DISC WITH COLLAR & THUMB SCREW	1
9	126-04 BINDING SPINDLE	1	33	126-DISC2A DISC COLLAR	1
10	126-05 BINDING SPINDLE PLATE	1	34	126-DISC2B DISC COLLAR THUMB SCREW	1
11	126-07 BINDING SPINDLE NUT	1	35	126-DS TAPE CENTERING PLUG FOR 1-1/4" TAPE	1
12	126-12 THREAD SPOOL CENTER	1	36	73002 1/4 SPLIT LOCK WASHER	1
13	126-13 TOP COVER REAR SCREW	1	37	74414 #10 FLAT WASHER SAE	2
14	126-14 TOP COVER FRONT SCREW	1	38	74433 10-32 X 1/2 PHILLIPS PAN HEAD SCREW	2
15	N/A NOT USED	-	39	74437 10-32 X 1/4 SET SCREW	1
16	401412 UPPER AND LOWER THREAD TUBE SCREW (NOT SHOWN)	2	40	74510 6-32 X 3/8 PHILLIPS PAN HEAD MACHINE SCREW	2
17	74565 UPPER AND LOWER THREAD TUBE NUT (NOT SHOWN)	2	41	74518 6-32 HEX NUT W/TOOTH WASHER (KEPS NUT)	2
18	126-18 THREAD TUBE CLAMP	2	42	74550 6-40 X 3/8 PHILLIPS PAN HEAD MACHINE SCREW	4
19	126-19 UPPER THREAD TUBE	1	43	401412 LATCH PIN SCREW	2
20	126-19-1 LOWER THREAD TUBE	1	44	74568 #8 EXTERNAL LOCK WASHER (NOT SHOWN)	1
21	126-20 FRONT COVER LATCH SCREW	1	45	126-502P LIGHT BRACKET (NOT SHOWN)	1
22	126-21 FRONT COVER LATCH	1	46	74565 LATCH PIN NUT (NOT SHOWN)	2
23	126-23 FRONT COVER HINGE	1			
24	126-24-2 UPPER THREAD TENSION CONTROL	1			

NOTE: See complete parts list for hardware descriptions.

Pan Parts

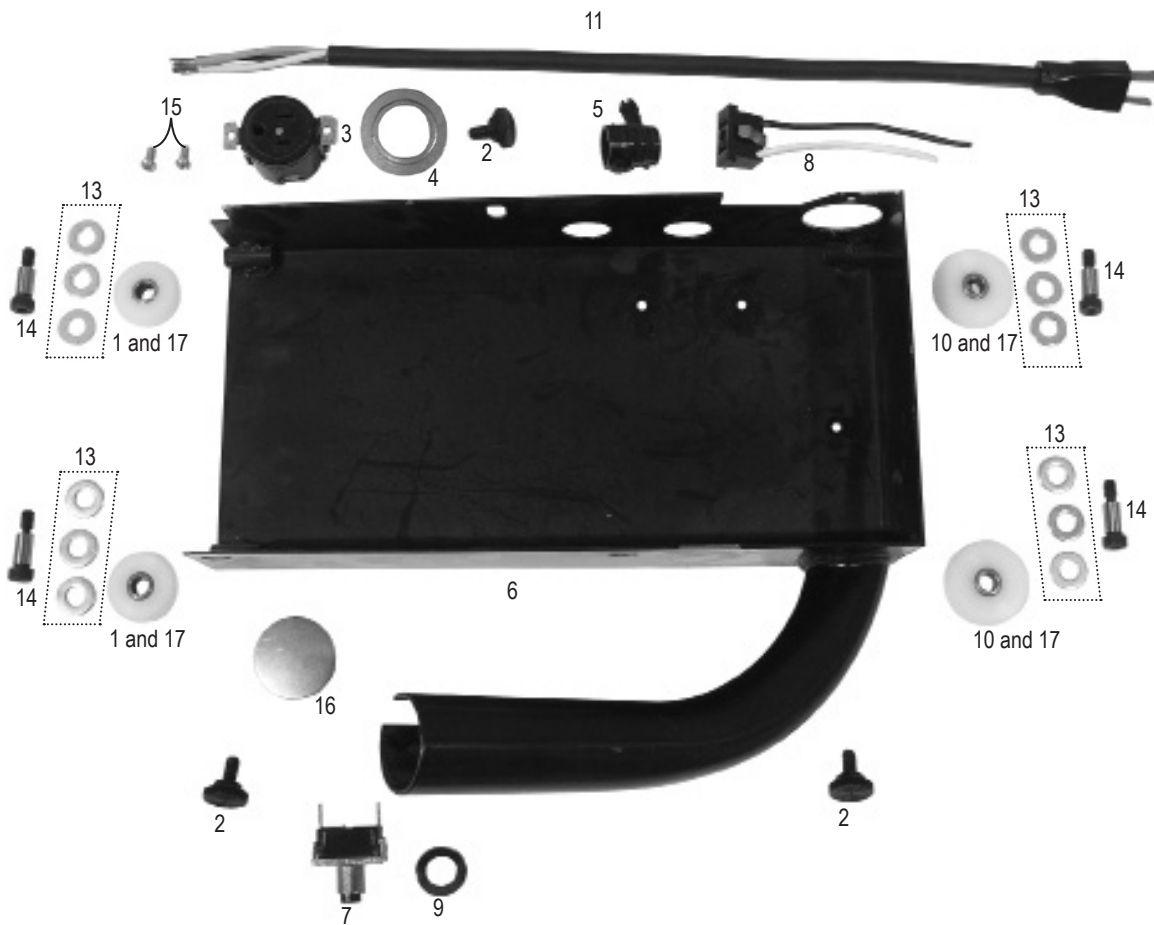

PART#	DESCRIPTION	QTY	PART#	DESCRIPTION	QTY
1	126-49* FRONT PAN WHEEL	2	13	73041 PAN WHEEL SPACER	12
2	126-50* PAN MOUNTING THUMB SCREW	3	14	73353 5/16 X 5/8 SOCKET HEAD SHOULDER BOLT	4
3	126-52 MOTOR POWER RECEPTACLE	1	15	74567 MOTOR POWER RECEPTACLE SCREW	2
4	126-53 POWER CORD STRAIN RELIEF RETAINER	1	16	80101 PAN HANDLE CAP	1
5	126-54 POWER CORD STRAIN RELIEF	1	17	71021 PAN WHEEL BEARING	4
6	126-56* PAN ONLY	1	18	72878 HANDLE SHRINK TUBE (NOT SHOWN)	1
7	126-57 CONTROL SWITCH ASSEMBLY	1	19	155-527 PAN MOUNTING THUMB (NOT SHOWN)	3
8	126-502A LIGHT RECEPT. - SNAP IN	1	20	72778 GROUND WIRE CONNECTOR (NOT SHOWN)	1
9	155-528 SWITCH WASHER	1	21	72768 TERMINAL CONNECTOR (NOT SHOWN)	1
10	155-537 PAN WHEEL ONLY	4	22	72942 TERMINAL CONNECTOR (NOT SHOWN)	1
11	500-12 POWER CORD	1	23	74406 WIRE SECURING SCREW (NOT SHOWN)	2
12	155-526-1 PAN ONLY (NOT SHOWN)	1	24	74565 WIRE SECURING LOCK NUT (NOT SHOWN)	2

NOTES:

1. Asterisk (*) indicates parts that were used on older machines.
2. See complete parts list for hardware descriptions.

Drive Motor Parts

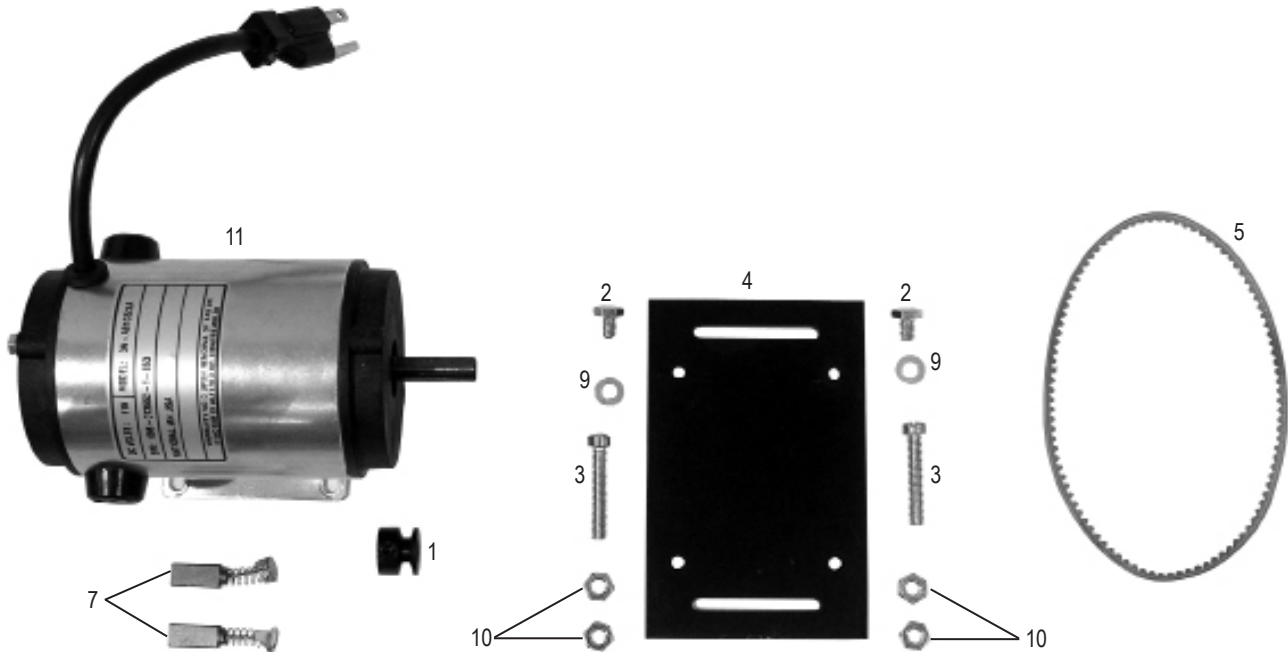

PART#	DESCRIPTION	QTY	PART#	DESCRIPTION	QTY
1	126-192 DRIVE MOTOR PULLEY	1	13	72311W DRIVE MOTOR 230V (NOT SHOWN)	1
2	401496 1/4-20 X 3/8 DRIVE MOTOR LOWER MOUNT SCREW	2	14	126-31* LOWER DRIVE BELT, SMALL, 110 X L037G (NOT SHOWN)	1
3	401497 1/4-20 X 1 1/2 DRIVE MOTOR UPPER MOUNT SCREW	2	15	126-32* UPPER DRIVE BELT, LARGE, RIBBED (NOT SHOWN)	1
4	126-198 DRIVE MOTOR MOUNTING PLATE	1	16	126-202 BELT GUARD (NOT SHOWN)	1
5	126-199 DRIVE MOTOR BELT	1	17	73306 BELT GUARD BOLT (NOT SHOWN)	1
6	126-1910* DRIVE MOTOR 110V BRUSHES (NOT SHOWN)	2	18	73351 BELT GUARD WASHER (NOT SHOWN)	1
7	126-1910A DRIVE MOTOR 110V BRUSHES	2	19	74433 BACK BELT GUARD SCREW (NOT SHOWN)	1
8	126-1910B DRIVE MOTOR 230V BRUSHES (NOT SHOWN)	1	20	74014 BACK BELT GUARD WASHER (NOT SHOWN)	1
9	73002 1/4 SPLIT LOCK WASHER	2	21	74404 PLATE MOUNTING SCREW (NOT SHOWN)	2
10	73009 1/4-20 FULL HEX NUT	4	22	74414 PLATE MOUNTING WASHER (NOT SHOWN)	2
11	72301 DRIVE MOTOR 115V	1			
12	73039 DRIVE MOTOR PULLEY SET SCREW 1/4-20 X 3/16 CUP POINT SOCKET SET SCREW (NOT SHOWN)	1			

NOTES:

1. Asterisk (*) indicates parts that were used on older machines.
2. See complete parts list for hardware descriptions.

Needle Plate Parts

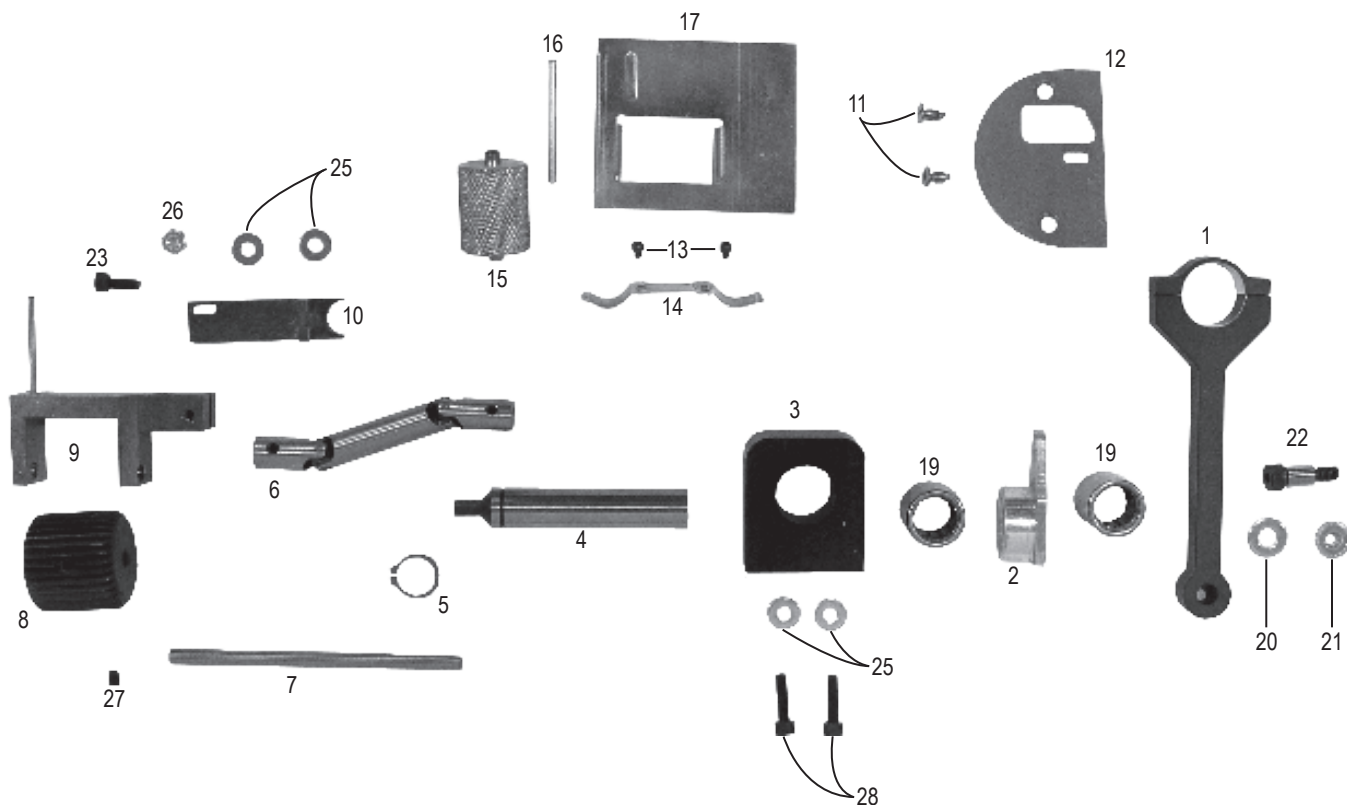

PART#	DESCRIPTION	QTY	PART#	DESCRIPTION	QTY		
1	126-90	CONNECTING ROD W/CAP & SCREWS	1	19	71081	5/6" ID BEARING	2
2	126-92	FEED ROLLER DRIVE CRANK	1	20	73007	CONNECTING ROD LOWER SPINDLE SPACER	1
3	126-96	FEED ROLLER DRIVE BEARING BLOCK	1	21	73085	CONNECTING ROD SPINDLE FLANGE NUT	1
4	126-97	FEED ROLLER DRIVE MAIN SHAFT	1	22	73346	CONNECTING ROD SPINDLE	1
5	126-98	FEED ROLLER DRIVE SHAFT RETAINING SPRING	1	23	74405	FEED ROLLER CAGE GUIDE PLATE MOUNTING SCREW	1
6	126-100	FEED ROLLER DRIVE FLEX SHAFT WITH SCREWS	1	24	74408	REPL. FEED ROLLER DRIVE FLEX SHAFT SET SCREW ONLY NOT SHOWN	2
7	126-101A	FEED ROLLER FORWARD SHAFT	1	25	74414	FEED ROLLER DRIVE BEARING BLOCK FLAT WASHER	4
8	126-102	FEED ROLLER	1	26	74425	FEED ROLLER CAGE GUIDE PLATE JAMB NUT	1
9	126-103	FEED ROLLER CAGE	1	27	74402	FEED ROLLER SET SCREW	1
10	126-104	FEED ROLLER CAGE GUIDE PLATE	1	28	74440	FEED ROLLER DRIVE BEARING BLOCK SCREW	2
11	126-148	NEEDLE PLATE MOUNT SCREW	2	29	74562	REPL. CONNECTING ROD CAP SCREW ONLY (NOT SHOWN)	2
12	126-149*	NEEDLE PLATE	1	30	126-149-1	NEEDLE FILLER PLATE (NOT SHOWN)	1
13	126-167	LOWER ROLLER PLATE SPRING SCREW	2	31	126-169	LOWER ROLLER (NOT SHOWN)	1
14	126-168	LOWER ROLLER PLATE SPRING	1	32	155-572-1	RETAINERS, 1/8" FOR LOWER ROLLER PIN (NOT SHOWN)	2
15	401819	LOWER ROLLER W/BEARINGS	1	33	155-573	FILLER PLATE SCREWS (NOT SHOWN)	2
16	126-170	LOWER ROLLER PIN	1	34	155-575	NEEDLE RETAINER BAR (NOT SHOWN)	1
17	126-171	LOWER ROLLER PLATE	1	35	74501	ROLLER PLATE SPRING WASHER (NOT SHOWN)	2
18	71021	BEARING ONLY FOR LOWER ROLLER (NOT SHOWN)	1				

NOTES:

1. Asterisk (*) indicates parts that were used on older machines.
2. See complete parts list for hardware descriptions.

Internal Parts

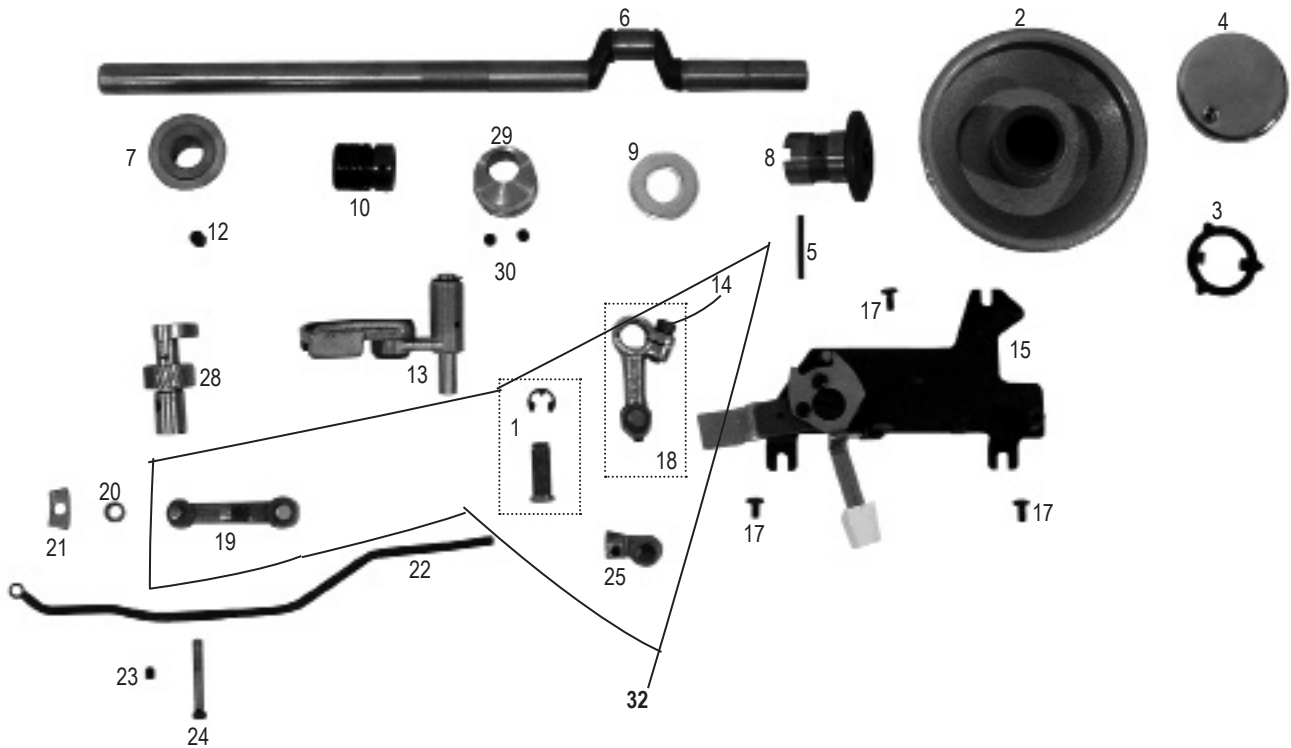

PART#	DESCRIPTION	QTY	PART#	DESCRIPTION	QTY
1	126-528 LINK PIN W/ RETAINER CLIP	1	17	74550 STITCH CONTROL ASSEMBLY MOUNTING SCREW	3
2	126-529 HAND WHEEL	1	18	126-546 SHUTTLE OSCILLATOR CONTROL LINK W/ SCREW	1
3	126-530 HAND WHEEL RETAINER WASHER	1	19	126-549 STITCH SELECTOR CAM LINK	1
4	126-531 HAND WHEEL RETAINER	1	20	126-550 STITCH SELECTOR CAM LINK BUSHING	1
5	126-532 TOP SHAFT BEARING RETAINER PIN	1	21	126-551 STITCH SELECTOR CAM SHOE	1
6	126-533 TOP SHAFT	1	22	126-552 NEEDLE BAR CARRIER CONTROL ROD	1
7	126-534 TOP SHAFT FORWARD BEARING	1	23	126-553 NEEDLE BAR CARRIER CONTROL ROD SET SCREW	1
8	126-535 TOP SHAFT REAR BUSHING	1	24	126-554 NEEDLE BAR CARRIER CONTROL ROD PIN	1
9	126-536A DRIVER CAM WASHER	1	25	126-555 NEEDLE BAR CARRIER CONTROL ROD SOCKET W/SCREW	1
10	126-537 ZIG ZAG DRIVE GEAR W/ SCREWS	1	26	126-556 REPL. NEEDLE BAR CARRIER CONTROL ROD LOCK SCREW ONLY (NOT SHOWN)	1
11	126-538 REPL. STITCH SEL. CAM CLAMPING SCREW ONLY (NOT SHOWN)	1	27	-	-
12	126-540 TOP SHAFT FORWARD BEARING SET SCREW	1	28	126-574 ZIG ZAG DRIVE WORM GEAR	1
13	126-542 STITCH SELECTOR CAM ASSEMBLY	1	29	155-636 FEED ROLLER DRIVE CAM	1
14	126-543 REPL. SHUTTLE OSCILLATOR CONTROL LINK CLAMPING SCREW ONLY	1	30	74437 FEED ROLLER DR. CAM SET SCREW	2
15	126-544 STITCH CONTROL ASSEMBLY	1	31	73012 STITCH SELECTOR CAM ASSY SET SCREW (NOT SHOWN)	1
16	N/A NOT USED	-			

NOTE: See complete parts list for hardware descriptions.

PART#	DESCRIPTION	QTY
32	401494 SHUTTLE OSCILLATOR LINKAGE ASSEMBLY	1
>126-528	LINK PIN W/ RETAINER CLIP	1
>126-546	SHUTTLE OSCILLATOR CONTROL LINK W/ SCREW	1
>126-549	STITCH SELECTOR CAM LINK	1
>126-555	REPL. NEEDLE BAR CARRIER CONTROL ROD LOCK SCREW ONLY (NOT SHOWN)	1

Internal Parts (Cont'd)

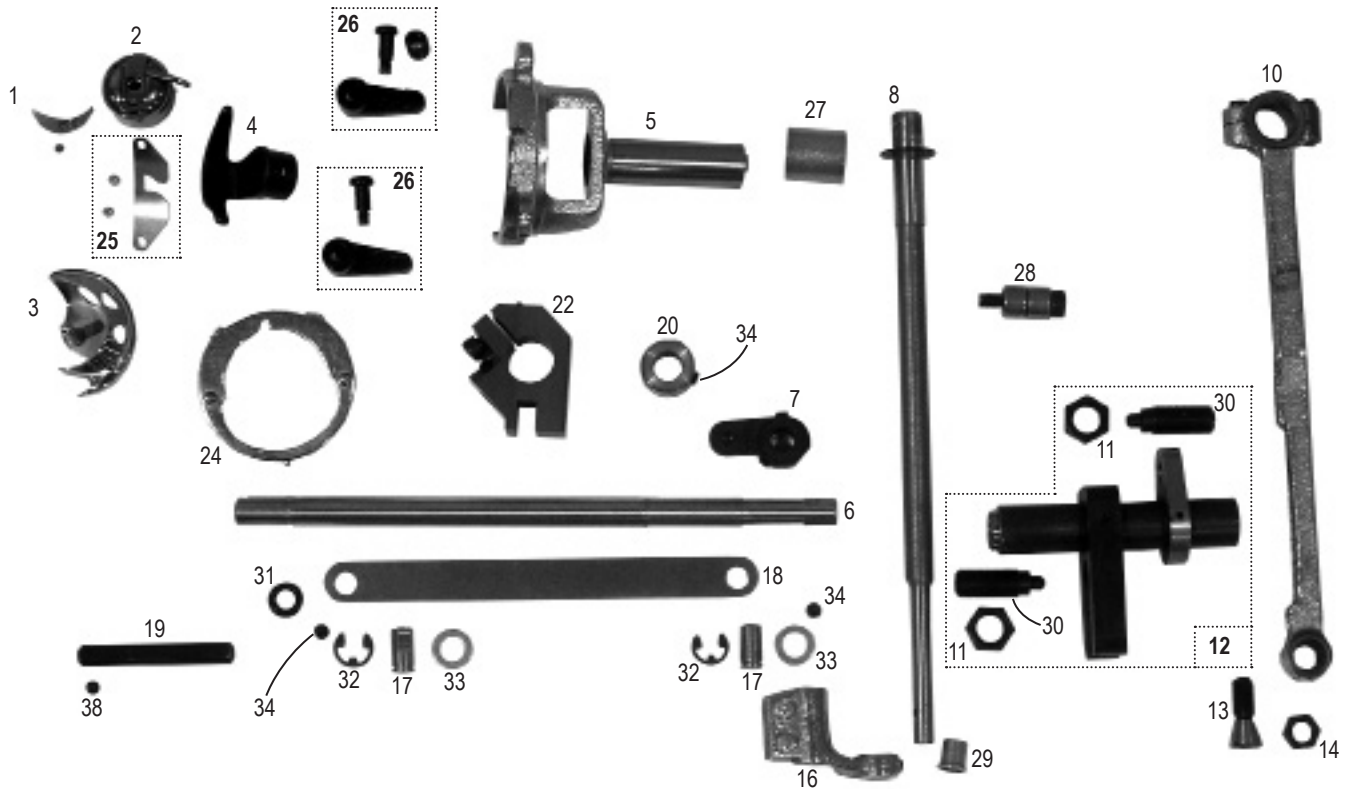

PART#	DESCRIPTION	QTY	PART#	DESCRIPTION	QTY
1	— NOT USED (NO LONGER AVAILABLE)	—	24	126-140B SHUTTLE RACE COVER W/ SPRINGS & SCREWS (NO RED)	1
2	126-112-1 BOBBIN CASE W/EYELET	1	25	126-142 SHUTTLE RACE COVER SPRING W/SCREWS	1
3	126-113 SHUTTLE HOOK	1	26	126-1171 RACE COVER RETAINERS	2
4	126-116 SHUTTLE DRIVE	1	27	126-1172 SHUTTLE BODY BUSHING	1
5	126-117 SHUTTLE BODY W/RACE COVER RETAINERS	1	28	126-1192 BEARINGS AND BOLT SET	1
6	126-118 SHUTTLE DRIVE SHAFT 3/8"	1	29	126-1201 SHUTTLE OSCILLATOR SHAFT BUSHING	1
7	126-119T SHUTTLE DRIVE CRANK W/SET SCREWS (FOR 3/8" SHAFT)	1	30	126-1242 DRIVE FORK BOLT	2
8	126-120 SHUTTLE OSCILLATOR SHAFT	1	31	126-1301 O-RING FOR LINK PIN	1
9	-	-	32	126-1302 E-CLIP FOR LINK PIN	1
10	126-122 SHUTTLE DRIVE CONNECTING ROD W/ CAP & SCREWS	1	33	126-1303 WASHER FOR LINK PIN	2
11	126-123 DRIVE FORK RETAINER	2	34	74409 SHUTTLE DRIVE SHAFT COLLAR SET SCREW ONLY	2
12	126-124S SHUTTLE DRIVE FORK, BEARING & BOLT ASSY.	1	35	74409 SHUTTLE OSCILLATOR LINK SET SCREW (NOT SHOWN)	2
13	126-125 CONNECTING ROD LOWER SPINDLE	1	36	74409* SHUTTLE DRIVE CRANK SET SCREWS ONLY (NOT SHOWN). [FOR 119N & 119T]	2
14	126-126 CONNECTING ROD LOWER SPINDLE NUT	1	37	75569 SHUTTLE DRIVE CLAMP SET SCREW ONLY (NOT SHOWN)	1
15	-	-	38	74569 SHUTTLE CLAMP GUIDE BAR SET SCREW	1
16	126-128 SHUTTLE OSCILLATOR CRANK W/ SCREWS	1	39	126-114* SHUTTLE DRIVE SCREWS FOR 115 SPRING (NOT SHOWN)	2
17	126-130 SHUTTLE OSCILLATOR LINK PIN	2	40	126-115* SHUTTLE DRIVE SPRING FOR SHUTTLE DRIVER (NOT SHOWN)	1
18	126-131 SHUTTLE OSCILLATOR LINK	1	41	126-118N* SHUTTLE DRIVE SHAFT 5/16" (NOT SHOWN)	1
19	126-134 SHUTTLE CLAMP GUIDE BAR	1	42	126-119N* SHUTTLE DRIVE CRANK FOR 5/16" SHAFT (NOT SHOWN)	1
20	126-136 SHUTTLE DRIVE SHAFT COLLAR W/ SET SCREWS FITS 3/8"	1	43	74404 SHUTTLE DRIVE CLAMP BOLT (NOT SHOWN)	1
21	74404 SHUTTLE DRIVE CLAMP LOCK SCREW ONLY (NOT SHOWN)	1	44	73263 SHUTTLE DRIVE OSCILLATOR SHAFT WASHER (NOT SHOWN)	1
22	126-139 SHUTTLE DRIVE CLAMP W/ SCREWS	1			
23	126-140A* SHUTTLE RACE COVER W/ SPRINGS & SCREWS (RED)	1			

NOTES: 1) Asterisk (*) indicates parts that were used on older machines. 2) See complete parts list for hardware descriptions.

Internal Parts (Cont'd)

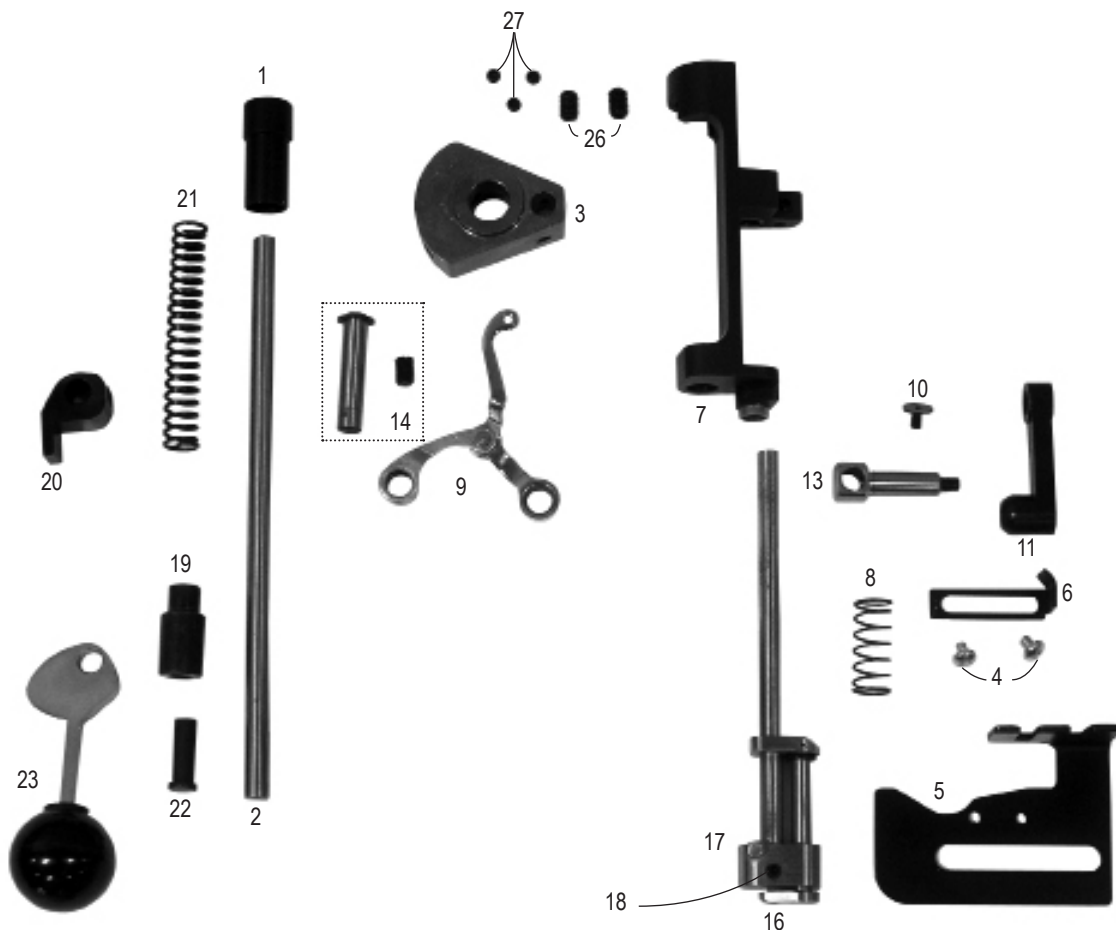

PART#	DESCRIPTION	QTY	PART#	DESCRIPTION	QTY
1	126-144 FEED ROLLER LIFT SHAFT RETAINER	1	18	74569 NEEDLE SET SCREW	1
2	126-145 FEED ROLLER LIFT SHAFT	1	19	126-177 FEED ROLLER LIFT SHAFT BUSHING	1
3	126-147 NEEDLE BAR DRIVE COUNTER BALANCE	1	20	126-178 FEED ROLLER LIFT DOG W/ SET SCREW	1
4	74570 FOLDER GUIDE MOUNT SCREW (NOT SHOWN)	2	21	126-179 FEED ROLLER LIFT SHAFT RETURN SPRING	1
5	126-151 FOLDER BRACKET	1	22	126-181 FEED ROLLER LIFT HANDLE PIN	1
6	126-152 FOLDER GUIDE	1	23	126-182 FEED ROLLER LIFT HANDLE	1
7	126-156 NEEDLE BAR CARRIER	1	24	73012 1/4-20 X 3/8 CUP POINT SOCKET SET SCREW (NOT SHOWN)	1
8	126-158 NEEDLE BAR SPRING	1	25	74414 WASHER, FOLDER BRACKET #10 (NOT SHOWN)	2
9	126-160 NEEDLE BAR DRIVE LINKAGE ASSEMBLY W/DRIVE ARM	1	26	73064 1/4-20 X 3/4 CUP POINT SOCKET SET SCREW	3
10	126-161 NEEDLE BAR DRIVE LINK RETAINER	1	27	74408 10-32 X 1/8 CUP POINT SOCKET SET SCREW	4
11	126-162 NEEDLE BAR DRIVE LINK	1	28	74404 SCREW, FOLDER BRACKET 10-32 SHCS (NOT SHOWN)	2
12	126-163 NEEDLE BAR SET SCREW (NOT SHOWN)	1	29	74402 DRIVE COLLAR SET SCREW (NOT SHOWN)	1
13	126-164 NEEDLE BAR DRIVE COLLAR W/ SET SCREW	1	30	74425 FEED ROLLER LIFT NUT (NOT SHOWN)	1
14	126-165 NEEDLE BAR DRIVE LINKAGE ASSEMBLY PIN W/ E-CLIP & SET SCREW	1	31	74427 FEED ROLLER LIFT SCREW (NOT SHOWN)	1
15	126-166 NEEDLE BAR DRIVE LINKAGE ASSEMBLY PIN E-CLIP (NOT SHOWN)	1	32	74550 FOLDER MOUNTING SCREW (NOT SHOWN)	2
16	126-172 NEEDLE BAR/PRESSER FOOT ASSEMBLY W/ SET SCREW	1	33	402362 FOLDER MOUNTING WASHER (NOT SHOWN)	2
17	126-172A NEEDLE BAR THREAD GUIDE	1			

NOTE: See complete parts list for hardware descriptions.

Accessories & Attachments

THREAD

#126E Clear Thread

- 4,300 yards per spool • Size #52
- Comes with sock
- For Binding Brutes, 8090, 8093

#126EH Clear Heavy Duty Thread

- 3,500 yards per spool • Size #63
- Comes with sock
- For Binding Brutes, 8090, 8093

#2045 Lubricant

Brute oiler, 1 ounce, with extendable spout.

Bobbins

We use the best nylon not polyester.

- Tackified so they won't overspin in the bobbin case
- Sideless
- 80 spools per pkg.
- #126-A1 Style-A, Size O • 125 yards • Nylon
- #126-A2 Style-A, Size D • 72 yards • Nylon • Heavy Duty
- #126-A3 Style-F, Size ASP • 80 yards. For use with Binders other than National's



Needles

We use the strongest needles in the world. Schmetz HD Cutting Point will run smoother and last longer than any other needle.

- #126-B1 140/22 100/pkg
- #126-B1A 140/22 10/pkg
- #126-B2 160/23 Heavy duty – ideal for tough carpet 100/pkg
- #126-B2A 160/23 10/pkg (supplied with Brute)

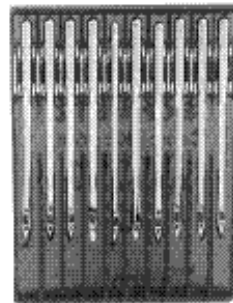

Speed Control #126-N

Proper speed improves control of machine.

- #126-N Speed Control 110v, 15 amp



Battery and Charger

#421 Replacement Battery Only

#422 Replacement Charger Only 110v

For use with "cordless" machines #1126, #1155, #8089 & #8094

Battery and Charger



Base Attachments

#170 Base Attachment for #155 Double Pull Binding Brute

#171 Base Attachment for #126 Single Pull Binding Brute

- Easily attaches to Binding Brutes
- Adjustable for various base widths
- Makes it a hands-free operation
- Adjusts from 2-1/2" to 6"

Base Attachments

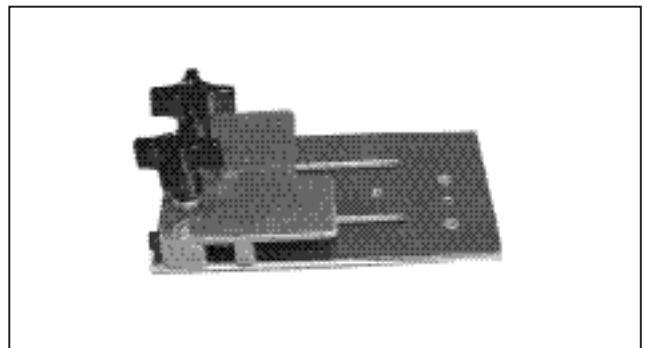

#126-P217 Accessory Kit

Includes eight bobbins, ten needles, four screwdrivers, thread clip, tweezers, four allen wrenches, and case.

Accessory Kit



Tweezers, Screwdriver, Thread Clip

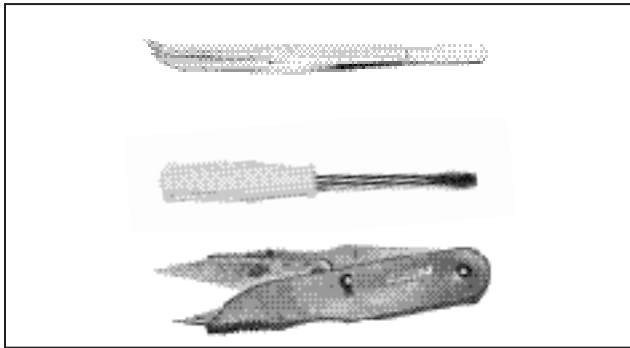

#1840 Tweezers

- Deluxe bent 6" tweezers • Comes with accessory kit

#1841 Small Screwdriver Set

- Contains two small screwdrivers with plastic handles
- Comes with accessory kit

#680 Thread Clip

- Value priced
- Full length 4"
- Length of cut 1"
- Comes with accessory kit

Binding and Serging Attachments

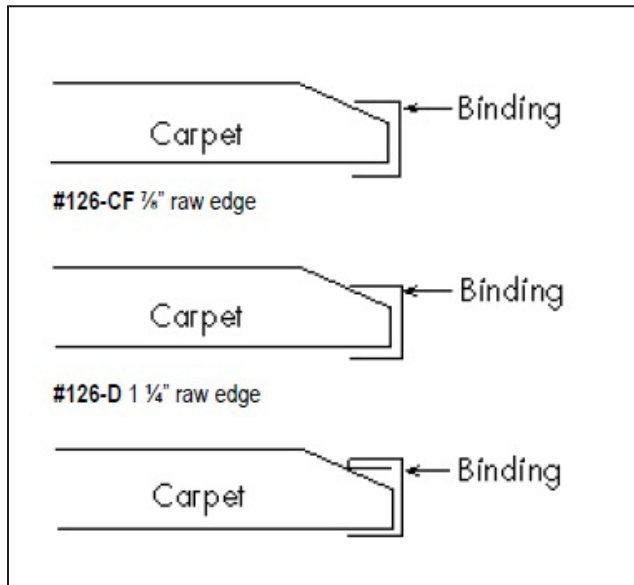

Binding and Serging Attachments

- #126-C1 3/4" Cotton Folder
- #126-C2 2 3/4" Wide Binding Folder
- #126-C3 2" Folder
- #126-C4 3" Folder
- #126-C41 3" Single Tuck Folder
- #126-C7 4-3/4" Folder
- #126-CF 7/8" Binding/Serging Folder
- #126-D 1 1/4" Raw Edge Folder
- #126-D1 1 1/4" Single Tuck
- #126-D3 1 1/4" Wide Gap Raw Edge Folder (Great for heavy Berber or thick unbeveled carpet)

Folders are made for National binders; modifications may be required to fit other brand machines. Custom folders available; please call to inquire.



Assembled Machine Pictures

Top View

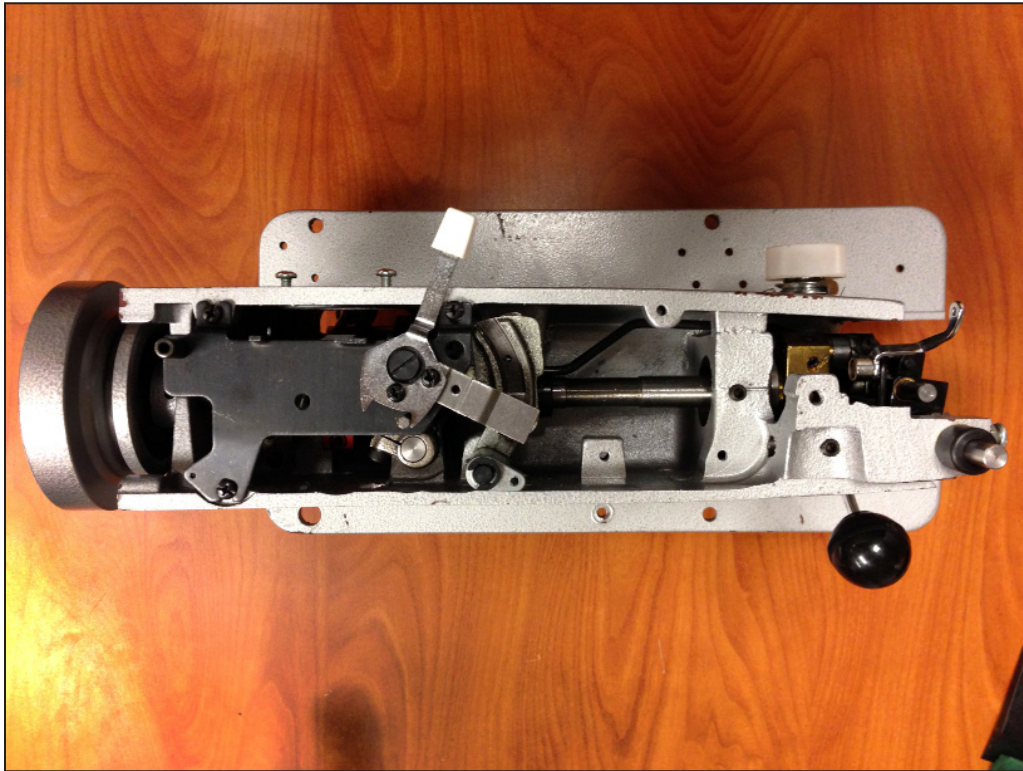

Bottom View

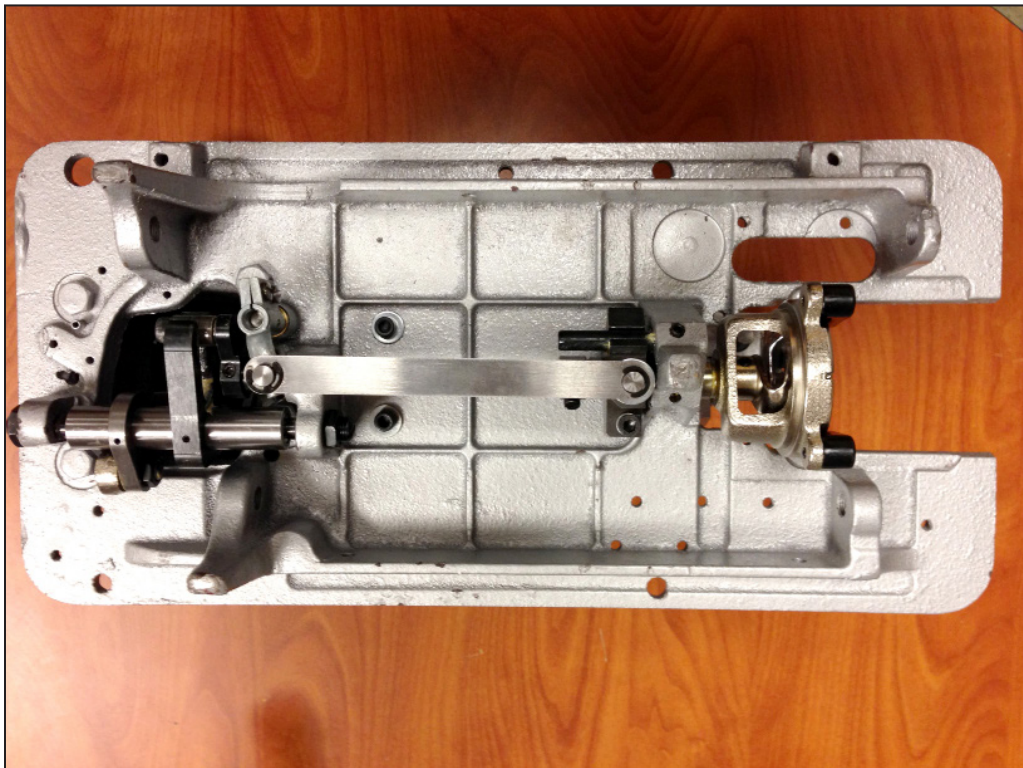

End View

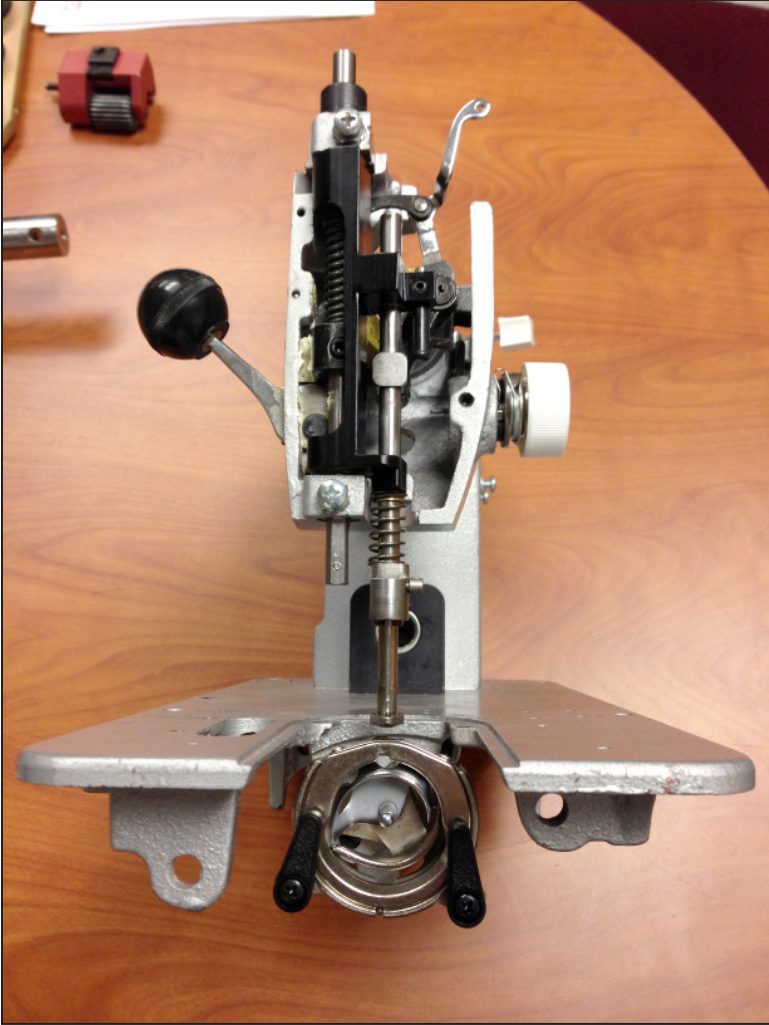

Warranty

National Flooring Equipment Inc. (referred to as "the Company") warrants that each new unit manufactured by The Company, to be free from defects in material and workmanship in normal use and service for a period of 90 days from date of shipment from the Company. Accessories or equipment furnished and installed on the product by the Company but manufactured by others, including but not limited to: engines, motors, electrical components, transmissions etc., shall carry the accessory manufacturers own warranty. Battery warranties are prorated over the warranty period. Customer is responsible for the inspection of equipment / parts upon delivery. Freight damages reported beyond authorized time frame will not be honored.

The Company, at its determination of defect, will repair or replace any product or part deemed to be defective in material or workmanship within specified warranty time period. All product determinations and / or repairs will take place at the designated Company repair facility, or at a certified warranty location designated by the Company. The Company will coordinate and be responsible for all freight expenses associated with valid warranty claims. Freight and shipping expenses associated with abuse or misuse will be back charged to the Distributor/Customer. The Company reserves the right to modify, alter or improve any part / parts without incurring any obligation to replace any part / parts previously sold without such modified, altered or improved part / parts. In no event shall the seller or manufacturer of the product be liable for special, incidental, or consequential damages, including loss of profits, whether or not caused by or resulting from the negligence of seller and / or the manufacturer of the product unless specifically provided herein. This warranty shall not apply to any products or portions there of which have been subjected to abuse, misuse, improper installation or operation, lack of recommended maintenance, electrical failure or abnormal conditions and to products which have been tampered with, altered, modified, repaired, reworked by anyone not approved or authorized by the Company or used in any manner inconsistent with the provisions of the above or any instructions or specifications provided with or for the product. Any and all unauthorized onsite warranty work conducted by unauthorized personnel or any outside person(s), is not covered by the Company unless the work has been pre-authorized by a predetermined manufacturer representative. This excludes wearable parts and/or consumables.

Defective or failed material or equipment shall be held at the purchaser's premises until authorization has been granted by the Company to return or dispose of defective products. Products returned for final inspection must be returned with a manufacturer authorized Return Material Authorization (RMA). Any unauthorized return of equipment will be declined at the dock by the Company. Any non-approved items returned with approved returned items are subject to rejection and will not be credited. Credit will be issued for material found to be defective upon the Company's inspection based on prices at time of purchase.

To obtain a Material Safety Data Sheet and/or a copy of the CE Declaration of Conformity please contact National. This product is CE compliant.

TO OBTAIN SERVICE CONTACT NATIONAL FLOORING EQUIPMENT, INC. TOLL FREE AT 800-245-0267 FOR A REPAIR AUTHORIZATION NUMBER. COD FREIGHT RETURNS WILL NOT BE ACCEPTED. FREIGHT COLLECT SHIPMENTS WILL NOT BE ACCEPTED. WARRANTY REPAIRS MUST BE ACCOMPANIED BY DATE OF PURCHASE RECEIPT AND A RETURN/REPAIR AUTHORIZATION NUMBER.

RETURN/REPAIR AUTHORIZATION NUMBER: _____

MACHINE SERIAL NUMBER: _____

THIS PAGE INTENTIONALLY BLANK



Made in America Since 1968

9250 Xylon Avenue N • Minneapolis, MN 55445 • U.S.A.
Toll-free 800-245-0267 • Phone 763-315-5300 • Fax 800-648-7124 • Fax 763-535-8255
Web Site: www.nationalequipment.com • E-Mail: info@nationalequipment.com