

3432 HANDHELD POLISHER

INSTRUCTION MANUAL



Read Manual Before Operating Machine

Table of Contents

Features and Specifications	4
Safety	5
Components and Assembly	7
Assembly	7
Velcro Adapter for Polishing Discs.....	7
Vacuum Port	7
Handles.....	7
Safety Switch and Lock	7
Assemble and Remove Wheel/Disk	7
Operation	8
Machine Start-Up Procedure	8
Maintenance	9
General Maintenance	9
Motor Cleaning	9
Warranty	10

Features and Specifications



Your choice of National Floor Equipment 5" polishing discs can be mounted to the Velcro-backed polishing pad adapter for polishing operations.

FEATURES

Polyurethane Convertible Dust Shroud - Allows machine to work all the way to the edge.

Loop Handle - Provides a comfortable, secure grip for working in confined spaces.

Vacuum Dust Port - Allows machine to work in conjunction with dust collectors; offers a more comfortable work environment while reducing jobsite cleanup.

Variable Speed - Located on the underside of the polisher.

Product Specifications

Length	Weight	Disk Size	Input Power	Amps	RPM
19" (48.26 cm)	10 lb (4.5 kg)	5" (13 cm)	120V / 60Hz	10	700-2,200

GENERAL RULES FOR SAFE OPERATION

Before use, anyone operating or performing maintenance on this equipment must read and understand this manual, as well as any labels packaged with or attached to the machine and its components. Read the manual carefully to learn equipment applications and limitations, as well as potential hazards associated with this type of equipment. Keep manual near machine at all times. If your manual is lost or damaged, contact National Flooring Equipment (NFE) for a replacement.

Personal

Dress properly and use safety gear.

Do not wear loose clothing; it may be caught in moving parts. Anyone in the work area must wear safety goggles or glasses, hearing protection during extended use, and a dust mask for dusty operations. Hard hats, face shields, safety shoes, etc. should be worn when specified or necessary.

Maintain control; stay alert.

Keep proper footing and balance, and maintain a firm grip. Observe surroundings at all times and use common sense. Do not use when tired, distracted, or under the influence of drugs, alcohol, or any medication that may cause decreased control.

Keep hands away from all moving parts and tooling.

Wear gloves when changing tooling. Remove tooling when machine is not in use and/or lower cutting head to the floor.

Do not force equipment.

Equipment will perform best at the rate for which it was designed. Excessive force only causes operator fatigue, increased wear, and reduced control.

Environment

Avoid use in dangerous environments.

Do not use in rain, damp or wet locations, or in the presence of explosive atmospheres (gaseous fumes, dust, or flammable materials). Remove materials or debris that may be ignited by sparks. Keep work area tidy and well-lit - a cluttered or dark work area may lead to accidents. Extreme heat or cold may affect performance.

Protect others in the work area and be aware of surroundings.

Provide barriers or shields as needed to protect others from debris and machine operation. Children and other bystanders should be kept at a safe distance from the work area to avoid distracting the operator and/or coming into contact with the machine. Operator should be aware of who is around them and their proximity. Support personnel should never stand next to, in front of, or behind the machine while the machine is running. Operator should look behind them before backing up.

Guard against electric shock.

Ensure that machine is connected to a properly grounded outlet. Prevent bodily contact with grounded surfaces, e.g. pipes, radiators, ranges, and refrigerators. When scoring or making cuts, always check the work area for hidden wires or pipes.

Maintenance & Repairs

Begin maintenance work only when the machine is shut down, unplugged, and cooled down.

Use proper cleaning agents.

Ensure that all cleaning rags are fiber-free; do not use any aggressive cleaning products.

Schedule regular maintenance check-ups.

Ensure machine is properly cleaned and serviced. Remove all traces of oil, combustible fuel, or cleaning fluids from the machine and its connections and fittings. Retighten all loose fittings found during maintenance and repair work. Loose or damaged parts should be replaced immediately; use only NFE parts.

Do not weld or flame-cut on the machine during repairs, or make changes to machine without authorization from NFE.

Equipment

Use proper parts and accessories.

Only use NFE-approved or recommended parts and accessories. Using any that are not recommended may be hazardous.

Ensure accessories are properly installed and maintained.

Do not permanently remove a guard or other safety device when installing an accessory or attachment.

Inspect for damaged parts.

Check for misalignment, binding of moving parts, loose fasteners, improper mounting, broken parts, and any other conditions that may affect operation. If abnormal noise or vibration occurs, turn the machine off immediately. Do not use damaged equipment until repaired. Do not use if power switch does not turn machine on and off. For all repairs, insist on only identical NFE replacement parts.

Maintain equipment and labels.

Keep handles dry, clean, and free from oil and grease. Keep cutting edges sharp and clean. Follow instructions for lubricating and changing accessories. Motor and switches should be completely enclosed at all times with no exposed wiring. Inspect cord regularly. Labels carry important information; if unreadable or missing, contact NFE for a free replacement.

Avoid accidental starting; store idle equipment.

When not in use, ensure that the machine is unplugged; do not turn on before plugging in. Store in a dry, secured place. Remove tooling when storing, and keep away from children.



CAUTION! ENSURE PROPER USE OF EXTENSION CORDS. IF AMP DRAW IS HIGHER THAN SHOWN ON TABLE OR CORD IS LONGER THAN 50 FT, SEE AN ELECTRICIAN.

ASSUMPTIONS: 3% ALLOWABLE VOLTAGE DROP, COPPER CONDUCTORS RATED FOR 75°C, 1.25 SAFETY FACTOR, CORD VOLTAGE RATING OF 600VAC, PROPER CORD TYPES (STO, STOW, SOOW).

Amp Draw	Gauge
0-12	14
13-16	12
14-24	10
25-40	8

Safety

HANDHELD SAFETY GUIDELINES

Before use, anyone operating this equipment must read and understand these safety instructions.

Grinding and Polishing

Beware of hidden obtrusions.

Watch out for hidden dangers and protrusions in flooring. Do not use on largely uneven surfaces.

Avoid contact with hot tooling and shroud.

Do not touch the tooling or shroud without proper hand protection. Both become hot during operation and remain hot after stopping the machine.

Use correct tooling and accessories.

Provide barriers or shields as needed to protect others from debris. After mounting tooling, rotate by hand to check for proper alignment.

Use for correct applications.

Do not force equipment to do heavier duty work than it was made for.

Blow compressed air through ventilation slots.

During use, conductive dust can form deposits inside the machine. This can mean a temporary danger of electric shock. When the machine is running, blow compressed air through the rear ventilation frequently and thoroughly. The machine must be held firmly while doing this.

Dust Collection

Use with appropriate dust collecting system.

Do not operate machine designed for use with a dust collector without the dust collector. Ensure dust collector is on and operating properly while grinding.

Use with appropriate dust collection hose.

Do not operate the machine without the hose securely attached to the inlet of the dust collector and the outlet of the grinder. In order to maintain system efficiency, do not use a damaged hose.

Dispose of collected waste.

Do not leave the dust collector bag full of waste. Handle and dispose of bag and waste in accordance with all applicable local, state, and federal regulations. Dispose of waste prior to transport.

Equipment

Use a Ground Fault Circuit Interrupter (GFCI).

Using a stationary extraction system with a Ground Fault Circuit Interrupter (GFCI) up or downstream is recommended. If the machine is deactivated by the GFCI, the machine must be checked and cleaned. If operating the equipment in damp locations is unavoidable, a GFCI must be used to supply the power. Electrician's rubber gloves and footwear will further enhance your personal safety.

Check for damaged wheels.

Carefully handle machine and wheels to avoid damage. Install a new wheel if machine is dropped during operation. Fragments from a wheel that burst during operation will fly away very quickly and dangerously, which could cause injury. Before operation, inspect the wheel for chips and cracks; remove bad wheels immediately. Run the tool at no load for one minute, holding the tool away from any people. Wheels with flaws will normally break apart during this time.

Always use handle and inspect regularly.

Use auxiliary handle for maximum control. A damaged or cracked side handle must be replaced immediately. Never operate a machine with a defective side handle.

Use proper accessories.

When using wheel attachments, the guard must always be attached and positioned so the least amount of wheel is exposed on the side that the machine is being operated. All accessories must have a maximum safe operation speed greater than the "no load RPM," which can be found on the machine's nameplate.



WARNING: GRINDING/CUTTING/DRILLING OF MASONRY, CONCRETE, METAL AND OTHER MATERIALS CAN GENERATE DUST, MISTS AND FUMES CONTAINING CHEMICALS KNOWN TO CAUSE SERIOUS FATAL INJURY OR ILLNESS, SUCH AS RESPIRATORY DISEASE, CANCER, BIRTH DEFECTS OR OTHER REPRODUCTIVE HARM. IF YOU ARE UNFAMILIAR WITH THE RISKS ASSOCIATED WITH THE PARTICULAR MATERIAL BEING CUT, REVIEW THE MATERIAL SAFETY DATA SHEET AND/OR CONSULT YOU EMPLOYER, THE MATERIAL MANUFACTURER/SUPPLIER, GOVERNMENTAL AGENCIES SUCH AS OSHA AND NIOSH AND OTHER AUTHORITIES ON HAZARDOUS MATERIALS. CALIFORNIA AND SOME OTHER AUTHORITIES, FOR INSTANCE, HAVE PUBLISHED LISTS OF SUBSTANCES KNOWN TO CAUSE CANCER, REPRODUCTIVE TOXICITY, OR OTHER HARMFUL EFFECTS. CONTROL DUST, MIST AND FUMES AT THE SOURCE WHERE POSSIBLE. IN THIS REGARD USE GOOD WORK PRACTICES AND FOLLOW THE RECOMMENDATIONS OF THE MANUFACTURER/SUPPLIER, OSHA/NIOSH, AND OCCUPATIONAL AND TRADE ASSOCIATIONS. WHEN THE HAZARDS FROM INHALATION OF DUST, MISTS AND FUMES CANNOT BE ELIMINATED, THE OPERATOR AND ANY BYSTANDERS SHOULD ALWAYS WEAR A RESPIRATOR APPROVED BY OSHA/MSHA FOR THE MATERIAL BEING CUT.

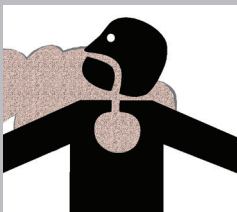

Components and Assembly

ASSEMBLY (FIGURE 1)

1. Place the dust shroud adapter over the arbor on the machine and line up the set screws with the mounting channel.
2. Slowly tighten the set screws on the adapter, while keeping the adapter centered about the arbor.
3. Lightly lubricate the dust shroud and slide it onto the adapter. Vacuum hose nozzle should be on the right side (from an operating standpoint). **Note:** Keep the clamp on the dust shroud.
4. Tighten the hose clamp while ensuring the nozzle doesn't interfere with the handle or mounting bolt. A minimum clearance of 1/4" is recommended.

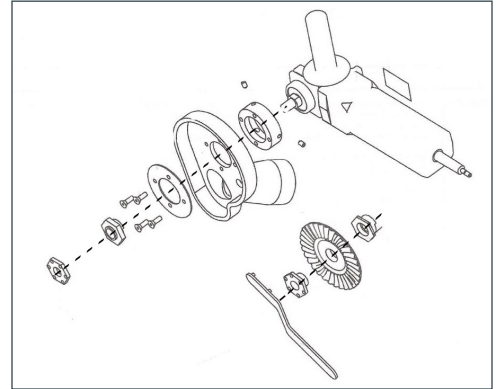

FIG. 1

VELCRO ADAPTER FOR POLISHING DISCS

To assemble, complete the following steps:

1. Twist the polishing pad adapter onto the threaded arbor until it bottoms out.
2. Press the spindle lock button and tighten the disc adapter.

To remove, press the spindle lock button and turn the disc adapter the opposite way.

VACUUM PORT

The vacuum port is attached to the shroud (Figure 2). Use a vacuum hose that snugly fits either on the outside or the inside of the port. The outside diameter of the port is 2"; the inside diameter is 1-3/4". This port will pick up dust but not all heavy or large particles.

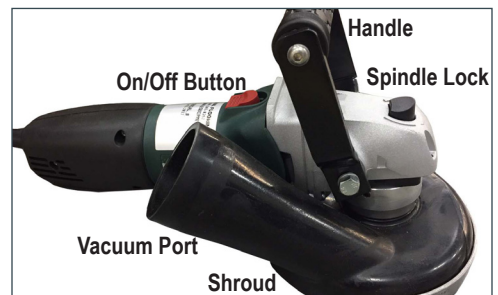

FIG. 2



WARNING: MAKE SURE YOU ARE USING THE PROPER STYLE OF VACUUM FOR WHAT YOU ARE GRINDING, SCRAPING OR SANDING. FAILURE TO DO SO COULD CAUSE EMISSIONS OF HAZARDOUS PARTICULATES OR EXPLOSION DUE TO FINE DUST (WOOD SANDING), WHICH IS FLAMMABLE. MAKE SURE THE SYSTEM YOU ARE USING COMPLIES OR EXCEEDS OSHA RECOMMENDED STANDARD. MAKE SURE THE RUBBER DUST GUARD IS COVERING ALL THE WAY TO THE FLOOR SURFACE.

HANDLES

There are two additional handle options: a single side handle and one that is connected on both sides of the machine (Figure 2). Always have one of these handles connected while using the machine. Handles are interchangeable and can be used or changed as needed. Both handles must be screwed in manually; with the largest side opposite the vacuum port. Unplug machine from power source before changing the handle.

SAFETY SWITCH AND LOCK

The machine is also equipped with a spindle locking device (Figure 2). Never turn on the machine while the spindle lock is engaged. Allow machine to come to a complete stop before engaging spindle lock.

ASSEMBLE AND REMOVE WHEEL/DISK

1. Press the spindle lock (Figure 2) to stop the spindle from rotating while tightening and loosening the blade nut.
2. Using the wrench provided or a 1-1/2" box wrench, remove the blade nut.

Operation



FIG. 3

MACHINE STARTUP PROCEDURE

1. Machine must be off before plugging into power source.
2. Plug power cord into proper size extension cord.
3. Plug extension cord into outlet.
4. Keep disk off the surface until the machine is on.
5. Depress red button on handle (Figure 3) for motor to run. The machine will run as long as the button is depressed.
6. Release button for motor to stop.
7. Once machine is running, gently lower disk to the surface. Guide machine with both hands.

GENERAL MAINTENANCE

A well-maintained machine is a productive machine. If not properly maintained, it could be unsafe or break down. Schedule regular maintenance check-ups to ensure efficient performance and a long life. The following maintenance should be performed by a NFE service center:

- Mechanical inspection and cleaning (pulleys, belts, bearings, nuts, bolts, housing, labels, etc.).
- Replacing worn or damaged parts (switches, guards, belts, etc.).
- Electrical inspection (switch, cord, plugs, etc.).
- Testing to assure proper mechanical and electrical operation.
- Replacing labeling.



WARNING: BEFORE PERFORMING ANY MAINTENANCE WORK, DISCONNECT THE TOOL FROM THE POWER SOURCE.



WARNING: NEVER DISASSEMBLE THE TOOL OR TRY TO DO ANY REWIRING ON THE TOOL'S ELECTRICAL SYSTEM. CONTACT NATIONAL FLOORING EQUIPMENT FOR ALL REPAIRS.



WARNING: TO REDUCE THE RISK OF INJURY, ELECTRIC SHOCK AND DAMAGE TO THE MACHINE, NEVER IMMERSE YOUR MACHINE IN LIQUID OR ALLOW A LIQUID TO FLOW INSIDE THE MACHINE.

MOTOR CLEANING

Blow compressed air through the rear ventilation sides of the machine thoroughly on a regular basis and frequently during usage. The machine must be held firmly while being cleaned.

Warranty

National Flooring Equipment Inc. (referred to as "the Company") warrants that each new unit manufactured by The Company, to be free from defects in material and workmanship in normal use and service for a period of twelve (12) months from date of shipment from the Company. For administrative ease, will honor warranty for a period of fifteen (15) months from date of shipment from the company. Accessories or equipment furnished and installed on the product by the Company but manufactured by others, including but not limited to: engines, motors, electrical components, transmissions etc., shall carry the accessory manufacturers own warranty. Battery warranties are prorated over the warranty period. Customer is responsible for the inspection of equipment / parts upon delivery. Freight damages reported beyond authorized time frame will not be honored.

The Company, at its determination of defect, will repair or replace any product or part deemed to be defective in material or workmanship within specified warranty time period. All product determinations and / or repairs will take place at the designated Company repair facility, or at a certified warranty location designated by the Company. The Company will coordinate and be responsible for all freight expenses associated with valid warranty claims. Freight and shipping expenses associated with abuse or misuse will be back charged to the Distributor/Customer. The Company reserves the right to modify, alter or improve any part / parts without incurring any obligation to replace any part / parts previously sold without such modified, altered or improved part / parts. In no event shall the seller or manufacturer of the product be liable for special, incidental, or consequential damages, including loss of profits, whether or not caused by or resulting from the negligence of seller and / or the manufacturer of the product unless specifically provided herein. This warranty shall not apply to any products or portions there of which have been subjected to abuse, misuse, improper installation or operation, lack of recommended maintenance, electrical failure or abnormal conditions and to products which have been tampered with, altered, modified, repaired, reworked by anyone not approved or authorized by the Company or used in any manner inconsistent with the provisions of the above or any instructions or specifications provided with or for the product. Any and all unauthorized onsite warranty work conducted by unauthorized personnel or any outside person(s), is not covered by the Company unless the work has been pre-authorized by a predetermined manufacturer representative. This excludes wearable parts and/or consumables.

Defective or failed material or equipment shall be held at the purchaser's premises until authorization has been granted by the Company to return or dispose of defective products. Products returned for final inspection must be returned with a manufacturer authorized Return Material Authorization (RMA). Any unauthorized return of equipment will be declined at the dock by the Company. Any non-approved items returned with approved returned items are subject to rejection and will not be credited. Credit will be issued for material found to be defective upon the Company's inspection based on prices at time of purchase.

TO OBTAIN SERVICE CONTACT NATIONAL FLOORING EQUIPMENT, INC. TOLL FREE AT 800-245-0267 FOR A REPAIR AUTHORIZATION NUMBER. COD FREIGHT RETURNS WILL NOT BE ACCEPTED. FREIGHT COLLECT SHIPMENTS WILL NOT BE ACCEPTED. WARRANTY REPAIRS MUST BE ACCOMPANIED BY DATE OF PURCHASE RECEIPT AND A RETURN/REPAIR AUTHORIZATION NUMBER.

RETURN/REPAIR AUTHORIZATION NUMBER: _____

MACHINE SERIAL NUMBER: _____



9250 Xylon Avenue N • Minneapolis, MN 55445 • U.S.A.
Toll-free 800-245-0267 • Phone 763-315-5300 • Fax 800-648-7124 • Fax 763-535-8255
Web Site: www.nationalequipment.com • E-Mail: info@nationalequipment.com