

8000 PROPANE RIDE-ON SCRAPER OPERATING & SERVICE MANUAL



Read Manual Before Operating or
Servicing Machine

402233 Rev J

Table of Contents

Table of Contents	3
Features and Specifications	4
Safety	7
General Rules For Safe Operation	7
Ride-On Scraper Safety Guidelines	8
Hydraulic Safety	9
Components and Assembly	10
Transport	10
Jobsite Movement	10
Cutting Head and Blades	11
Foot Pegs	12
Storage	12
Bracket Configuration	13
Operation	14
Start-Up Procedure	14
Operating Elements	14
Shut-Down Procedure	15
Slide Plate Adjustment and Settings	15
Steep Cutting Head Angle	16
Changing Propane Tank	16
Removable Weights	17
Application Setup	18
Ditching	19
Headlight	19
Maintenance Schedule	20
Troubleshooting Guide	21
Maintenance	22
Dual Slide Plate Removal	22
Leak Maintenance	22
Hydraulics	22
Replace Pump	23
Replace Valve	23
Replace Wheel Motor	23
Replace Wheel	24
Replace Caster	24
Clean Air Cleaner Foam Element	24
Clean Air Cleaner Paper Element	24
Replace Air Cleaner	25
Check Engine Oil	25
Change Engine Oil and Filter	25
Clean and Regap Spark Plug	25
Seat Replacement	26
Remove/Replace Foot Peg	26
Telematics Option	26
Parts List and Diagrams	27
Wiring Diagrams	44
Warranty	46

Features and Specifications



FEATURES

Non-Marking Tires - Work on all types of applications and debris build up.

Seat Switch - Operator must be seated for machine to run.

Hydraulic Steering - Move forward or in reverse, turn, and brake with easy-to-move levers.

Hydraulic Slide Plate - Affords maximum versatility in blade settings.

Adjustable Foot Pegs - Provides optimal comfort and ergonomics.

Quick-Change Swivel Head - Assures continuous blade contact with the floor.

Fork Lift Cups - Easily accessible for loading and unloading.

Cylinder Adjustment - Ability to adjust the height of the slide plate and allows precise angle adjustment of the cutting head with hand controls.

Headlight - Illuminates work zone.

Features and Specifications

Product Specifications

Width	Length	Height	Weight (Machine Only)	Weight*	Speed	RPM	HP
30.0" (76 cm)	63.0" (160 cm)	65.5" (166 cm)	1,920 lbs (871 kg)	3,010 lb (1,365 kg)	Up to 200 ft/min. (61 m/min.)	2950	25 (18.6 kW)

*Weight includes removable weights, cutting head and transport wheels.

Machine Variants

Region	Serial Number	Body Panels	Slide Plate
Domestic (North America)	8000-10XXXX	Silver Vein	Dual Lift
	8000-12XXXX	Green	Dual Lift
	8000-23XXXX	Silver Vein	Dual Lift
International	8000-33XXXX	Silver Vein	Dual Lift

THIS PAGE INTENTIONALLY LEFT BLANK

GENERAL RULES FOR SAFE OPERATION

Before use, anyone operating or performing maintenance on this equipment must read and understand this manual, as well as any labels packaged with or attached to the machine and its components. Read the manual carefully to learn equipment applications and limitations, as well as potential hazards associated with this type of equipment. Keep manual near machine at all times. If your manual is lost or damaged, contact National Flooring Equipment (NFE) for a replacement.

Personal

Dress properly and use safety gear.

Do not wear loose clothing; it may be caught in moving parts. Anyone in the work area must wear safety goggles or glasses and hearing protection. Wear a dust mask for dusty operations. Hard hats, face shields, safety shoes, etc. should be worn when specified or necessary. Wear the provided Carbon Monoxide (CO) lapel monitor when operating.

Maintain control; stay alert.

Keep proper footing and balance, and maintain a firm grip. Observe surroundings at all times. Do not use when tired, distracted, or under the influence of drugs, alcohol, or any medication that may cause decreased control.

Keep hands away from all moving parts and blades.

Wear gloves when changing blades. Remove blade when machine is not in use and/or lower cutting head to the floor.

Do not force equipment.

Equipment will perform best at the rate for which it was designed. Excessive force only causes operator fatigue, increased wear, and reduced control.

Environment

Avoid use in dangerous environments.

Do not use in rain, damp or wet locations, or in the presence of explosive atmospheres (gaseous fumes, dust, or flammable materials). Remove materials or debris that may be ignited by sparks. Keep work area tidy and well-lit - a cluttered or dark work area may lead to accidents. Extreme heat or cold may affect performance.

Protect others in the work area and be aware of surroundings.

Provide barriers or shields as needed to protect others from debris and machine operation. Children and other bystanders should be kept at a safe distance from the work area to avoid distracting the operator and/or coming into contact with the machine. Operator should be aware of who is around them and their proximity. Support personnel should never stand next to, in front of, or behind the machine while the machine is running. Operator should look behind them before backing up.

Guard against electric shock.

Prevent bodily contact with grounded surfaces, e.g. pipes, radiators, ranges, and refrigerators. When scoring or making cuts, always check the work area for hidden wires or pipes.

Equipment

Use proper parts and accessories.

Only use NFE-approved or recommended parts and accessories. Using any that are not recommended may be hazardous.

Ensure accessories are properly installed and maintained.

Do not permanently remove a guard or safety device when installing accessories.

Inspect for damaged parts.

Check for misalignment, binding of moving parts, loose fasteners, improper mounting, broken parts, and any other conditions that may affect operation. If abnormal noise or vibration occurs, turn the machine off immediately. Do not use if ignition switch does not turn machine on and off. For repairs, insist on identical NFE parts.

Maintain equipment and labels.

Keep handles dry, clean, and free from oil and grease. Keep cutting edges sharp and clean. Follow instructions for lubricating and changing accessories. Motor and switches should be completely enclosed at all times with no exposed wiring. Inspect cord regularly. Labels carry important information; if unreadable or missing, contact NFE for a free replacement.

Avoid accidental starting; store idle equipment.

When not in use, ensure that the machine's propane valve is closed. Store in a dry, secured place. Remove blades when storing, and keep away from children.

Wear CO lapel monitor (NFE # 75007) when operating.

The presence of CO will change the impregnated silica color from red to burgundy, then to gray or black as the concentration levels increase. Once the detector is exposed to fresh air, it will return back to red. An unopened pack will last 2-3 years (expiration date is visible through unopened package on the back). Once opened it should be replaced approximately every 90 days.

Maintenance & Repairs

Begin maintenance work only when the machine is shut down, the propane valve is closed, and the engine has cooled.

Use proper cleaning agents.

Ensure that all cleaning rags are fiber-free; do not use any aggressive cleaning products.

Ensure machine is properly cleaned and serviced.

Remove all traces of oil, combustible fuel, or cleaning fluids from the machine and its connections and fittings. Retighten all loose fittings found during maintenance and repair work. Loose or damaged parts should be replaced immediately; use only NFE parts.

Do not weld or flame-cut on the machine during repairs without authorization from NFE.

Safety

RIDE-ON SCRAPER SAFETY GUIDELINES

Before use, anyone operating this equipment must read and understand these safety instructions.

Scraping

Do not drive machine along hills or uneven surfaces.

The weight of the machine may become distributed differently if on an uneven surface. Too much of an angle could make the machine unsafe or cause it to tip over. Always keep the front of the machine facing downward while traveling up or down ramps or inclines. Do not run the machine in unsafe environments.

Observe location of electrical supplies and extension cords.

Do not allow cutting heads to come into contact with any electrical supply or extension cord.

Operator must be seated before starting machine and should stay seated until motor has stopped running.

This machine is equipped with a safety switch under the seat, which requires the operator to be seated before the machine can be operated. Do not attempt the start-up procedure without first being seated on the machine.

Be aware of protrusions (stud anchors, re-bar, threaded rod, etc.), cracks, and expansion joints.

Battery

Remove personal metal items when working with batteries.

A battery can produce a short circuit current sufficient enough to weld metal objects, causing severe burns. Be careful to not drop metal tools on the battery, as a spark or short circuit could cause an explosion.

Never smoke or allow a spark or flame near the battery.

Do not block the machine's air flow.

Blocking ventilation slots or air flow will result in damage to the machine. Leave space for air to flow freely during operation.



WARNING: BE CAUTIOUS WHEN WORKING WITH BATTERY. IF ELECTROLYTIC ACID GETS IN THE EYES, IMMEDIATELY FLUSH OUT WITH COLD, FRESH WATER FOR AT LEAST 10 MINUTES AND GET MEDICAL HELP.

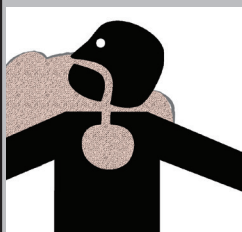

WARNING: GRINDING/CUTTING/DRILLING OF MASONRY, CONCRETE, METAL AND OTHER MATERIALS CAN GENERATE DUST, MISTS AND FUMES CONTAINING CHEMICALS KNOWN TO CAUSE SERIOUS FATAL INJURY OR ILLNESS, SUCH AS RESPIRATORY DISEASE, CANCER, BIRTH DEFECTS OR OTHER REPRODUCTIVE HARM. IF YOU ARE UNFAMILIAR WITH THE RISKS ASSOCIATED WITH THE PARTICULAR MATERIAL BEING CUT, REVIEW THE MATERIAL SAFETY DATA SHEET AND/OR CONSULT YOU EMPLOYER, THE MATERIAL MANUFACTURER/SUPPLIER, GOVERNMENTAL AGENCIES SUCH AS OSHA AND NIOSH AND OTHER AUTHORITIES ON HAZARDOUS MATERIALS. CALIFORNIA AND SOME OTHER AUTHORITIES, FOR INSTANCE, HAVE PUBLISHED LISTS OF SUBSTANCES KNOWN TO CAUSE CANCER, REPRODUCTIVE TOXICITY, OR OTHER HARMFUL EFFECTS. CONTROL DUST, MIST AND FUMES AT THE SOURCE WHERE POSSIBLE. IN THIS REGARD USE GOOD WORK PRACTICES AND FOLLOW THE RECOMMENDATIONS OF THE MANUFACTURER/SUPPLIER, OSHA/NIOSH, AND OCCUPATIONAL AND TRADE ASSOCIATIONS. WHEN THE HAZARDS FROM INHALATION OF DUST, MISTS AND FUMES CANNOT BE ELIMINATED, THE OPERATOR AND ANY BYSTANDERS SHOULD ALWAYS WEAR A RESPIRATOR APPROVED BY OSHA/MSHA FOR THE MATERIAL BEING CUT.

HYDRAULIC SAFETY

Maintaining a Safe Work Environment

Establishing a safe work environment in and around your hydraulic equipment is extremely important. The easiest and most effective way to avoid problems is to make sure associates understand their equipment, know how to operate the machines safely, and recognize the dangers if handled carelessly. A few things to be aware of are:

- **Pressure:** Hydraulic fluid under pressure is dangerous and can cause serious injury. Never look for a leak when unit is under pressure. Using your hand could cause serious injury. A few common ways to encounter hydraulic fluid under pressure include:
 - Pinhole: Fluid under pressure can cause serious injury. It can be almost invisible escaping from a pinhole, and it can pierce the skin into the body.



DANGER: DO NOT TOUCH A PRESSURIZED HYDRAULIC HOSE ASSEMBLY WITH ANY PART OF THE BODY. IF FLUID PUNCTURES THE SKIN, EVEN IF NO PAIN IS FELT, A SERIOUS EMERGENCY EXISTS. OBTAIN MEDICAL ASSISTANCE IMMEDIATELY. FAILURE TO DO SO COULD RESULT IN LOSS OF THE INJURED BODY PART OR DEATH.

- Leak: Keep fittings and hoses tight. Only check and service when not under pressure. Leaking hydraulic fluid is hazardous; in addition to making workplace floors slippery and dangerous, it also contaminates the environment. Before cleaning an oil spill, always check EPA, state, and local regulations.
 - Burst: Whether due to improper selection or damage, a ruptured hose can cause injury. If it bursts, a worker can be burned, cut, injected, or may slip and fall.
 - Coupling Blow-Off: If the assembly is not properly made or installed, the coupling could come off and hit or spray a worker, possibly resulting in serious injury. Never operate machine without guards.
- **Flammability:** When ignited, some hydraulic fluids can cause fires and/or explode. With the exception of those comprised primarily of water, all hydraulic fluid is flammable (including many “fire-resistant” hydraulic fluids) when exposed to the proper conditions. Leaking pressurized hydraulic fluids may develop a mist or fine spray that can flash or explode upon contact with a source of ignition. These explosions can be very severe and could result in serious injury or death. Precautions should be taken to eliminate all ignition sources from contact with escaping fluids, sprays or mists resulting from hydraulic failures. Sources of ignition could be electrical discharges (sparks), open flames, extremely high temperatures, sparks caused by metal-to-metal contact, etc.



CAUTION: NEVER USE YOUR HANDS TO CHECK FOR LEAKS OVER HOSE OR HYDRAULIC CONNECTIONS. USE A PIECE OF CARDBOARD TO LOCATE A PRESSURIZED LEAK. FOR LOW PRESSURE LEAKS (DRIPS), USE A RAG TO CLEAN THE AREA AND DETERMINE WHERE THE LEAK ORIGINATES.

- **Mechanical:** Hydraulic fluid creates movement, which means some equipment may move. Observe surroundings and equipment at all times.
- **Moisture:** Do not use in wet or high moisture conditions.
- **Electrical:** Faulty wiring can be an electrical hazard. A regular preventive maintenance program should always include a wiring check. If applicable, disconnect battery before servicing.
- **Temperature:** Because this machine operates at a relatively low pressure, overheating is not common. If surface of tank becomes too hot to touch by hand (above 130°F or 55°C), shut off machine and allow it to cool.

Hydraulic Fluid

Only use Texaco Rando 46 Hydraulic Oil or compatible fluid like ISO or AW #46 from a brand name manufacturer. Non-compatible fluids could cause damage to unit or serious injury.

Components and Assembly

TRANSPORT

- Secure machine with ratchet straps during transport. Proper securing straps need to be rated at least twice the weight of the machine.
- Chock wheels to keep machine from rolling, but do not use them on their own.
- Hydraulic levers should be straight up in the neutral position, not locked in the forward or backward positions.
- Lift machine off swivel caster by lowering cutting head for better stabilization. Use transport wheels when doing this.
- Remove blade, cutting head, and added weights during transport.
- Cutting head and slide plate can be removed to make machine more compact.
- Never leave machine unattended on an incline.



CAUTION: MACHINE IS BACK HEAVY. DO NOT RUN ON STEEP INCLINE THIS COULD CAUSE MACHINE TO TIP OVER! (FIGURE 1). DO NOT USE A RAMP TO MOVE MACHINE.



WARNING: MACHINE HAS A SWIVEL FRONT CASTER. NEVER SIDE HILL (FIGURE 2) THE MACHINE ON A INCLINE WITHOUT POWER, THE FRONT CASTER WILL CAUSE MACHINE TO SWING TO THE LOWEST POINT. IF IT IS NECESSARY TO RUN MACHINE ON AN INCLINE, RUN MACHINE ON CUTTING HEAD. PLACE AT LEAST AN 8" CUTTING HEAD IN MACHINE. TO KEEP FROM DAMAGING FLOOR, CLAMP A PIECE OF CARPET INTO CUTTING HEAD. THIS WILL GIVE POSITIVE CONTACT WITH THE FLOOR WHEN POWER IS DISENGAGED FROM THE WHEELS.

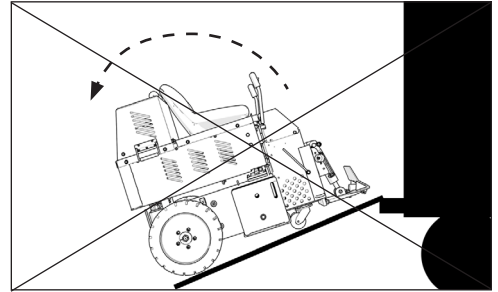

FIG. 1

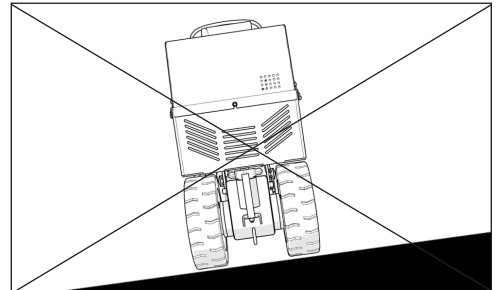

FIG. 2

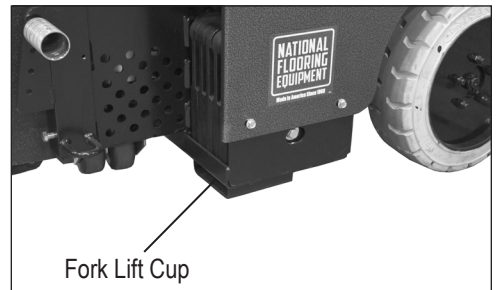

FIG. 3



FIG. 3.1

Dock Heights

It is best to load or unload the machine from a level dock height.

Power Gate

A power gate can be used when the dock height is not available. Ensure gate is properly rated for 3,000 lbs (1,361 kg). To better secure machine, place onto the lowered cutting head; raise machine off the caster. Tie machine down and chock wheels.

Forklift Cups

There are two forklift cups mounted under the front of the machine (Figure 3). Slide forklift forks through the cups, then slide as far back as possible (Figure 3.1). Before lifting machine, secure it to the forklift with 3,000 lbs (1,361 kg) or heavier straps or a chain. Tilt forks back to lift machine.

Palletizing

Only use a solid platform pallet. If a solid platform pallet is not available, place a piece of ¾" plywood on top of a pallet. Using a forklift, with the forks inserted in the forklift cups, place machine on pallet. Use properly rated ratchet straps to secure machine to pallet.

JOB SITE MOVEMENT

Taping Wheels

Taping the wheels with a wide masking tape helps prevent dirtying and damaging the floors during move-in and move-out.

Components and Assembly



FIG. 4

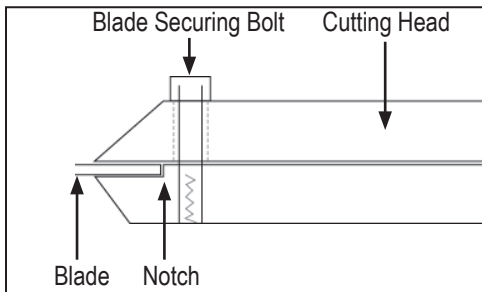

FIG. 5

Transport Wheels

The front wheel assembly (Figure 4) is included and very helpful when moving a machine around on a jobsite or loading a machine that is not on a pallet. It allows machine stability and safe transportation over most surfaces. It is quick and easy to attach or detach.

1. Raise slide plate so the bottom of the slide plate is higher or even with the bottom of the guide channels, 6"-8" (15.25-20.3 cm) is ideal.
2. Raise cylinder; insert front wheel assembly into cutting head.
3. Secure with pin.

When finished, the caster wheels should swivel freely and the front wheel plate should be parallel with the floor.

CUTTING HEAD AND BLADES



WARNING: BLADES ARE SHARP, USE EXTREME CAUTION. ALWAYS WEAR GLOVES AND SAFETY GLASSES WHEN HANDLING BLADES. NEVER CHANGE CUTTING HEAD OR SERVICE BLADES WHILE MACHINE IS RUNNING.

Matching the correct cutting head, blade size, blade angle, and added weight to the machine is important. For every material being removed, there is an optimum blade width, thickness, sharpness, angle, and bevel (up or down).

The machine is supplied with a 6" and 12" cutting head. Having additional cutting heads will save time on the job. Insert blades into the extra cutting heads before starting a job. When the blade is dull, take out the cutting head and replace it with another.

Shear Point

The shear point is the point where material to be removed will cut cleanly from the floor. If the blade is too wide, too dull, or too steep the shear point is lost.

Inserting the Cutting Head

1. With machine off, insert desired cutting head into cutting head holder.
2. Secure with cutting head clip.

Swivel Head

The swivel head keeps the blade in contact with the floor even when the floor is uneven. When using a flat blade, turning the head over 180° provides another sharp edge on the blade without having to replace the blade.

Inserting or Changing Blades

Sharp blades are imperative for good performance.

1. Using a 3/4" socket wrench, loosen bolts on cutting head. Quantity of bolts will vary depending upon cutting head size.
2. Insert blade into the cutting head to back of notch (Figure 5); tighten firmly.

Note: A cordless 3/8" drive impact wrench will speed up this process.

Inserting a Shank Blade

Shank blades do not require a cutting head.

1. Insert desired shank blade into cutting head holder.
2. Secure with cutting head clip.

Components and Assembly

Self-Scoring Blades

Instead of pre-scoring a job for soft goods (e.g. carpet, vinyl, linoleum, membrane), the self-scoring blades automatically do the scoring.

Sharpening Blades

Dull blades greatly reduce cutting ability. Sharpen or replace as needed. In use, blades develop a back-bevel. When sharpening, blade will not be completely sharp until all back-bevel is gone (Figure 6).

Note: *Thinner blades are easier to sharpen, but they also break easier.*

- Grind blade using a 4" diameter disk with 120 or finer grit. Be careful not to catch disk on edge or corner of blade.
- Pass grinder along blade edge starting on one end and continuing in one direction, being careful to hold grinder at proper angle of blade. Grind until sharp.
- When using a high quality fine tooth hand file, follow the same procedure as above.
- Have plenty of sharp blades on each job so on-the-job sharpening is eliminated.
- It is best to sharpen dull blades on proper bench or belt grinder in the shop, so the blades are ready for the next job.

Self-Scoring Blade Sharpening: It is important to keep the "wings" on a self-scoring blade sharp. Use a file on the wing edge (Figure 6). Sharpen the flat part of the blade, the same way as described above.

Carbide-Tipped Blade Sharpening: To sharpen carbide tipped blades, a carbide grinding wheel is necessary, e.g. silicon carbide or green wheel.

Blade Selection

- Proper blade size and placement, depending on material and sub-floor type, affects performance.
- For better results during difficult removal applications use a smaller blade.
- Start with a narrow blade, then increase blade size to optimize cutting pass.
- Narrower blades work easier than wider blades and usually clean the floor better. Wider is not always better or faster.
- Normally, bevel on blade is up for concrete (Figure 7); bevel down for wood (Figure 7.1)
- Dull blades greatly affect the performance of the machine and reduce cutting ability, sharpen or replace as needed.
- After removing a portion of material, clear the work area of debris. This will give the machine maximum performance and help to keep the work area safe.

FOOT PEGS

Rest feet on foot pegs while operating machine. Foot pegs are adjustable. Ensure securing knob is tightened.

STORAGE

Follow the shut-down procedure. After engine has completely cooled down, disconnect propane line and remove negative terminal on battery.

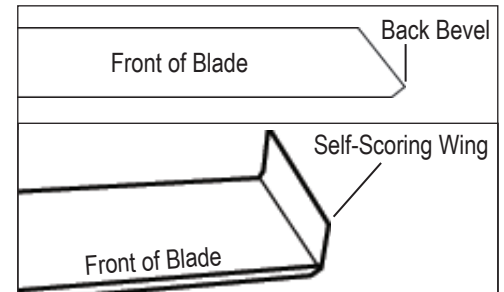

FIG. 6

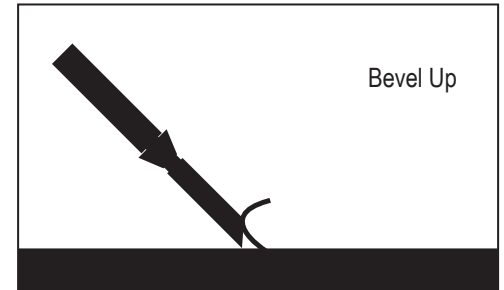

FIG. 7

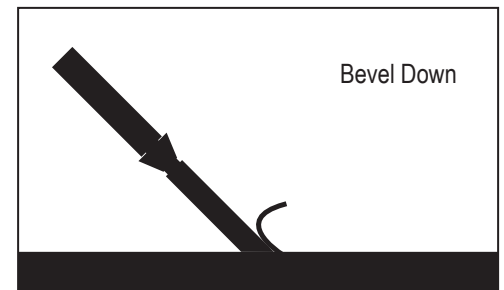

FIG. 7.1

Components and Assembly

BRACKET CONFIGURATION

Your machine will arrive from National Flooring Equipment (NFE) with the bracket bolted to the floor of the crate; it will require configuration on the machine prior to use.

If your propane tank has a length of approximately 21 inches (NFE tank size)...

Unbolt the bracket from the crate; use the bolts already connected to the hood to configure the bracket on the machine as follows (Figure 8):

1. L shapes on the bracket should be facing outward (Figure 8A).
2. Right side of the bracket should be bolted to the outermost set of holes on the right.
3. Left side of bracket should be bolted to the holes second-furthest from the left.

If your propane tank has a length of approximately 28 inches (fork lift tank size)...

Unbolt the bracket from the crate; use the bolts already connected to the hood to configure the bracket on the machine as follows (Figure 9):

1. L shapes on the bracket should be facing inward (Figure 9A).
2. Right side of the bracket should be bolted to the outermost set of holes on the right.
3. Left side of bracket should be bolted to the outermost set of holes on the left.

Note: Holes may be hidden by label. Find the holes by running your hand over the label; cut the label so that they are usable.

For assistance, contact NFE Customer Service.

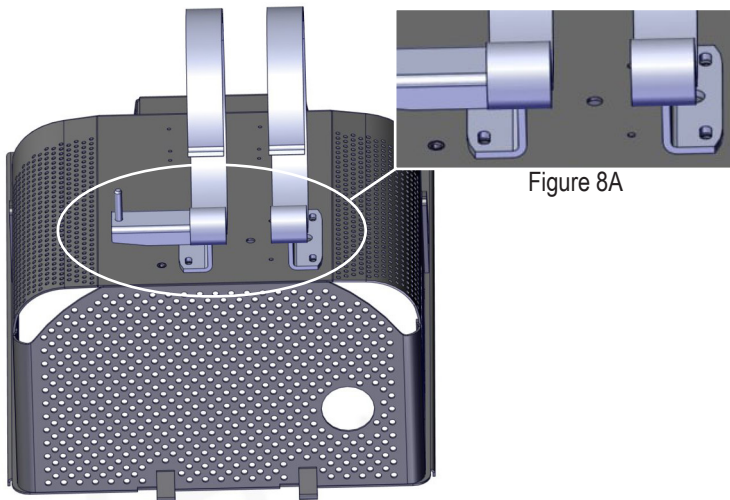

Figure 8

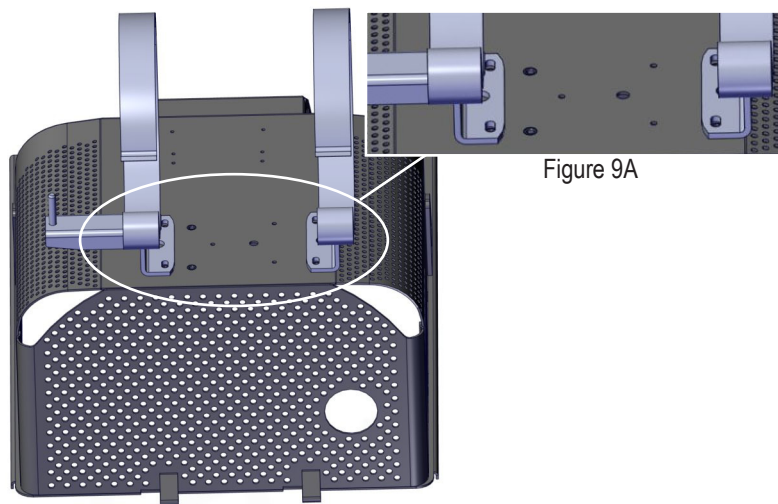

Figure 9

Operation

START-UP PROCEDURE

1. Open propane tank valve by turning knob counterclockwise until fully open.
2. Operator must be seated for the machine to run.
3. Ensure hydraulic levers are centered/neutral.
4. Set throttle at a quarter open.
5. Start with ignition key switch. Both a red & green light will illuminate (Figure 10). As soon as engine starts, the red light will shut off. **Note:** If the red light does not shut off, turn machine off.
6. Machine should be at full throttle while in use.

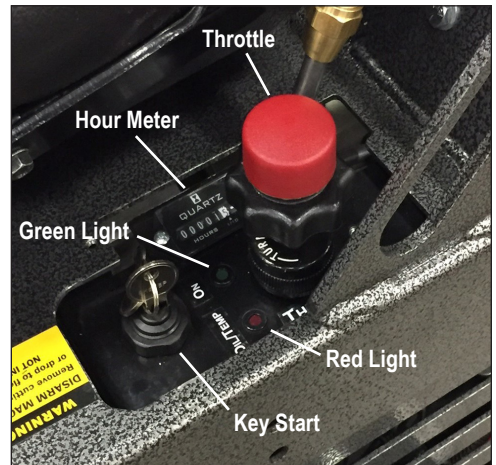

FIG. 10



WARNING: VENTILATION IS REQUIRED IN CONFINED WORK ENVIRONMENTS. CARBON MONOXIDE IS A VERY TOXIC, COLORLESS AND ODORLESS GAS. WHEN ENGINES OPERATE IN ENCLOSED SPACES, SUCH AS WAREHOUSES, BUILDINGS UNDER CONSTRUCTION, OR TUNNELS, CARBON MONOXIDE CAN ACCUMULATE QUICKLY AND REACH CONCENTRATIONS THAT ARE DANGEROUS FOR HUMANS. IT CAUSES HEADACHES, DIZZINESS, LETHARGY AND DEATH. CO IS USUALLY THE MAJOR CONCERN WHENEVER LPG ENGINES ARE USED INDOORS

OPERATING ELEMENTS

Throttle Control (Figure 11)

1. Ensure throttle is pushed down (quarter open) prior to starting machine.
2. Start machine.
3. Adjust throttle to desired RPM by pulling up on the throttle control.
4. When at desired RPM, turn throttle friction knob counterclockwise to hold in position.

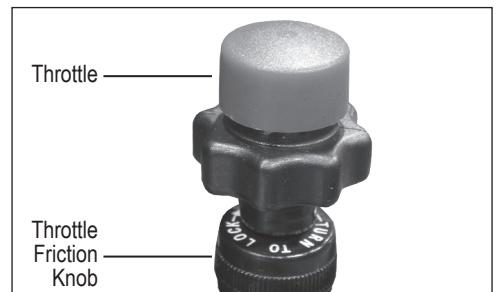

FIG. 11

Hydraulic Levers (Figure 12)

The hydraulic levers are metered spool valves that steer the machine. For smooth, even movement, always move levers slowly. Fast movement will result in jerky, uneven operation.

- To move the machine forward, push both levers forward $\blacktriangle\blacktriangle$.
- To move the machine in reverse, pull both levers backward $\blacktriangledown\blacktriangledown$.
- To turn the machine quickly to the right, move the left lever forward and the right lever backward $\blacktriangle\blacktriangledown$.
- To turn the machine quickly to the left, move the left lever backward and the right lever forward $\blacktriangledown\blacktriangle$.
- To turn the machine slowly to the right or left, push or pull only the right or left lever forward \blacktriangle or \blacktriangledown .
- Putting the levers in the center/neutral position causes the wheels to lock-up.



FIG. 12

To correct direction while moving forward, slightly reduce pressure on one lever or the other.

Safety Switch

The seat has a safety switch. Operator must be properly positioned for machine to run.

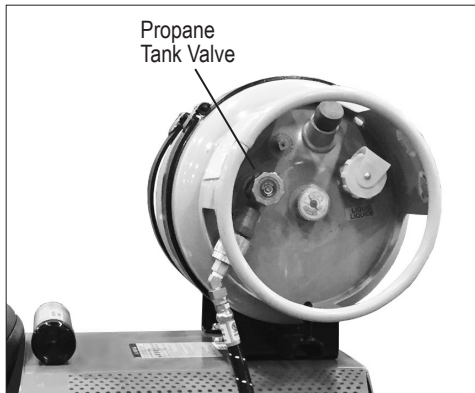

FIG. 13



FIG. 14

Cylinder Lift

The cylinder lift lever raises and lowers the cylinder and cutting head. After setting the slide plate to proper height, use the cylinder lift lever to set blade to proper cutting angle.

- To raise the cutting head, pull back ▼ on the cylinder lift lever.
- To lower the cutting head, push the cylinder lift lever forward ▲.
- Continuing to push the cylinder lift lever forward will adjust the angle of the cutting head. This will also jack up the front of the machine for maintenance purposes.

SHUT-DOWN PROCEDURE

1. Move machine to level ground; turn off the ignition switch and remove the key. The machine will also stop when the operator is no longer seated.
2. Once the ignition switch is off and pressure is relieved, the hydraulic brakes will engage.
3. Wait until motor has stopped completely. **Note:** Machine must be lifted to move while not running.
4. Close propane tank valve (Figure 13).
5. Let the engine, exhaust system, and hydraulic components cool down before performing maintenance on the machine.
6. Remove blade or drop cutting head to the floor when machine is not in use.

SLIDE PLATE ADJUSTMENT AND SETTINGS

Dual Lift (Figure 14)

- Prior to adjusting the dual lift hydraulic slide plate, ensure the channel guide is free of any debris and the machine is safely positioned on a flat surface.
- To set the height of the hydraulic slide plate start, adjust the angle of the cutting head holder with the cylinder lift lever. Pull back on the cutting head lever and raise the cutting head holder to an angle higher than the bottom of the slide plate.
- The lever adjacent to the right hand control lever raises and lowers the hydraulic slide plate. To lower the slide plate, push forward on this lever. To raise the slide plate, pull back on the lever.

Settings

While the hydraulic slide plate can be adjusted to multiple positions there are two basic slide plate settings.

- **Low Setting:** The hydraulic slide plate is positioned 1" (2.5 cm) off the floor. This setting is most commonly used during initial scraping or removal applications; such as carpet, VCT, ceramic tile and wood flooring. (Note: The "low" setting on older model hydraulic slide plates may stop the plate within one to two inches of the floors surface.)
- **High Setting:** The hydraulic slide plate is positioned 6" (15 cm) off the floor or in most cases flush with the bottom of the slide plate channel guide. This setting is most often used for re-scraping glues, mastics, thin sets and soft coating.

Operation

STEEP CUTTING HEAD ANGLE

A steep angle is only used for re-scraping. The slide plate has to be raised so the bottom of the plate is higher or even with the bottom of the guide channels (Figure 15). Raising the slide plate to an angle too steep when operating will cause the machine to jump and buck. It does not give the operator a clear vision of the cutting head and it raises the machine to operate at a unsafe height (Figure 15.1).

CHANGING PROPANE TANK



CAUTION: BE SURE TO USE A VAPOR DRAW PROPANE TANK. USING THE WRONG TANK COULD CAUSE THE REGULATOR TO FREEZE UP AND ENGINE TO OVERHEAT.

1. Follow shut-down procedure to turn off machine.
2. Release tank bracket so that it swings back. It does not need to be removed completely (Figures 16 and 16.1).
3. Disconnect propane hose (Figures 16 and 16.1).
4. Remove tank.
5. Reverse steps for replacement. When replacing, make sure the bracket locating pin engages with the hole on the tank.

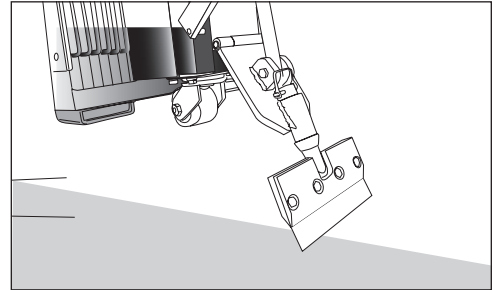

FIG. 15

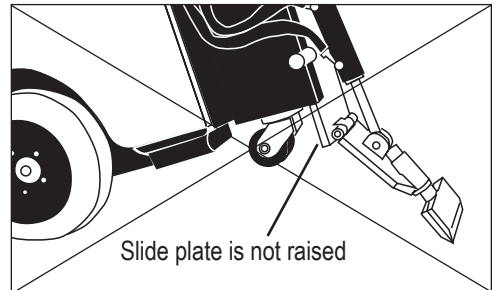

FIG. 15.1

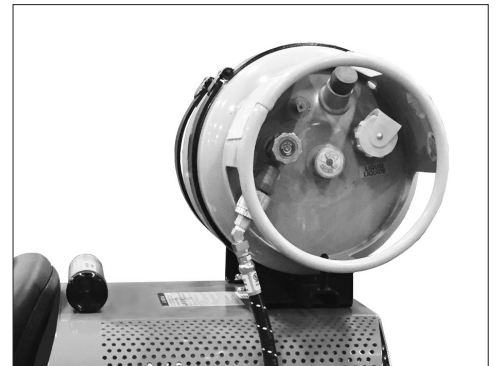

FIG. 16

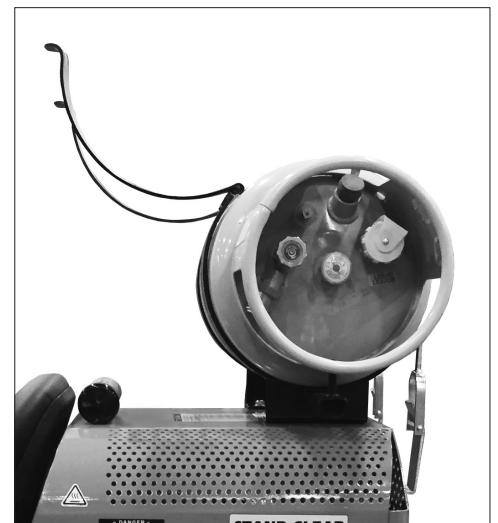

FIG. 16.1

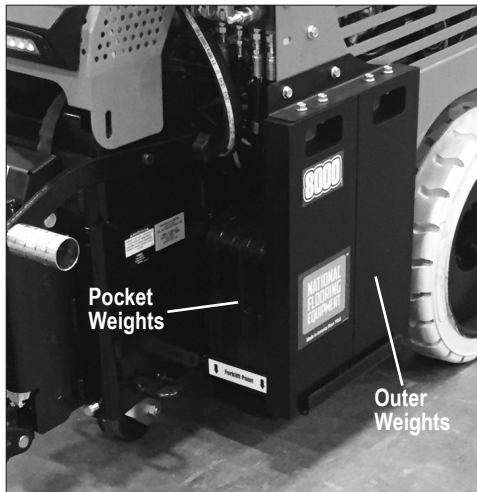

FIG. 17

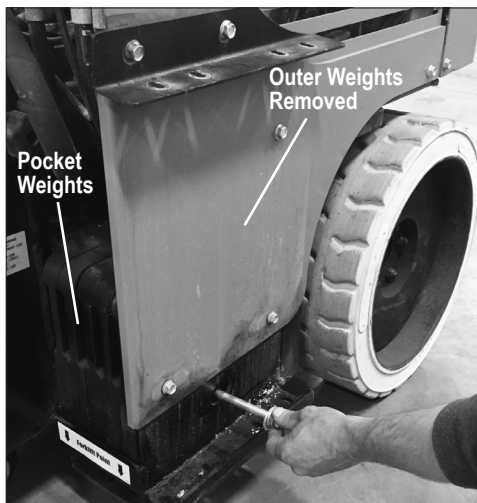

FIG. 18

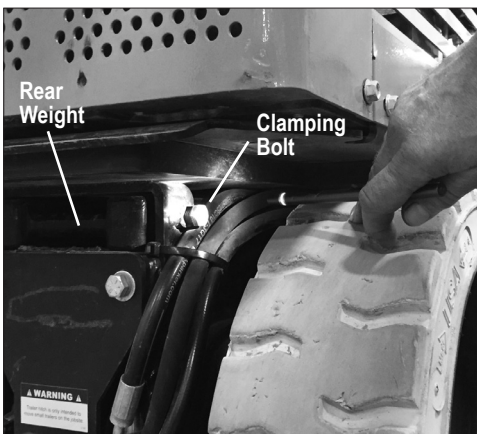

FIG. 19

REMOVABLE WEIGHTS

The machine has removable weights which may be off-loaded to lessen the weight of the machine depending on the application. See service manual for the parts diagrams of the removable weights.



WARNING: WEIGHTS ARE HEAVY—USE CAUTION WHEN HANDLING AND AVOID PINCH POINTS AS BODILY INJURY COULD RESULT.

Outer Weights (Figure 17)

4 used (2 per side), 85 lbs each

1. Remove bottom mounting bolts.
2. Loosen upper bracket bolts.
3. Remove top mounting bolts.
4. Remove outer weights.

Pocket Weights (Figure 18)

10 used (5 per side), 38 lbs each

Note: The outer weights must be removed first in order to gain access to the mounting bolt for the pocket weights.

1. Remove mounting bolt.
2. Remove pocket weights.

Rear Weight (Figure 19)

1 used, 75 lbs

1. Loosen clamping bolt.
2. Remove rear weight.

Front Weights (Figure 20 and 21)

Large Front Weights: 2 used, 56 lbs each

Small Front Weights: 9 used, 27 lbs each

1. Lift hood to gain access to front weights.
2. Loosen the two clamping bolts (Figure 21) to remove compression on the weights.
3. Remove large front weights.
4. Remove small front weights, starting with the middle weights first. Move hydraulic hoses to the side for easier removal of the weights.

Operation

APPLICATION SETUP

Ceramic (Figure 22)

The slide plate should be adjusted to a low setting 1" (2.5 cm) off the floor. Use a shank blade or a shank blade with a carbide tip.

Wood

The slide plate should be adjusted to a low setting 1" (2.5 cm) off the floor. Use shank blades, shank blades with carbide tips, or a 6" or 8" (15-20 cm) cutting head with heavy duty blades.

Note: Run machine 45° to the grain of the wood.

Secondary Backing Carpet

The slide plate should be adjusted to a low setting 1" (2.5 cm) off the floor. Use a cutting head from 10"-27" (25-68 cm) with heavy duty blades or a cutting head from 10"-14" (25-35 cm) with a self-scoring blade.

Foam Back Carpet

The slide plate should be adjusted to a low setting 1" (2.5 cm) off the floor. Use cutting heads from 10"-14" (25-35 cm) with self-scoring blades. If it is not stuck tight, use a cutting head from 14"-27" (35-68 cm) with a standard blade.

Double Stick Carpet

The slide plate should be adjusted to a low setting 1" (2.5 cm) off the floor. It is best to test to see which is the easiest way to remove double stick. Start with a cutting head from 10"-14" (25-35 cm) with self-scoring blades. Use self-scoring blades with 4" wings, 6" or 12" wide for best results. In some cases, carpet might pull off the pad and then scrape up the pad separately. Usually leaving carpet connected to the pad works the best. Sharp blades are necessary for proper operation.

Note: When removing carpet from over VCT tile and the tile needs to be saved, run the machine at a 45° angle over the tile. This should help to save the tile.

Vct Tile

The slide plate should be adjusted to a low setting 1" (2.5 cm) off the floor. If goods come up easily, change to a larger cutting head. If goods come up harder, use a cutting head from 6"-8" (15-20 cm) with a premium high-tempered blade (.062) to match cutting head size. Sometimes a .094 blade may work better. If goods remove easily, a tile box (#7074) can be used. A tile box also works for wind rowing, and assists for a fast clean-up and collection of tile debris for quick removal.

Rubber Tile

The slide plate should be adjusted to a low setting 1" (2.5 cm) off the floor. Use a cutting head from 6"-14" (15-35 cm) with self-scoring blades or use ditching method with a flat blade.

Re-Scraping

Slide plate should be set high, 6"-8" (15-20 cm) off the floor. Use a razor blade cutting head from 8"-27" (20-68 cm) with scraper blades to match cutting head size. A 15" (38 cm) scraper blade would use a 14" (34 cm) cutting head. Flip head regularly.

Thin Coating and Glues

Slide plate could be set high, 6"-8" (15-20 cm) or low 1" (2.5 cm) off the floor. Test to see which works best. Use a razor blade cutting head, available from 8" (20 cm) and up, with razor blades to match cutting head size.

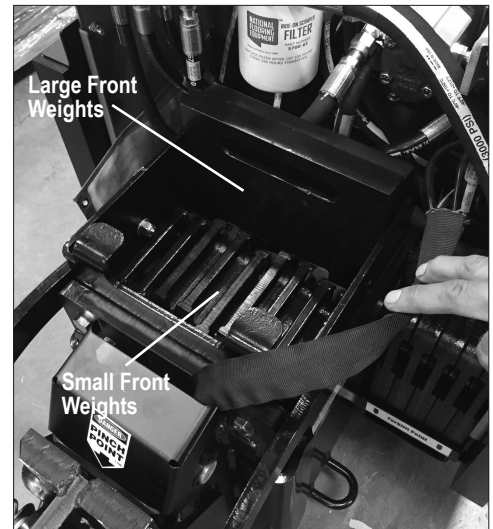
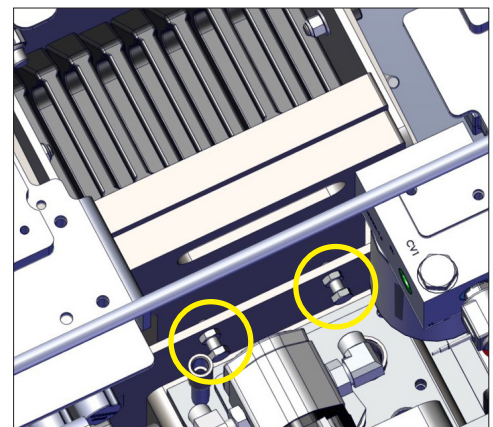

FIG. 20



Note: Some parts removed for clarity.

FIG. 21

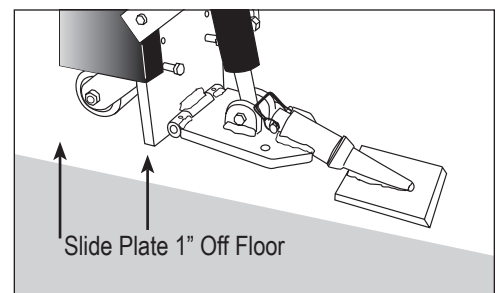
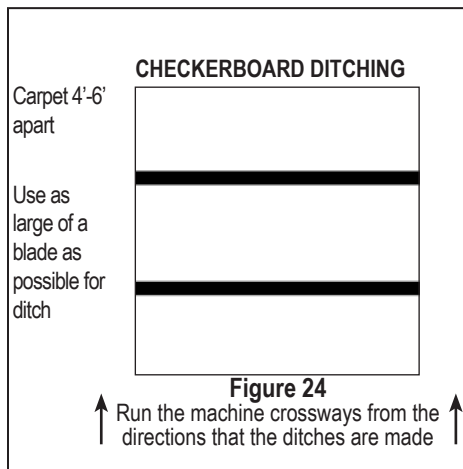
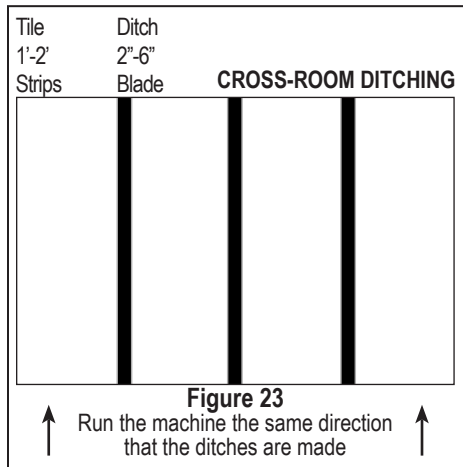

FIG. 22



Concrete

Blade should be bevel up when working over concrete. Pretty much anything over concrete works. Try different setups to see which works best. If goods come up difficult, the slide plate should be at a low setting, 1" (2.5 cm) off the floor. Use a smaller size blade. If goods come up easily, a wider blade can be used.

Wood Sub-Floor

A heavy machine cannot be used on wood subfloors or raised panel computer floors. Keep machine light; remove all weights. A weighted machine could break through the floor. The slide plate should be adjusted to a low setting, 1" (2.5 cm) off the floor. Blades should be as flat of an angle as possible. Use a heavy duty blade (these blades have a bend to them) or a regular blade bevel down. When using a regular blade, bending up the corners of the blade will help from the blade digging into the floor. Sometimes a shank blade or a shank blade with a carbide tip will work. Allow blade to shear material from the floor. The trick on wood floors is to run the blade flat. Approach should be at a 45° angle to the board. This keeps from digging into the board and hanging up at the seams.

Soft Sub-Floor

The slide plate should be adjusted to a low setting 1" (2.5 cm) off the floor. Blades should be as flat of an angle as possible. Use a heavy duty blade (these blades have a bend to them) or a regular blade bevel down. When using a regular blade, bending up the corners of the blade will help from the blade digging into the floor. Sometimes a shank blade or a shank blade with a carbide tip will work.

DITCHING

Cross Room Ditching (Figure 23)

When removing hard to remove ceramic, VCT, or VAT, cross-room ditching will help to make the removal easier. Using a blade 2"-6" (5-15 cm) in width, make ditches 1'-2' (30-60 cm) apart in the same direction the machine will be removing the goods. This relieves the pressure holding the tiles together. If ditching helps and the goods are coming up easy, try using a wider blade to ditch with.

Checkerboard Ditching (Figure 24)

To make carpet removal and debris clean-up easier, checkerboard ditching is very helpful. Using as wide of a self-scoring blade as possible, make ditches 4'-6' (1.25-1.75 m) crossways from the way the machine will be removing the goods. Running the machine crossways from the ditches will make smaller pieces of debris to be hauled away. Instead of large gummy rolls of carpet, there are small squares that can be rolled, palletized, put on a dolly, or folded with the sticky side in. This makes removing the debris easier and reduces the amount of debris.

HEADLIGHT

The headlight illuminates the work zone.

- Use the toggle switch to turn the headlight ON and OFF. *NOTE: The headlight only operates when the key is in the ON position.*
- The light is fixed-mounted with fixed brightness--it is not adjustable.

Maintenance Schedule

Maintenance to be performed	Interval									
	Daily	First 8 hrs	50 hrs	100 hrs	200 hrs	300 hrs	400 hrs	1000 hrs	After initial 100 hrs	After initial 500 hrs
Check all machine components for build up; clean if necessary	•									
Inspect all safety devices (backup beeper, seat switch)	•									
Inspects for leaks (hoses and fittings)	•									
Grease front caster wheel								•		
Check hydraulic oil level					•				•	
Replace the spin-on hydraulic oil filter					•				•	
Change hydraulic fluid								•		•
Check engine oil level	•									
Change engine oil		•	•							
Clean air cleaner foam/paper elements		•	•							
Replace air cleaner paper element						•				
Inspect radiator and fan belt condition/tension					•					
Change coolant							•			
Clean and regap spark plug				•						

It is recommended to perform initial maintenance during the break-in period when first operating the machine. After the first 100 operating hours the hydraulic oil level should be checked and the spin-on hydraulic oil filter should be replaced, then every 200 hours thereafter. At the 500 operating hour mark the hydraulic fluid should be changed. Regular maintenance should be performed according to the schedule.

Troubleshooting Guide

Problem	Cause	Solution
The scraper does not work when the pump is generating pressure.	Severe blockage in wheel drive motor hoses.	Check for blockage and replace hose(s) if necessary.
	Wheel drive motors are defective.	Call NFE customer service for assistance.
The hoses are worn.	Hoses are rubbing on the components.	Replace and protect the hose.
	Hose has been exposed to poor environmental conditions.	Replace hose and protect equipment from poor conditions.
The machine makes an unusually loud hissing or whistling noise.	Fluid is passing over relief valves.	If noise is continuous, call NFE customer service for assistance.
	There is air in the hydraulic circuit.	Check all suction lines; tighten all hose connections and fittings.
Oil deposits are evident on the inner sides of the wheels.	Seal is worn.	Have shaft seals replaced by a specialist.
	Hose fitting is loose or worn.	Tighten hose fitting; replace hose or fitting if necessary
The machine has no power with the engine running at 2,950 RPM.	Valve adjustment or hoses might have leaks.	Contact NFE customer service immediately. Do not operate in this condition.
The scraper does not react when the motion control joystick is actuated.		
The hydraulic oil is very cloudy.	Water has entered hydraulic tank.	Drain and clean tank thoroughly, change oil, and repair tank if necessary.
	Oil is contaminated with dirt.	Drain and clean tank thoroughly, and change oil.
	Air has entered the circuit. Stop machine and repair immediately!	Check all suction lines; tighten all hose connections and fittings.
There is an excessive amount of oil on chassis.	Outside oil spilled on chassis.	Clean machine thoroughly and see if the problem persists.
	Loose hose connections.	Tighten loose hoses.
	Loose tank fittings.	Tighten loose fittings.
Hydraulic oil and/or oil foam leaking from oil tank.	Oil level is too high.	Drain tank to correct level.
	Oil level is too low.	Fill tank to correct level.
	Vent in return filter is blocked.	Check for blockage.
	Air has entered the circuit. Stop machine and repair immediately!	Check all suction lines; tighten all hose connections and fittings
Engine dies or cuts out.	Fuel tank is empty.	Change or fill fuel tank.
	Oil is low.	Fill oil to proper level.
	Operator is not seated properly.	Ensure operator is seated correctly.
Red ignition light stays on.	Oil is Low.	Fill oil to proper level.
	Machine is overheating.	Let engine cool; add coolant to proper level.
Machine doesn't start.	Machine needs to be primed.	Press primer button once, then restart machine.

Maintenance

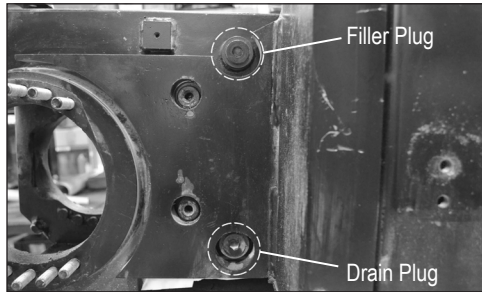

FIG. 1



WARNING: ALWAYS LET ENGINE COOL AND DISCONNECT BATTERY BEFORE PERFORMING ANY MAINTENANCE. FAILURE TO DO SO COULD CAUSE SERIOUS BODILY INJURY.

DUAL SLIDE PLATE REMOVAL



WARNING: ASSEMBLY IS VERY HEAVY. USE TEAM LIFT OR FORKLIFT TO LIFT. KEEP HANDS AND FEET OUT FROM UNDER THE ASSEMBLY. FAILURE TO DO SO COULD CAUSE SEVERE INJURY.

1. Lower the slide plate to the floor and place a wood block under the assembly.
2. Remove the front cylinder by taking the 1/2" bolt out of the bottom and removing the hitch clips and pin from the top of the cylinder.
3. Remove the E-clips from the pin at the bottom of the internal cylinder, then remove the pin.
4. Remove the pin from the top of the internal cylinder and then remove the cylinder from the machine.
5. Loosen the pinch bolt from the lower right side of the assembly.
6. Remove the lock nut from securing bolts at the top of the slide plate.
7. Remove the socket head screws at the top of the dual slide from both sides of the assembly.
8. Install 3/8-16x5" bolts into the holes the socket head screws were removed from. Once installed the bolts should be used as lifting handles.
9. Lift the assembly out of the machine.

LEAK MAINTENANCE

Most fittings on this machine are O-ring style.

1. Disconnect machine from power.
2. If a leak is detected, tighten fitting with the proper wrench size. Do not over-tighten.
Note: Most fittings on this machine are O-ring style. Over-tightening could damage to O-rings.

HYDRAULICS

Check Fluid Level

1. Remove filler plug (Figure 1).
2. Oil should be visible 1" below hole.
3. Reinsert plug.

Change Fluid

1. Let hydraulic fluid cool before maintenance. Disconnect machine from battery.
2. Drain fluid by removing the drain plug from side of tank (Figure 1). This unit contains 6 gallons (22.7 liters) of fluid. Ensure the container size is adequate to catch fluid.
3. Replace drain plug.

4. Remove filler plug (Figure 1).
5. Add oil into filler plug hole. Total tank capacity is 6 gallons (22.7 liters). Due to a certain amount of retained oil, the oil change refill amount is 5.5 gallons (20.8 liters). *NOTE: Adding more than this amount could cause the oil to overflow from the vent tube.*

Replace Cylinder

1. Follow shut-down procedure.
2. Disconnect cylinder lines. Have a container ready to catch oil from lines.
3. Remove cylinder securing hexhead bolt from lower cutting head support.
4. Remove clips and pin from cylinder and slide plate.
5. Remove cylinder upper pin.
6. Remove cylinder.

Remove or Replace Hose

1. Follow shut-down procedure.
2. Remove hood.
3. Using proper wrench size, turn the swivel nut while using a second wrench to keep the hose from turning.
4. When replacing, make sure O-ring is properly seated on hose fitting.

REPLACE PUMP

1. Open hood to expose pump.
2. Disconnect hydraulic lines.
3. Remove two 5/16" pump securing bolts.
4. Remove pump by pulling pump straight out from pump motor.

REPLACE VALVE

1. Disconnect machine from power (charger or battery).
2. Lift hood all the way back, resting on the hood bumpers.
3. Remove hoses from valve body. Mark which hoses go where, so that they can be placed back in the same order. Damage can occur if hoses are mixed up. Have a container ready to catch leakage from lines.
4. Take notice of angle of valve fittings.
5. Remove two 5/16-18" bolts securing valve body.

REPLACE WHEEL MOTOR

1. Disconnect machine from power.
2. Block up machine to remove wheel.
3. Remove wheel.
4. Remove oil lines from wheel motor. A small amount of oil will run out of the lines. Drain into a container. Wipe up spills immediately.
5. Remove ten 1/2" wheel motor securing nuts.
6. Pull out on wheel motor to remove.

Maintenance

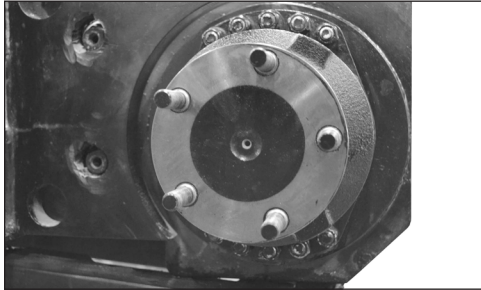

FIG. 2

REPLACE WHEEL



WARNING: WHEELS ARE EXTREMELY HEAVY. ENSURE PROPER TEAM LIFTING TECHNIQUES OR USE PROPER MACHINERY TO LIFT.

1. Jack machine up by pushing cylinder lift forward to lower and adjust the angle of the cutting head to raise machine.
2. Place blocks under Forklift Cups on the side of the machine that wheel is being changed. Make sure machine is supported properly.
4. Let cylinder down resting machine on blocks allowing rear wheel to be lifted off the floor.
5. Remove five 1/2" lug nuts with an extended arm wrench, remove wheel.
6. Replace wheel (Figure 2).
7. Replace five lug nuts and tighten, making sure lug nuts are very tight.
8. Raise cylinder to raise machine off of blocks. Remove blocks and lower machine.
9. Repeat to other side if necessary.

REPLACE CASTER

Keep clean and free of debris; ensure it can move freely.

1. Give a shot of grease in grease fitting on caster every month to keep caster moving freely.
2. To remove caster, machine will need to be raised. Push the cylinder lift lever forward to lower and adjust the angle of the cutting head to jack up the machine. Block up machine with wooden block. Remove four bolts, pull caster off and clean/replace as needed.
3. Replace caster.
4. Pull caster toward rear of machine; re-place and tighten the four bolts.
5. Lower the machine.

CLEAN AIR CLEANER FOAM ELEMENT

Wash the element in detergent and water and dry thoroughly.

CLEAN AIR CLEANER PAPER ELEMENT



CAUTION: DO NOT USE PETROLEUM SOLVENT TO CLEAN PAPER ELEMENT. DO NOT OIL PAPER ELEMENT. DO NOT USE PRESSURIZED AIR TO CLEAN OR DRY PAPER-ELEMENT.

Clean the paper element by tapping it gently against a flat surface to remove the dust. If the element is very dirty replace it with a new one.

Note: When operating in dusty conditions engine may require more frequent maintenance.

REPLACE AIR CLEANER

1. Remove the wing bolts, washers, and air cleaner case.
2. Remove the air cleaner elements from the body.
3. Install the elements and the air cleaner parts correctly on the air cleaner body.

CHECK ENGINE OIL

Check dip stick on engine. Engine holds 1.75 qt of oil. Improper fluid level will cause engine damage. See Kawasaki manual to change oil.

CHANGE ENGINE OIL AND FILTER



CAUTION: STOP THE ENGINE. BE CAREFUL WITH HOT OIL.

1. Follow shut-down procedure.
2. Lift hood and secure in place.
3. Remove cap from engine oil hose. Drain.
4. Remove engine oil filter.
5. Coat a film of clean engine oil on seal of new filter.
6. Install new filter rotating clockwise until the seal contacts the mounting surface. Rotate filter 3/4 of a turn more by hand to fully tighten down.
7. Replace engine oil.
8. Run the engine for around 3 minutes, stop engine and check for oil leaks around the filter.

CLEAN AND REGAP SPARK PLUG



CAUTION: BEFORE PERFORMING MAINTENANCE ON SPARK PLUG STOP THE ENGINE AND ALLOW TO COOL.

1. Disconnect the spark plug wire lead and remove the spark plug.
2. Scrape or use a wire brush to clean the electrodes and remove carbon deposits and wetness.
3. Inspect for cracked porcelain or other wear or damage. Replace the spark plug with a new one if necessary.
4. Check the spark plug gap and reset it if necessary. The gap must be between 0.7 and 0.8 mm. To change the gap, bend only the side electrode using a spark plug tool.
5. Install and tighten the spark plug to 17 ft-lb torque.
6. Reconnect the spark plug lead.

Maintenance



CAUTION: THE BACKUP BEEPER IS ON THE MACHINE FOR SAFETY. IT IS IMPORTANT TO KEEP IT IN GOOD WORKING CONDITION. FAILURE TO DO SO COULD CAUSE BODILY INJURY.

SEAT REPLACEMENT

1. Rotate hood to bumper stops.
2. Remove four nuts securing seat rails.
3. Replace seat; screw on nuts.

REMOVE/REPLACE FOOT PEG

1. Insert a socket wrench into foot peg and secure bolt head.
2. Remove nut.
3. Remove bolt and foot peg.
4. Replace foot peg before operating machine. Do not operate machine without foot pegs.

TELEMATICS OPTION (8000-12XXXX)

Part No.	Description
406271	Harness, Telematics, Hood, Ride-On, Propane
406273	Harness, Telematics, Body, Ride-On, Propane
406275	Fuse, 3A, 250VAC / 58VDC
406277	Module, Telematics, M7-LITE, ZTR
406278	Mount Kit, Telematics, M7-LITE, ZTR

If you have issues with 406271, 406273 or 406275, please call National's Technical Support.

If you have issues with 406277 or 406278, please call your sales rep.

Parts List and Diagrams

EXTERNAL PARTS

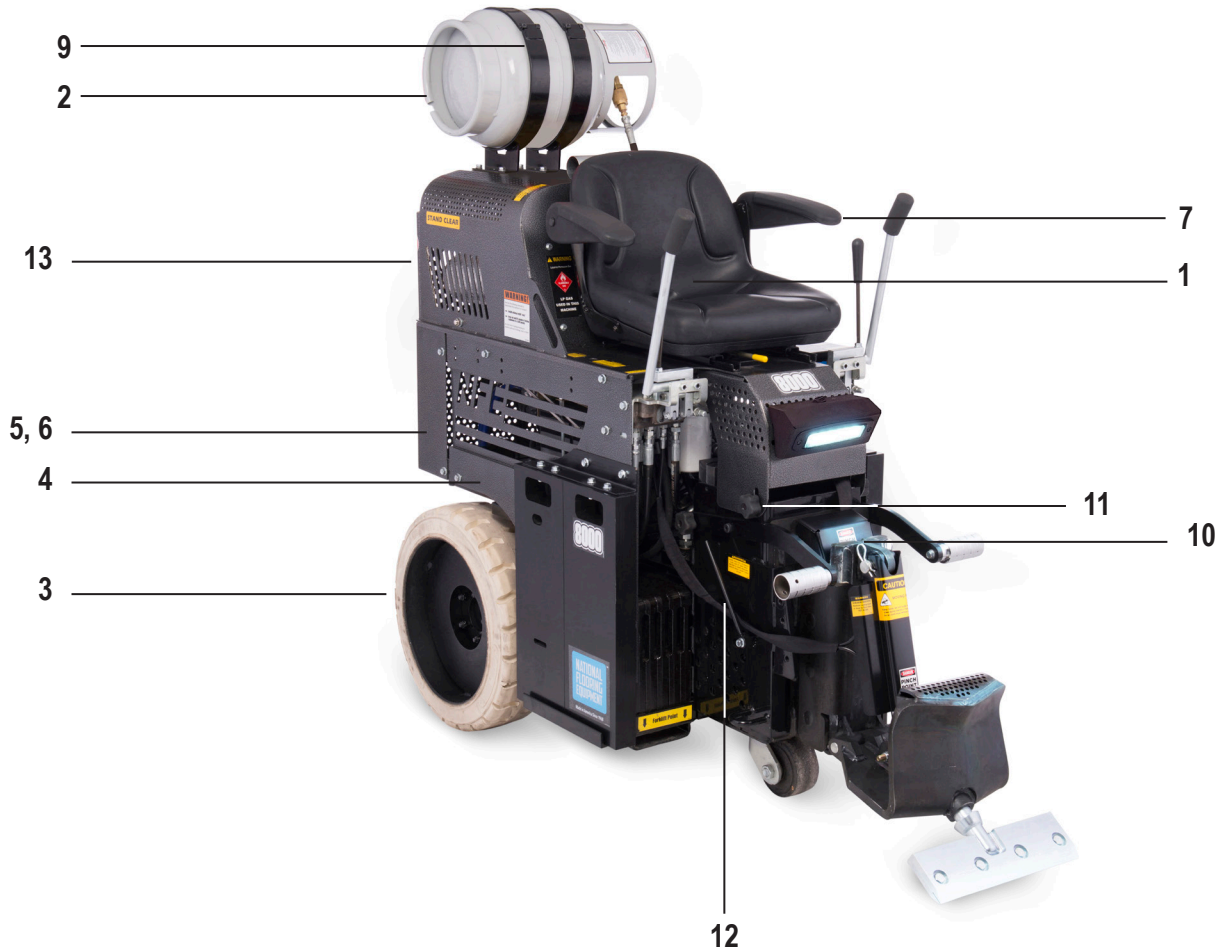

PART#	DESCRIPTION	QTY	PART#	DESCRIPTION	QTY
1	5110-111 SEAT, RIDE-ON	1	7	400321 ARMRESTS, KIT FOR PLASTIC SEAT	1
2	402139 TANK, PROPANE, 20LBS	1	8	401561-SV PANEL, SIDE, LEFT, SILVER VEIN (NOT SHOWN)	1
3	401697 WHEEL, HD, 21"	2		401561-G PANEL, SIDE, LEFT, GREEN (NOT SHOWN - 8000-12XXXX ONLY)	1
4	401560-SV PANEL, SIDE, RIGHT, SILVER VEIN	1	9	70628 BRACKET SET, TANK, 33 POUND, LP	1
	401560-G PANEL, SIDE, RIGHT, GREEN (8000-12XXXX ONLY)	1	10	401669 COVER, UPPER HOSE	1
5	404304-SV HINGE, LOWER, BOLT-ON, LOWER WRAP, SIVER VEIN	2	11	401999 KNOB, THREE-LOBE 1/2-13	2
	404304-G HINGE, LOWER, BOLT-ON, LOWER WRAP, GREEN (8000-12XXXX ONLY)	2	12	5200-603 HOSE GUIDE	1
6	404303-SV SHROUD WELDMENT, LOWER WRAP, BOLTED HINGE, SIVER VEIN	1	13	403132-SV HOOD WLDT, RIDE-ON, SILVER VEIN	1
	404303-G SHROUD WELDMENT, LOWER WRAP, BOLTED HINGE, GREEN (8000-12XXXX ONLY)	1		403132-G HOOD WLDT, RIDE-ON, GREEN (8000-12XXXX ONLY)	1

Parts List and Diagrams

MOTOR POD ASSEMBLY

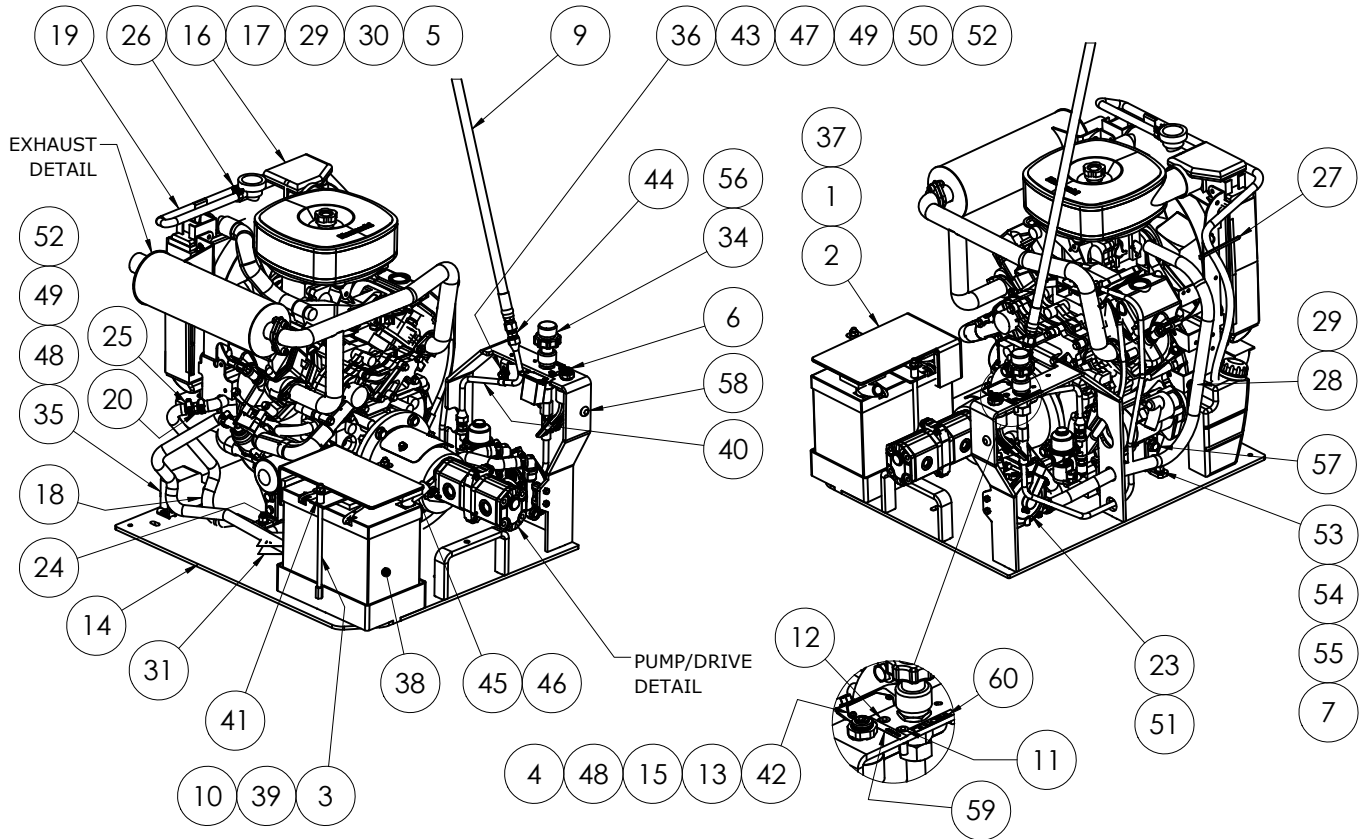

ITEM NO.	PART NO.	DESCRIPTION	QTY.
1	400191-1	Cover, Battery, Top	1
2	400280	Barrier, Heat, Adhesive Back	1
3	401418	Rod, Threaded, 5/16-18x9	2
4	401496	Screw, Hex Head Cap, 1/4-20 x 3/8, Clear Zinc	1
5	402109	Bolt, Motor Base, M10 x 25 w/patch	4
6	402367	Switch, Ignition, Keyed, Sealed, Quick Connect	1
7	402803	Bracket, Motor, Torque Control	4
8*	403217	Harness, Wiring, Motor Pod, Oil Pressure	1
9	403219	Hose, LPG, Top-Mount	1
10	404157	Nut, Keps, 5/16-18, Clear Zinc	2
11	403300	Light, LED, 8mm, Red, 12v, 20mA	1
12	403301	Light, LED, 8mm, Green, 12V, 20mA	1
13	403607	Screw, Button Head Cap, 4-40 x 3/8, Clear Zinc	2
14	404121	Weldment, Base, Motor Pod, Forward Ignition	1
15	404122	Bracket, Meter, Hour, Propane	1
16	400130	Engine, 25HP, Kawasaki	1
17	400144	Fan, Reverse, 25 HP	1
18	400158	Hose, Coolant, 1/2 ID, Silicone	1
19	400167	Hose, Coolant, 1/4 ID, Silicone	1
20	400181	Fitting, Splice, 1/2 ID Hose, Barbed, Brass	1
21*	402377	Oil, Motor 5W-30	1
22*	403220	Propane Kit	1
23	403306	Regulator, Propane, 4psi	1
24	5600-131	Drain Kit, Engine Oil	1
25	70605	Clamp, Hose, Worm Gear, 1/2	6
26	70656	Clamp, Hose, Mini, 13.5mm	1
27	72840	Tie, Cable, Black Nylon, 18lbs, 4"	3
28	73027	Bolt, Wizlock, 1/4-20 X 3/4	1
29	73091	Washer, Flat, Zinc, SAE 1/4	9
30	74630	Bolt, Hex Head Cap M6-12 8.8	4
31	L290	Label, Oil Change Plug	1
32*	404137	Cable, Battery, Red, 32"	1

ITEM NO.	PART NO.	DESCRIPTION	QTY.
33*	404138	Cable, Battery, Black, 24"	1
34	404143	Assembly, Cable, Throttle, Motor Pod	1
35	5200-116	Beeper, Back-up	1
36	5200-217	Bracket, Clamp, Hose	1
37	5200QL-28A	Foam, Battery Cover, 2" x 8"	5
38	5600-121	Battery, 12 Volt, 55 AGM	1
39	5600-13	Bracket, Hold Down, Battery	1
40	5600-68	Line, Fuel, Hard, Top Mount	1
41	5600-83	Spacer, Round, .382 x .500 x .875, Aluminum	2
42	5700-88	Meter, Hour	1
43	63-P30	Clamp, Wire 3/8	1
44	70660	Fitting, Flared	1
45	71703	Protector, Battery Terminal, Red	2
46	71704	Protector, Battery Terminal, Black	1
47	73001	Bolt, Wizlock 1/4-20x1/2	3
48	73002	WASHER, SPLIT LOCK, 1/4	4
49	73005	SCREW, HEX HEAD CAP 1/4-20x1/2	3
50	73009	Nut, Hex, 1/4-20, Grade 2, Clear Zinc	1
51	73020	Bolt, Wizlock 1/4-20x5/8	2
52	73091	Washer, Flat, Zinc, SAE 1/4	3
53	73204	Washer, Lock, 3/8	5
54	73207	Nut, Hex, Nylon Insert, 3/8-16	4
55	73254	Bolt, Flat Head, Socket Cap, 3/8-16 x 1-1/4	4
56	73600	Nut, Hex, 3/4-16, Grade 8, Yellow Zinc	2
57	74650	Bolt, Wizlock, M10-1.5 x 25mm, Class 8.8	2
58	74702	Grommet, 3/8"ID, 3/4"OD 9307K	1
59	L316	Label, Oil Temp On	1
60	L317	Label, Throttle	1
61*	400235	Filter, Oil, 25 HP	
62*	400217	Filter, Foam Element 25 HP	
63*	400218	Filter, Air, Element	

*Not shown

Parts List and Diagrams

PUMP DRIVE ASSEMBLY

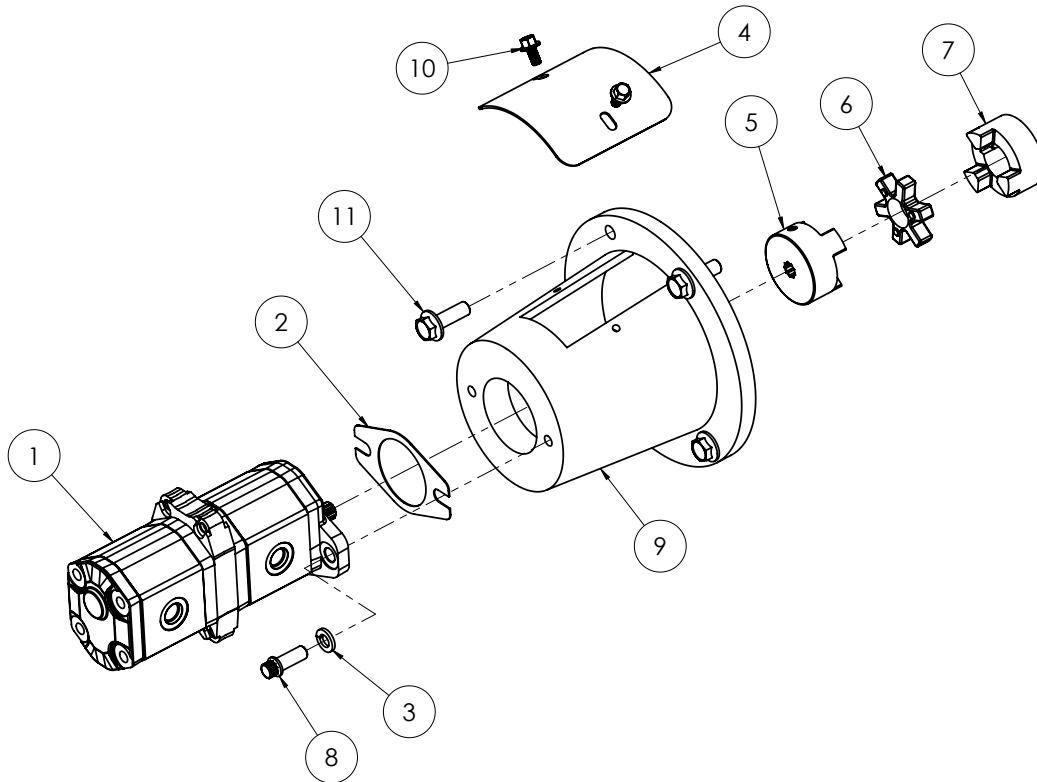

ITEM NO.	PART NUMBER	DESCRIPTION	QTY
1	70905-D7	Pump, Double, Marzocchi	1
2	5200-1G	Gasket, Pump	1
3	73204	Washer, Lock, 3/8	1
4	401414	Cover, Bell Housing	1
5	70951	Coupler, Lovejoy, Splined	1
6	70953	Spider	1
7	70954	Coupler, 1-1/8"	1
8	404156	Screw, Ferry Cap, 3/8-16 x 1, 12pt, Black Oxide	2
9	400179	Housing, Bell Pump, Machined	1
10	73001	Bolt, Wizlock 1/4-20x1/2	2
11	74651	Bolt, Wizlock, M10-1.5 x 30mm, Class 8.8	4

PUMP FITTINGS

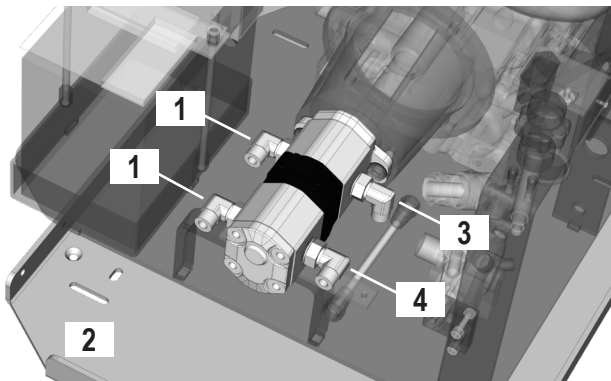

PART#	DESCRIPTION	QTY
1	6280-118 FITTING, SUCTION HOSE TO PUMP	2
2	5200QL-27 BASE, MAIN	1
3	5110-264 FITTING, VALVE, 45 DEGREE	1
4	72816 FITTING, ELBOW, 90 DEGREE, 3/8"	1

Parts List and Diagrams

EXHAUST ASSEMBLY

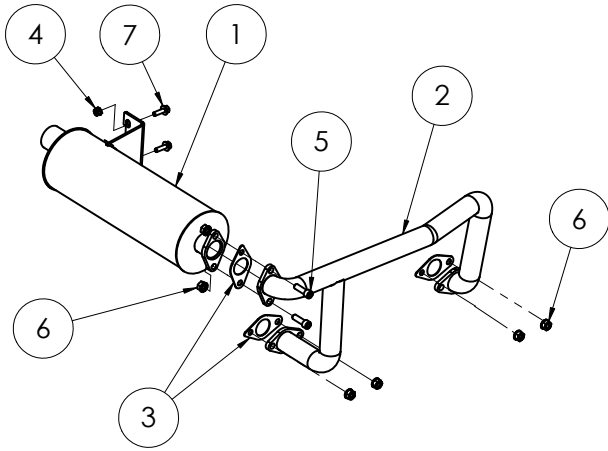

ITEM NO.	PART NO.	DESCRIPTION	QTY.
1	404285	Muffler, Exhaust, 25hp, Foil Wrapped, Flanged	1
2	404286	Manifold, Exhaust, 25hp, Foil Wrapped, Flanged	1
3	400219	Gasket, Muffler	3
4	403235	Nut, Keps, M6-1.0, Clear Zinc	2
5	73311	Screw, Socket Head Cap, 5/16-18x1	2
6	404157	Nut, Keps, 5/16-18, Clear Zinc	6
7	74632	Bolt, Wizlock, M6-1.0x20, Clear Zinc	2

TOP-MOUNT FUEL LINE



ITEM NO.	PART NUMBER	DESCRIPTION	QTY.
1	403219	Hose, LPG, Top-Mount	1

Parts List and Diagrams

SUCTION ASSEMBLY

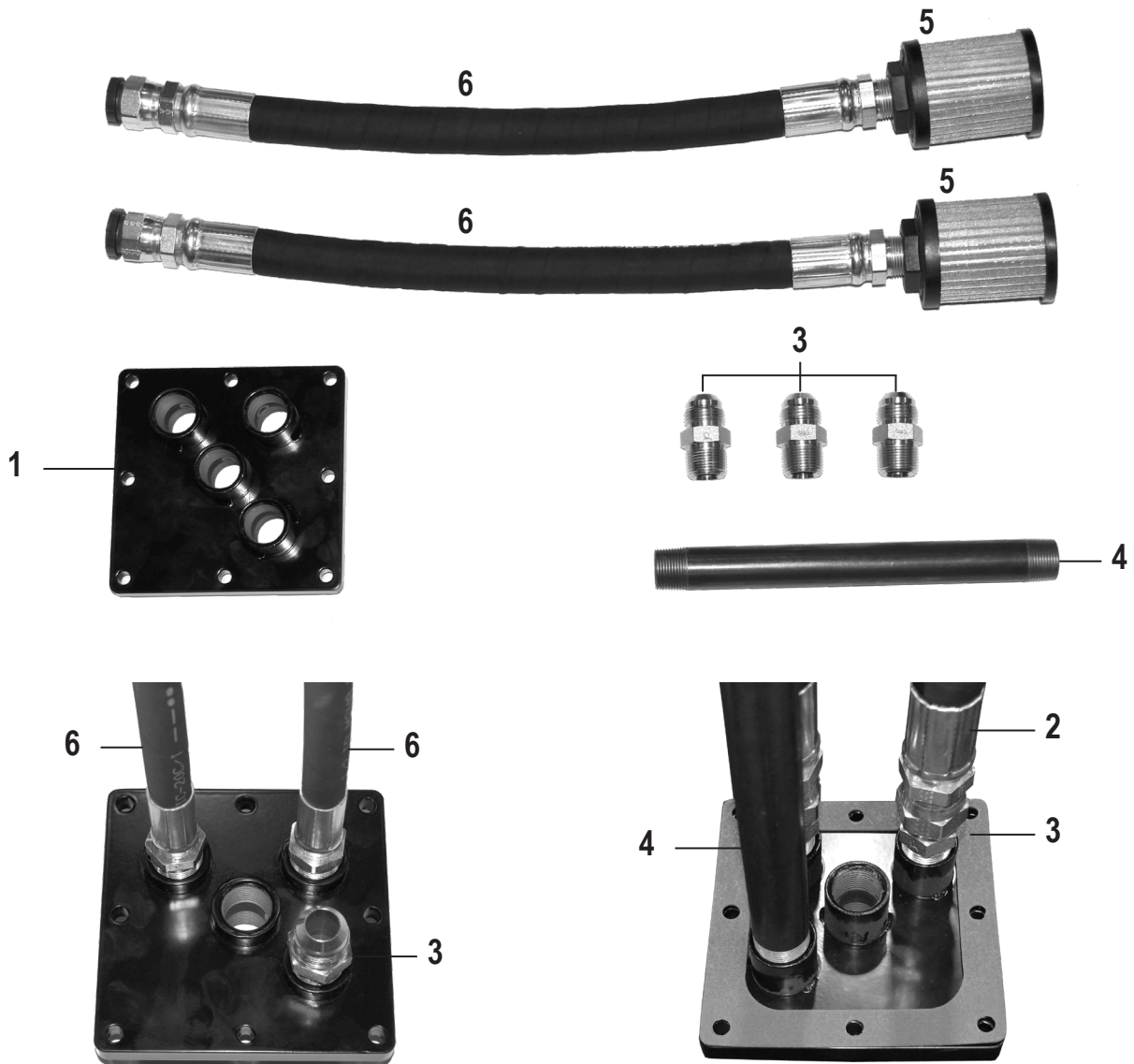

PART#	DESCRIPTION	QTY	PART#	DESCRIPTION	QTY		
1	401574	PLATE, SUCTION	1	4	70655	PIPE, MALE, 10" X 3/4"	1
2	5700-93	GASKET	1	5	5110-237	FILTER SCREEN	2
3	70652	FITTING	3	6	400099	HOSE, HYDRAULIC, SUCTION, 3/4X20, F/M2	

Parts List and Diagrams

LEVERS

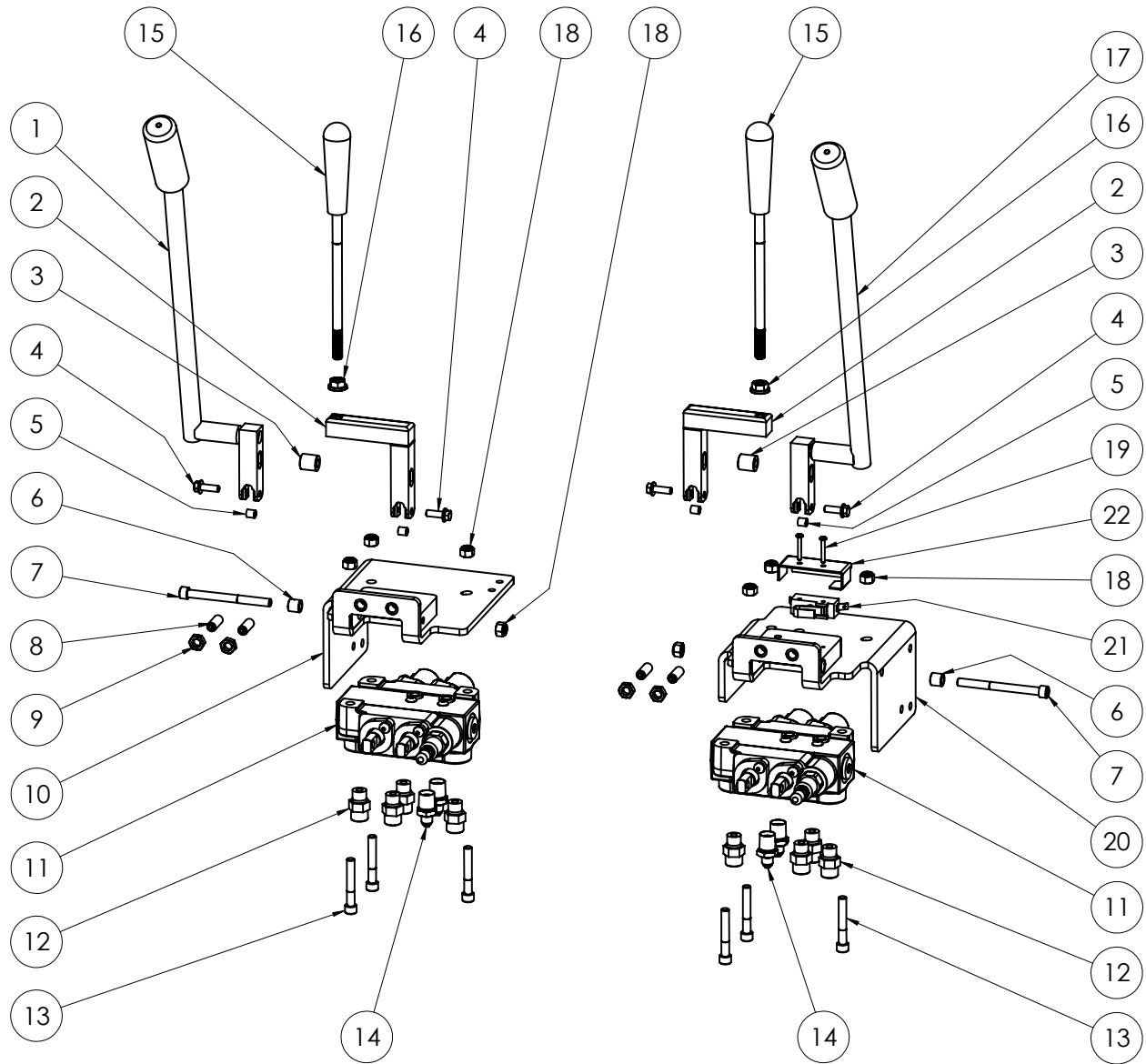

ITEM NO.	PART NUMBER	DESCRIPTION	QTY.	ITEM NO.	PART NUMBER	DESCRIPTION	QTY.
1	402416	Assembly, Valve Handle, Right	1	12	70651	Plug, Valve Body	8
2	401797	Bracket, Universal, Lever	2	13	73320	Bolt, Socket Head Cap 5/16-18x2	6
3	401408	Spacer, Round, .323 X .625 X .675	2	14	5110-268	Fitting, Valve Straight	4
4	73027	Bolt, Wizlock, 1/4-20 X 3/4	4	15	5700-60	Handle, Valve Adjustment	2
5	401604	Bushing, Lever, Hydro Valve	4	16	73211	Nut, Flange, Serrated, 3/8-16	2
6	402227	Sleeve, Take-up, Valve Brkt	2	17	402415	Assembly, Valve Handle, Left	1
7	73321	Bolt, SHCS, 5/16-18x3.5	2	18	73322	Nut, Nyloc, 5/16-18	8
8	73227	Screw, Set 3/8-24x1	4	19	74517	Screw, PPH-MS, 6-32x1	2
9	73235	Nut, Hex Jam 3/8-24	4	20	401795	Bracket Wldt, Valve, LH	1
10	401796	Bracket Wldt, Valve, RH	1	21	403064	Switch, Back-up Beeper	1
11	401834	Valve, Metered, Dual Spool, High PSI	2	22	402949	Cover, Switch, Back-Up	1

Parts List and Diagrams

DUAL SLIDE PLATE

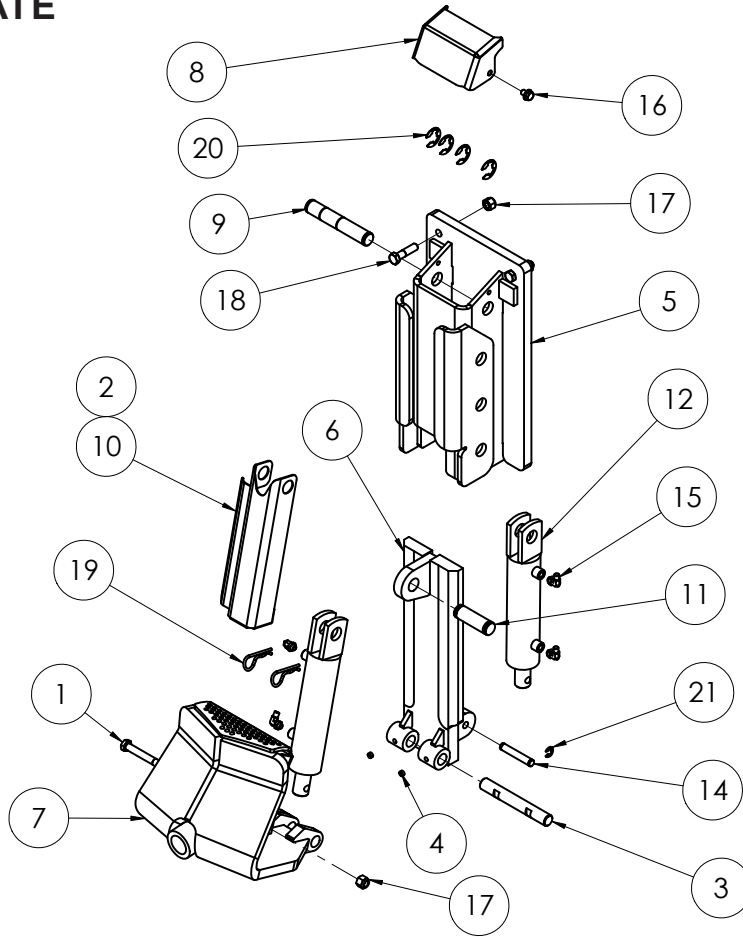

ITEM NO.	PART NO.	DESCRIPTION	QTY.
1	400132	Bolt, Hex Head, 1/2-13 x 4, Grade 8	1
2*	400296	Gasket, EPDM Foam	1
3	401429	Pin, Lower Cutting Head Support	1
4	401876	SSS, 3/8-24 x .25, Black Oxide	2
5	402423	Housing, Hydraulic Adjustment, Wldt	1
6	402432	Slide Plate, Hydraulic Adjustment, Wldt	1
7	402440	Tooling Holder, Weldment	1
8	402513	Cover, Hydraulic Adjustment, Housing	1
9	402542	Pin, Upper, Hydraulic Cylinder	1
10	402574	Shield, Cylinder	1
11	402576	Pin, Cylinder/Guard, Upper	1
12	5110-250	Cylinder NN16	2
13*	401633	Hose, Assembly, Hydraulic, 1/8 x 31.75, F/F, 6KSI	2
14	6500-31	Pin Lower Middle	1
15	72801	Fitting, 90 Deg., 1/4"	4
16	73224	Bolt, Wizlock, 3/8-16x1/2	2
17	73402	Nut, Nylock, 1/2-13	3
18	73413	Bolt, Hex Head 1/2-13x2	2
19	73536	5/8 Hitch Pin Clip	2
20	80083	E-Clip, 1" shaft	4
21	80084	E-Clip, 1/2" shaft	2

*Not shown

Parts List and Diagrams

WHEEL MOTOR (2X)

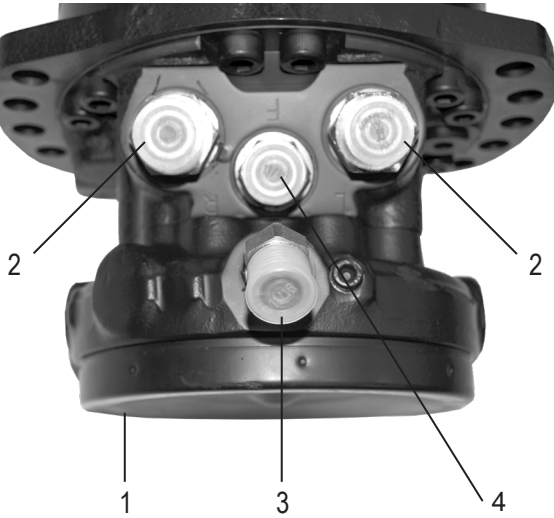

	PART#	DESCRIPTION	QTY
1	401592	WHEEL MOTOR, POCLAIN W/ BRAKE	1
2	5110-114-2	FITTING, WHEEL MOTOR	2
3	5110-264	FITTING, VALVE, 45 DEGREE	1
4	400034	FITTING, FF1231-0608	1

WHEEL MOTOR HOSES (2X)

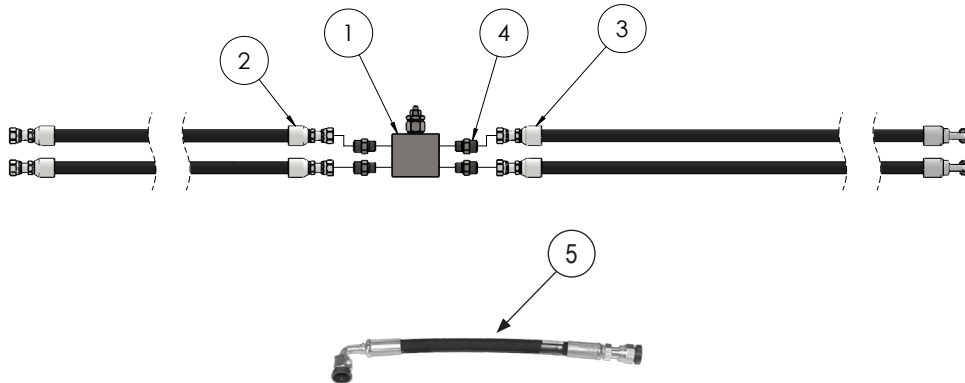

Item#	Part#	Description	QTY
1	405050	Manifold, Relief, Crossover, Hydraulic, 3000 PSI	1
2	405053	Hose, Hydraulic, 3/8 x 19", F/F, 5KSI	2
3	405054	Hose, Hydraulic, 3/8 x 34.25", F/90F, 5KSI	2
4	70651	Fitting, Adapter, Male ORFS-06 x Male UNO-06	4
5	5700-75	Hose, Hydraulic, 3/8 x 13, F/90F	1

Parts List and Diagrams

HYDRAULIC PARKING BRAKE



PART#	DESCRIPTION	QTY	
1	402154	FITTING, #12 O-RING BOSS TO #1	1
2	402199	FITTING, #4 O-RING BOSS TO #6	2
3	5700-65	FILTER	1
4	401972	BRACKET, VALVE BLOCK	1
5	401973	HOUSING, HYDRAULIC, ASSEMBLY	1
6	400034	FITTING, FF1231-06-08 (NOT SHOWN)	2
7	402205*	HOSE, PARKING BRAKE RELEASE, L	2

* Not shown

BREATHER DIP STICK

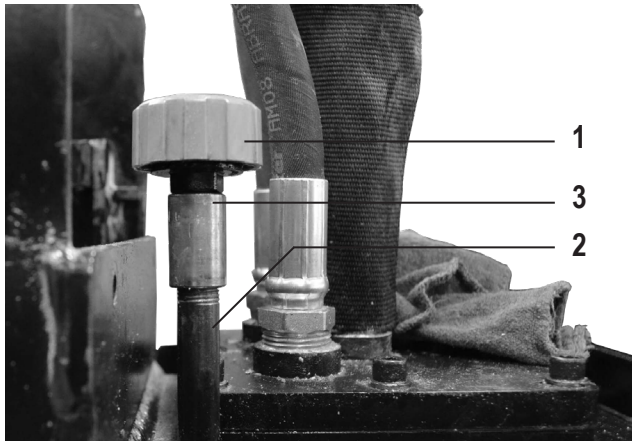

PART#	DESCRIPTION	QTY	
1	405291	BREATHER CAP, WITH SPLASH GUARD, 1/4 NPT	1
2	402989	PIPE, RELIEF VALVE, 2-1/2"	1
3	5110-234	COUPLER, RELIEF VALVE	1

Parts List and Diagrams

DRAIN PLUGS

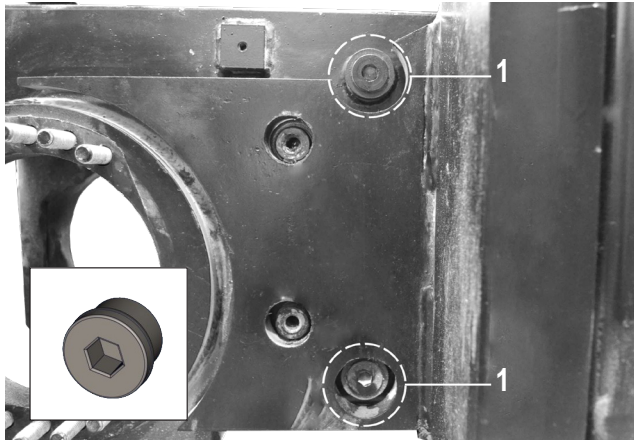

	PART#	DESCRIPTION	QTY
1	5110-157	PLUG, DRAIN-FILLER	2

HOOD SUPPORT

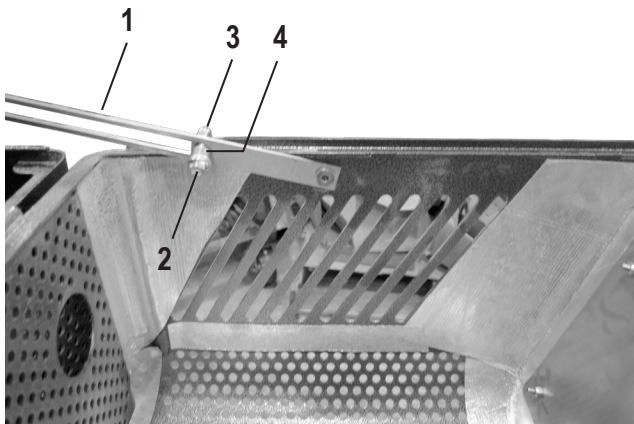

	PART#	DESCRIPTION	QTY
1	400172	SUPPORT, HOOD	1
2	73212	BOLT, BUTTON HEAD CAP, 3/8-16 X .5	1
3	400189	ACORN NUT 3/8-16	1
4	402116	SPACER, HOOD STRAP, HOOD	1
5	401963	SPACER, HOOD STRAP, BODY (NOT SHOWN)	1
6	73223	BOLT, FLANGE 3/8-16 X 1.25 (NOT SHOWN)	1

HOOD BUMPER ASSEMBLY (2X)

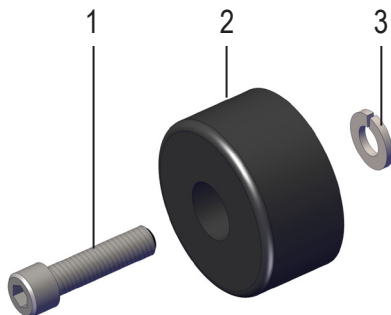

	PART#	DESCRIPTION	QTY
1	73020	BOLT, WIZLOCK 1/4-20X5/8	1
2	5600-66	BUMPER, HOOD	1
3	73002	WASHER, SPLIT LOCK 1/4	1

Parts List and Diagrams

HEAT DEFLECTOR

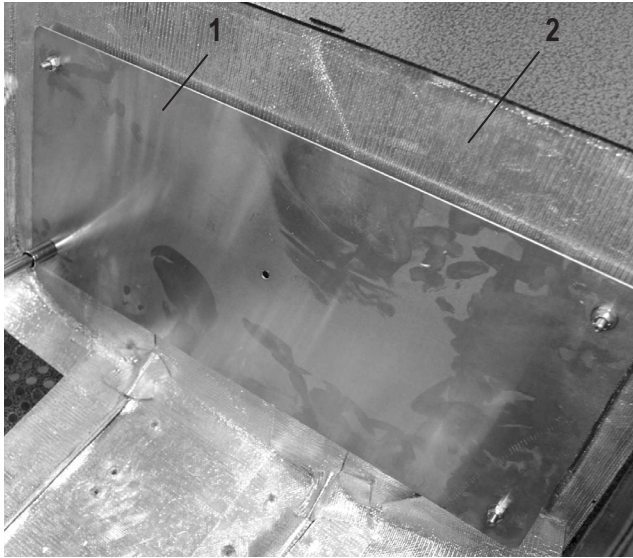

	PART#	DESCRIPTION	QTY
1	5600-80	DEFLECTOR, HEAT	1
2	400280	BARRIER, HEAT, ADHESIVE BACK	5FT

REAR FRAME COVER



	PART#	DESCRIPTION	QTY
1	402177	COVER, FRAME, REAR, XL	1

CASTER WHEEL ASSEMBLY

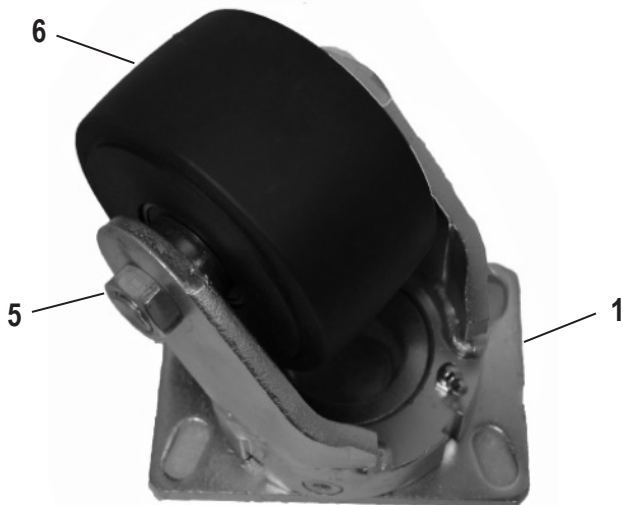

	PART#	DESCRIPTION	QTY
1	401597	CASTER ASSY, HD, KINGPINLESS, 5", PLATE-MOUNT	1
2	73406	BOLT, HEX HEAD CAP 1/2-13X1-1/4 (NOT SHOWN)	4
3	73424	WASHER, FLAT, ZINC SAE 1/2 (NOT SHOWN)	4
4	73403	WASHER, SPLIT LOCK 1/2 (NOT SHOWN)	4
5	403353	AXLE, INCLUDING NUT	1
6	403354	WHEEL, HD, 5"OD X 3-1/2"W	1

Parts List and Diagrams

REMOVABLE WEIGHTS—OUTER AND POCKET

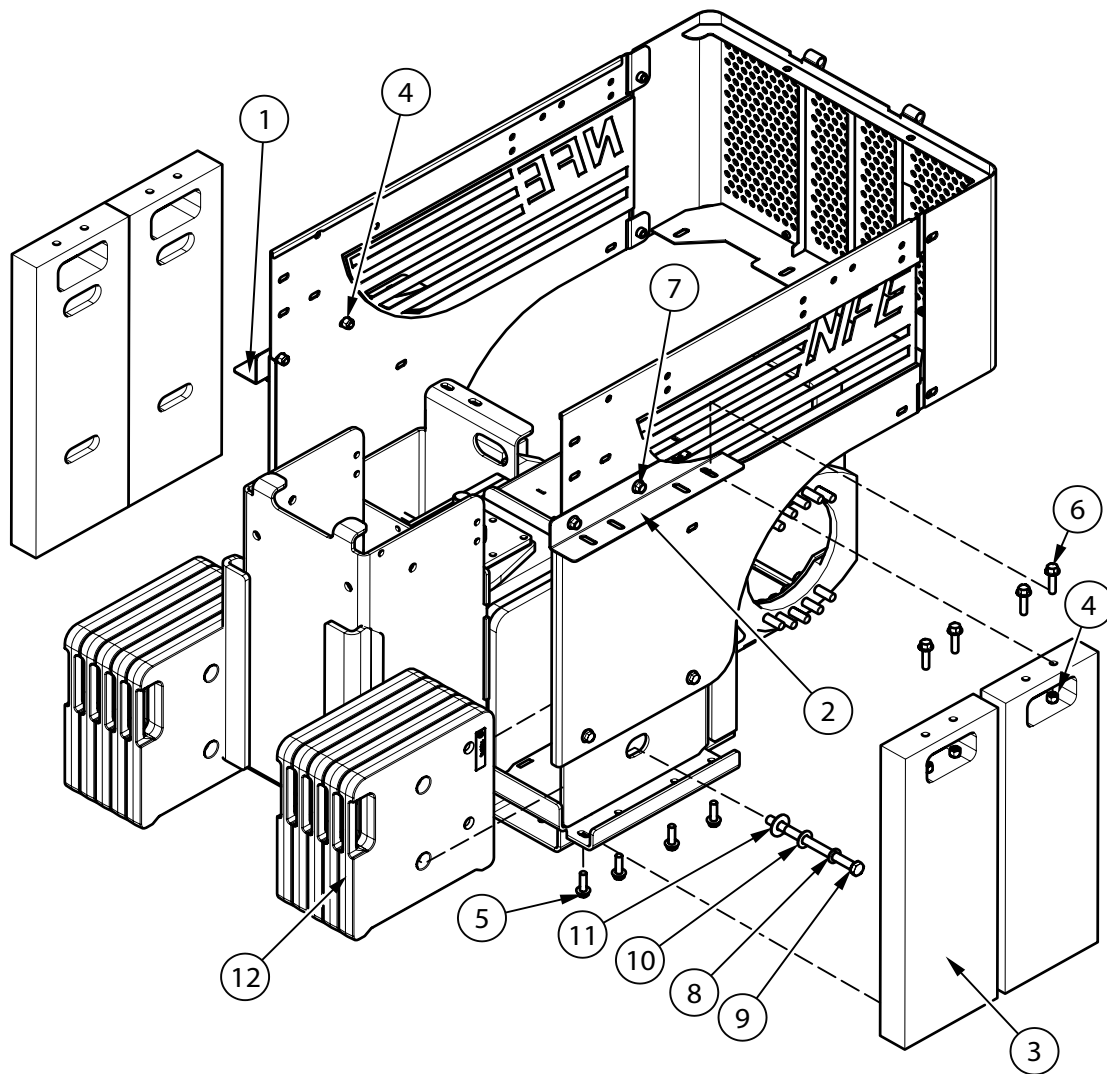

Item No.	Part Number	Description	Qty
1	401961	Bracket, Weight, Right	1
2	401962	Bracket, Weight, Left	1
3	402102	Weight, Outer, XL	4
4	73207	Nut, Hex, Nylon Insert, 3/8-16	12
5	73223	Bolt, Wizlock, 3/8-16x1-1/4	8
6	73238	Bolt, Wizlock, 3/8-16x1-1/2	8
7	73259	Bolt, Wizlock, 3/8-16X3/4	4
8	73403	Washer, Split lock 1/2	2
9	73414	Bolt, HHCS, 1/2-13x 7	2
10	73424	Washer, Flat, Zinc SAE 1/2	2
11	73425	Washer, Flat USS Zinc 1/2	2
12	74854	Weight, Pocket, Cast, Ride On	10

Parts List and Diagrams

REMOVABLE WEIGHTS—FRONT AND REAR

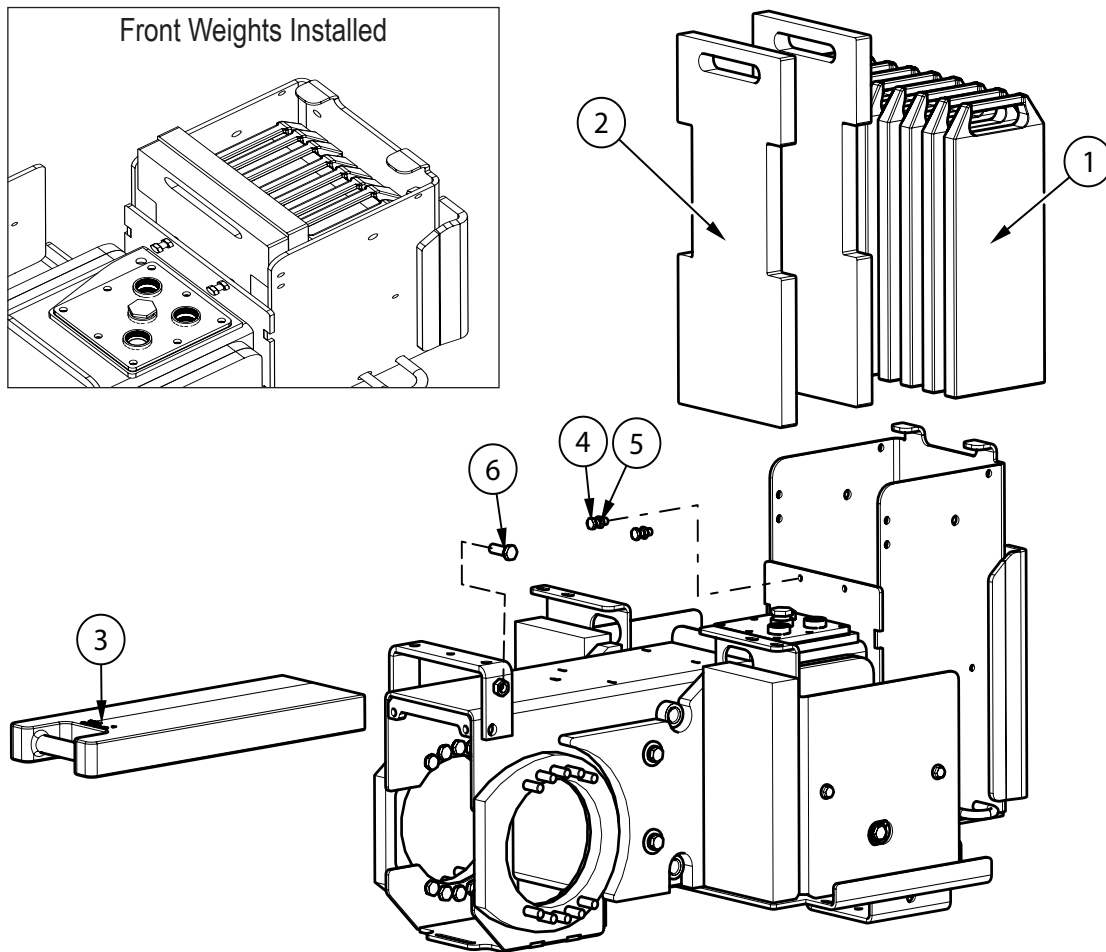

Item No.	Part Number	Description	Qty
1	400197	Weight, Front, 16.5 X 6.88	9
2	402137	Weight, Front Take-Up	2
3	5110-404	Bottom Weight	1
4	73201	Screw, Hex Head Cap, 3/8-16 x 1	2
5	73229	Nut, Hex Jam 3/8-16	2
6	73427	Bolt, Hex Head Cap 1/2-13x1-1/2	1

Parts List and Diagrams

SEAT ADJUSTER

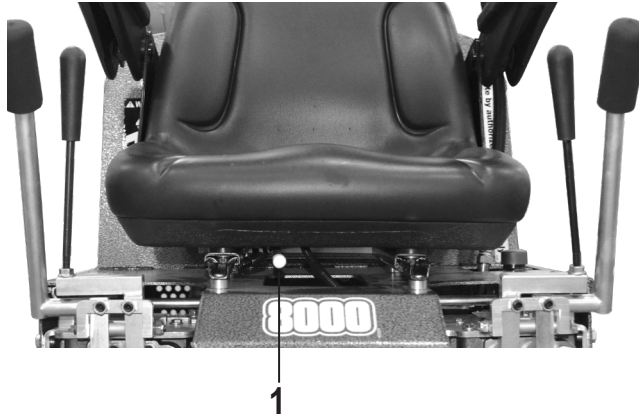

	PART#	DESCRIPTION	QTY
1	401631	ADJUSTER, FORE/AFT, SEAT	1

SEAT SWITCH

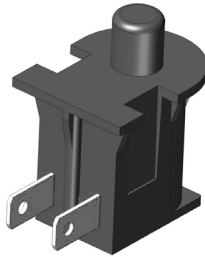

	PART#	DESCRIPTION	QTY
1	5110-207	SWITCH, SEAT	1

FOOT PEGS (2X)

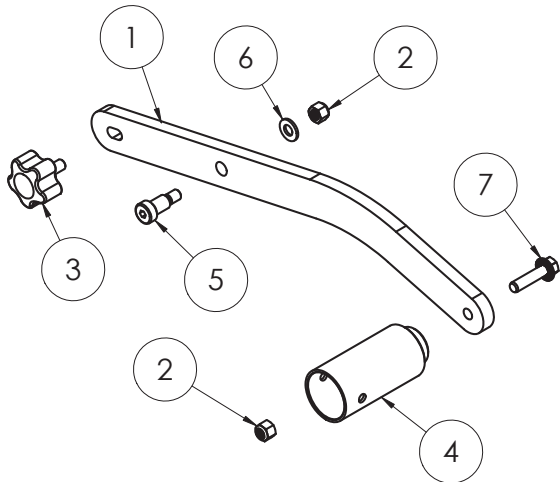

ITEM NO.	PART NUMBER	DESCRIPTION	QTY.
1	402298	Bracket, Pivot, Footrest	1
2	73207	NUT, NYLOCK, 3/8-16	2
3	401999	Knob, Adjustable, 3/4"	1
4	5110-180	Peg, Foot	1
5	402460	Bolt, Shoulder, .500 x .75, 3/8-16	1
6	73263	WASHER, FLAT SAE ZINC 3/8	1
7	73238	Bolt, Flange 3/8-16x1-1/2	1

Parts List and Diagrams

INSTRUCTION TUBE PARTS

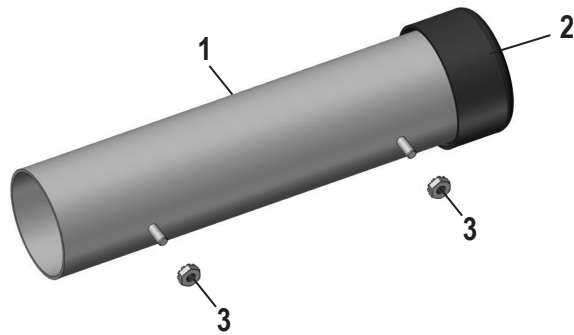

	PART#	DESCRIPTION	QTY
1	70602	INSTRUCTION MANUAL TUBE	1
2	70603	INSTRUCTION TUBE CAP	1
3	74425	NUT, KEPS LOCK 10-32	2

BACKUP BEEPER ASSEMBLY



	PART#	DESCRIPTION	QTY
1	5200-116	BEEPER, BACK UP	1

HEADLIGHT ASSEMBLY

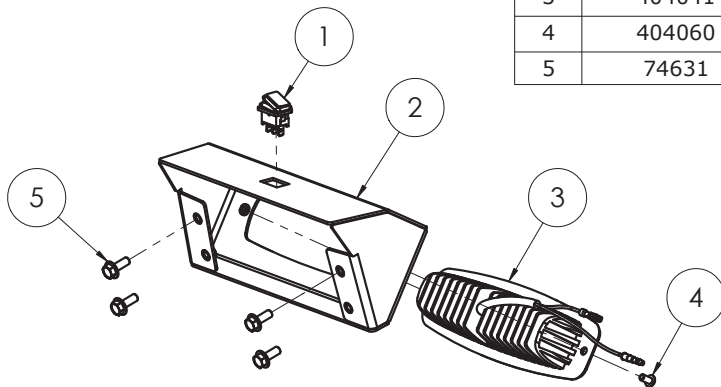
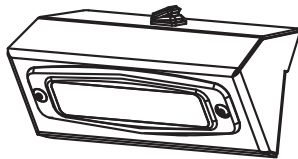

ITEM NO.	PART NUMBER	DESCRIPTION	QTY
1	403976	Switch, Rocker, SP, 14V, 16 A	1
2	404009	Shroud, Worklight, Rider, Low Profile	1
3	404041	Light, Work, 6"x2", Flush, 18W	1
4	404060	Screw, Button Head Cap, M5x0.8x10, Black Oxide	2
5	74631	Bolt, Wizlock, M6-16	4

Parts List and Diagrams

BEACON ASSEMBLY 402512 (8000-33XXXX ONLY)

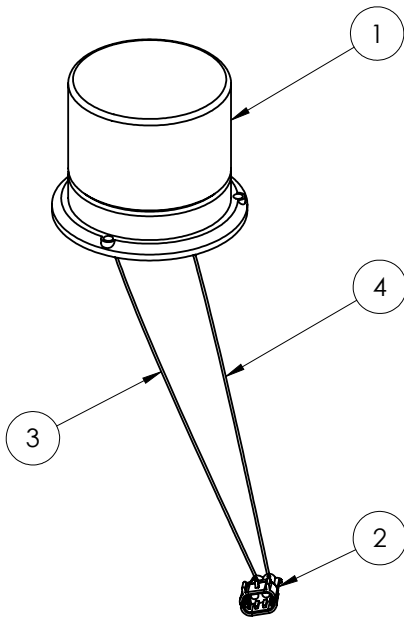

ITEM NO.	PART NUMBER	DESCRIPTION	QTY.
1	70629	Light, Flashing	1
2	72790	Connector, Male, 2 Pole	1
3	72568	Wire, Primary, 14 GPT-500-RED (TSC)	3'
4	72569	Wire, Primary, 14 GPT-500-BLK (TSC)	3'
5	72770	Terminal, 14-12 Gauge, Male	2 *
6	72775	Terminal, 18-16 Gauge, Female	2 *
7	72815	Terminal Connector, Female, Push-On	1 *
8	72836	Terminal, Nylon, B, Butt, 16-14	2 *
9	72873	Clamp, Cable 3/8	2 *
10	72887	Loom, Convoluted Split 1/2"	3.5' *
11	72892	Lock, Secondary, TPA, 2 Pole	1 *
12	72931	Seal, Cable	1 *
13	73222	Screw, Hex Head Cap, Flange, 3/8-16 x 1	4 *

* - NOT SHOWN

LIGHT AND TANK BRACKET ASSEMBLY (8000-33XXXX ONLY)

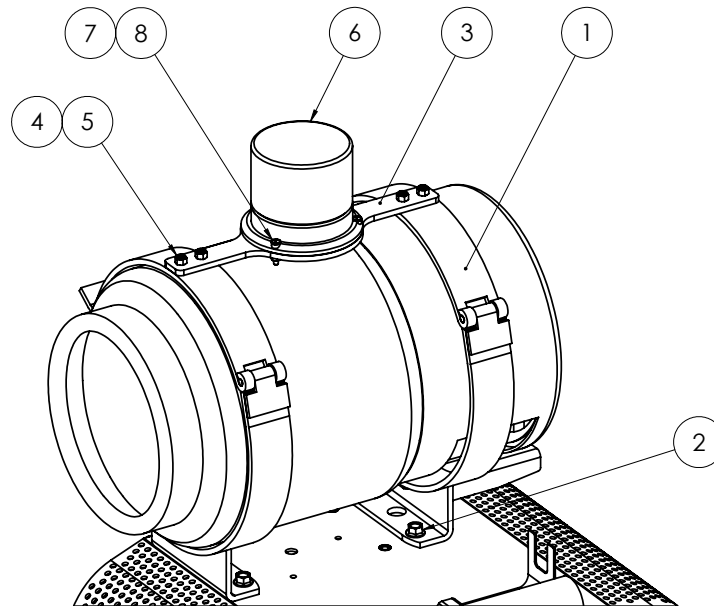

PART#	DESCRIPTION	QTY	PART#	DESCRIPTION	QTY		
1	402136	BRACKET, TANK, 33 POUND, LP, MOD	1	5	73008	NUT, NYLOCK 1/4-20	4
2	73259	BOLT, FLANGE, SERRATED, SAE 3/8-16X3/4	4	6	402512	ASSEMBLY, BEACON, WIRED	1
3	402105	BRACKET, LIGHT, AUS	1	7	74430	SCREW, PHILLIPS PAN HEAD MACHINE, ZINC 10-32X3/4	3
4	73029	SCREW, FLAT HEAD SOCKET CAP, 1/4-20 X 3/4, BLACK OXIDE	4	8	74425	NUT, KEPS LOCK 10-32	3

Parts List and Diagrams

LABELS

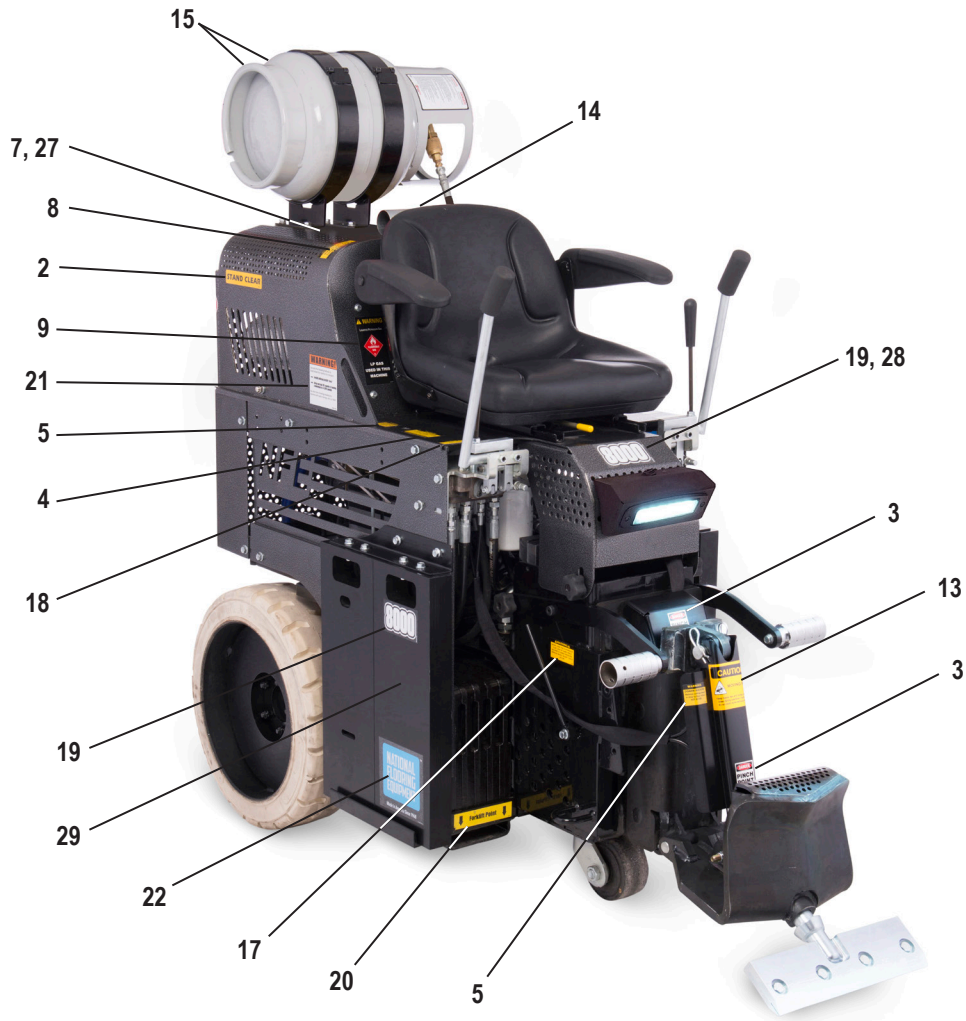

PART#	DESCRIPTION	QTY	PART#	DESCRIPTION	QTY
1	405190-XX**	1	17	L95F	2
2	L08-1	2	18	L98	2
3	L106	2	19	402059	3
4	L118	2	20	402149	2
5	L137	3	21	402376	1
6	L142*	1	22	402464	2
7	L155	1	23	L223*	1
8	L256	2	24	L290***	1
9	L314	1	25	L316***	1
10	L315*	1	26	L317***	1
11	L318*	1	27	404034	1
12	L319*	1	28	402627	1
13	L33B	1		(8000-23XXXX ONLY)	
14	L33C	1	29	402628	2
15	L561	2		(8000-23XXXX ONLY)	
16	L66*	1			

* Not shown

** Kit includes Items 2-26. Suffix (-XX) denotes language: None=English.

*** Not shown. See motor pod assembly diagram for label placement.

Wiring Diagrams

8000 MAIN WIRING DIAGRAM

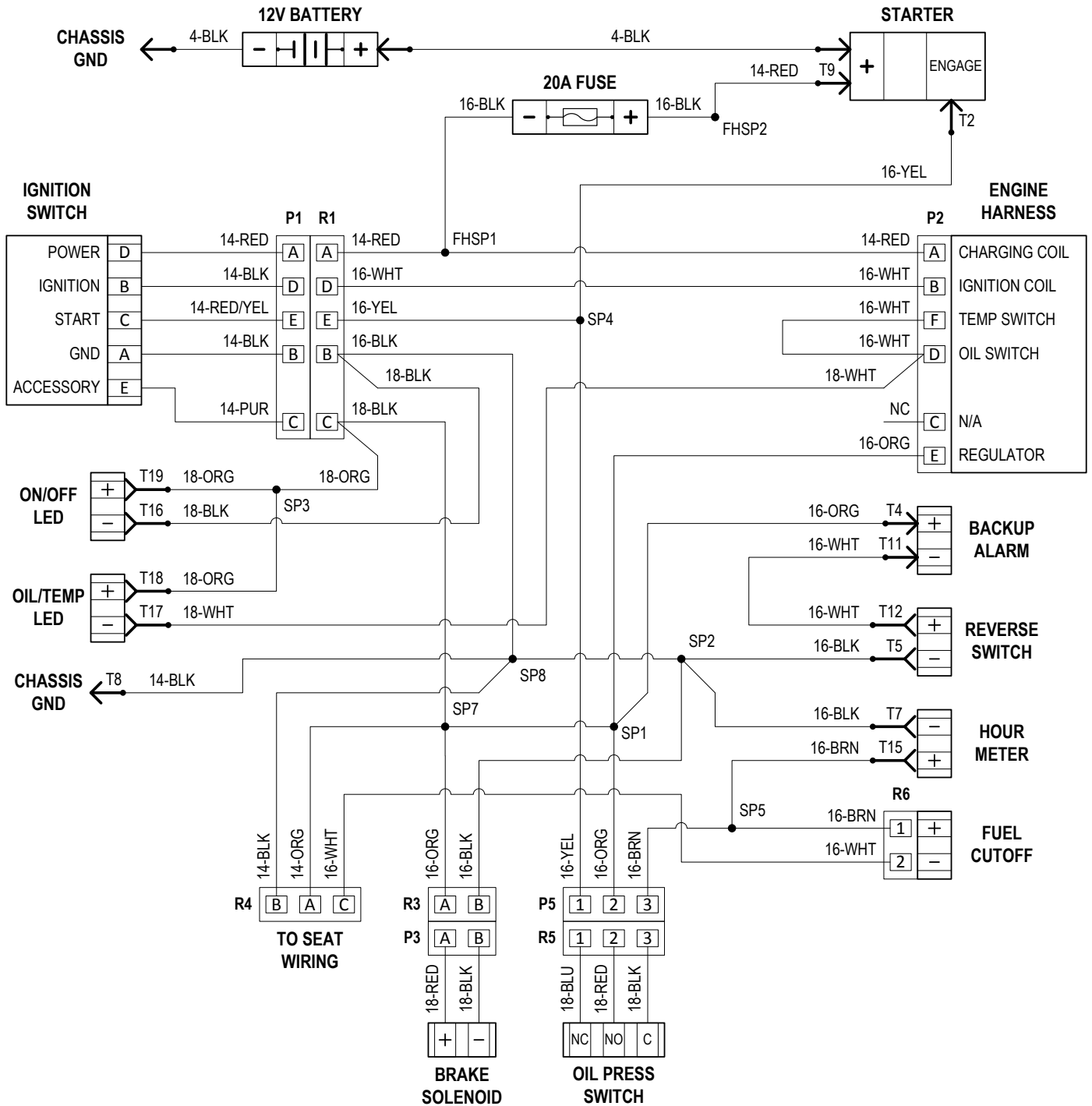

Wiring Diagrams

5625/8000 SEAT WIRING DIAGRAM

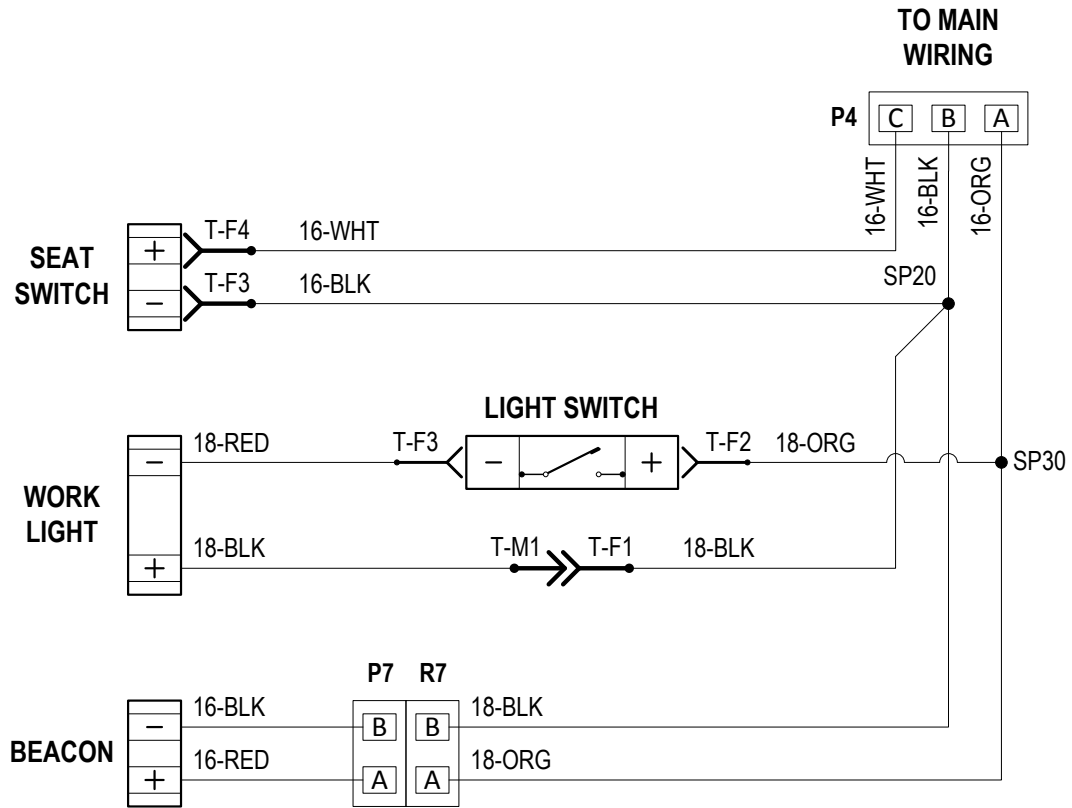

Warranty

National Flooring Equipment Inc. (referred to as "The Company") warrants that each new unit manufactured by The Company to be free from defects in materials and workmanship in normal use and service for a period of twelve (12) months from date of shipment from The Company to the end user. If shipment to end user is from a Distributor, The Company may honor warranty for up to 15 months from initial shipment from the Company if the end user can provide documentation of receipt date. Accessories or equipment furnished and installed on the product by the Company but manufactured by others, including but not limited to: engines, motors, electrical components, transmissions etc., shall carry the accessory manufacturers own warranty. Battery warranties are prorated over the warranty period. Customer is responsible for the inspection of equipment or parts upon delivery. **Freight damages are excluded from this warranty.**

The Company, at its determination of defect, will repair or replace any product or part deemed to be defective in material or workmanship within specified warranty time period. All product determinations and / or repairs will take place at The Company repair facility or at a certified warranty location designated by The Company. The Company will coordinate and be responsible for all freight expenses associated with valid warranty claims. Freight and shipping expenses associated with abuse or misuse will be back charged to the Distributor/Customer. The Company reserves the right to modify, alter or improve any part / parts without incurring any obligation to replace any part / parts previously sold without such modified, altered or improved part / parts. In no event shall the seller or manufacturer of the product be liable for special, incidental, or consequential damages, including loss of profits, whether or not caused by or resulting from the negligence of seller and / or the manufacturer of the product unless specifically provided herein. **This warranty shall not apply to any products or portions there of which have been subjected to abuse, misuse, improper installation or operation, lack of recommended maintenance, electrical failure or abnormal conditions, and to products which have been tampered with, altered, modified, repaired, reworked by anyone not approved or authorized by the Company or used in any manner inconsistent with the provisions of the above or any instructions or specifications provided with or for the product.** Any and all unauthorized onsite warranty work conducted by unauthorized personnel or any outside person(s), is not covered by The Company unless the work has been pre-authorized by a predetermined manufacturer representative. This warranty excludes wearable parts and/or consumables.

Defective or failed material or equipment shall be held at the purchaser's premises until authorization has been granted by The Company to return or dispose of defective products. Products returned to The Company for inspection must be returned with a manufacturer authorized Return Material Authorization (RMA), and must be packaged to The Company's specifications to avoid damage during shipment. Any unauthorized return of equipment will be declined at the dock by The Company. Any non-approved items returned with approved returned items are subject to rejection and will not be credited. Credit will be issued for material found to be defective upon The Company's inspection based on prices at time of purchase.

TO OBTAIN SERVICE CONTACT NATIONAL FLOORING EQUIPMENT, INC. TOLL FREE AT 800-245-0267 FOR A REPAIR AUTHORIZATION NUMBER. COD FREIGHT RETURNS WILL NOT BE ACCEPTED. FREIGHT COLLECT SHIPMENTS WILL NOT BE ACCEPTED. WARRANTY REPAIRS MUST BE ACCOMPANIED BY DATE OF PURCHASE RECEIPT AND A RETURN/ REPAIR AUTHORIZATION NUMBER.

RETURN/REPAIR AUTHORIZATION NUMBER: _____

MACHINE SERIAL NUMBER: _____



Made in America Since 1968

9250 Xylon Avenue N • Minneapolis, MN 55445 • U.S.A.
Toll-free 800-245-0267 • Phone 763-315-5300 • Fax 800-648-7124 • Fax 763-535-8255
Web Site: www.nationalequipmentdirect.com • E-Mail: info@nationalequipment.com