

6280HD GLADIATOR® WALK-BEHIND SCRAPER OPERATING & SERVICE MANUAL



Read Manual Before Operating or
Servicing Machine

401897 Rev K

Table of Contents

Table of Contents	3
Features & Specifications	4
Safety	6
General Rules for Safe Operation	6
Walk-Behind Scraper Safety Guidelines.....	7
Hydraulic Safety.....	8
Electrical Practices	9
Components and Assembly	11
Wheel Modes.....	11
Transport	11
Blades.....	12
Angle Attachments.....	13
Operation	14
Operating Controls.....	14
Start-Up Procedure.....	14
Installing and Adjusting Slide Weights	14
Types of Applications	15
Troubleshooting Guide	16
Maintenance	17
Wheel Cleaner Adjustment	17
Wheel Removal	17
Adding or Changing Hydraulic Fluid	17
Inspection of Internal Parts	17
Tank Removal.....	18
Power Cord.....	18
Isolators	18
Cutting Head Bearing	18
Maintenance Schedule	19
Parts List and Diagrams	20
Overall Machine.....	20
Base Assembly	21
Body.....	22
Weights.....	23
Tank	24
Cutting Head.....	25
Motor Assembly	26
Motor Parts	27
Pump	28
Hydraulic Motor Assembly	29
Eccentric, Chain and Belt	30
Idler Assembly	31
Bottom and Back Covers	32
Wheels.....	33
Transport Wheel Assembly	34
Handle Assembly	35
Front Cover.....	36
Lower Sub-Assembly.....	38
Hydraulic Hoses.....	39
Lever.....	40
Adjustment Rod	41
Speed Control Knob	42
Labels	43
Wiring Diagrams	44
Hydraulics	47
Warranty	48

Features and Specifications



FEATURES

Traction Wheels - Industrial grade self-cleaning wheels that disengage for loading/unloading.

Slide Weights - Applies additional pressure to the scraper head or more traction to the wheels as needed.

Lifting Bail Eyebolts - Eases loading/unloading.

Unique Swivel Head - Provides continuous contact with the floor.

Quick-Adjust Multi-Position Handle - Allows adjustment of handle angle to suit operator or work conditions. Folds flat over machine for storage or transport.

Forward/Reverse Handles - Controls direction of movement.

Speed Control Knob - Limits maximum forward speed.

Features and Specifications

Product Specifications								
Width	Length	Height	Weight (Machine Only)	Weight*	Motor Power	Vibration		
						X Axis	Y Axis	Z Axis
17.8" (45 cm)	49.5" (126 cm) (max. length)	46.8" (119 cm) (max. height)	369 lbs (167.4 kg)	490 lbs (222.3 kg)	1.5 HP (1.1 kW)	3.2 m/s ²	5.1 m/s ²	5.0 m/s ²
	29.5" (75 cm) (handle folded)	30" (76 cm) (handle folded)						

*Includes removable weights.

Machine Variants						
Region	Serial Number	Input Power	Amps (Full Load)	RPM	Max. Speed	Body Panels
Domestic (North America)	6280HD-10XXXX	120V / 60 Hz	13A	1725	30 ft/min	Silver Vein
	6280HD-12XXXX	120V / 60 Hz	13A	1725	30 ft/min	Green
	6280HD-23XXXX	120V / 60 Hz	13A	1725	30 ft/min	Silver Vein
International	6280HD-11XXXX	230V / 50 Hz	8A	1425	13 m/min	Silver Vein
	6280HD-13XXXX	230V / 50 Hz	8A	1425	13 m/min	Silver Vein
	6280HD-20XXXX	110V / 50 Hz	13A	1425	7 m/min	Silver Vein

Safety

GENERAL RULES FOR SAFE OPERATION

Before use, anyone operating or performing maintenance on this equipment must read and understand this manual, as well as any labels packaged with or attached to the machine and its components. Read the manual carefully to learn equipment applications and limitations, as well as potential hazards associated with this type of equipment. Keep manual near machine at all times. If your manual is lost or damaged, contact National Flooring Equipment (NFE) for a replacement.

Personal

Dress properly and use safety gear.

Do not wear loose clothing; it may be caught in moving parts. Anyone in the work area must wear safety goggles or glasses and hearing protection. Wear a dust mask for dusty operations. Hard hats, face shields, safety shoes, etc. should be worn when specified or necessary.

Maintain control; stay alert.

Keep proper footing and balance, and maintain a firm grip. Observe surroundings at all times. Do not use when tired, distracted, or under the influence of drugs, alcohol, or any medication that may cause decreased control.

Keep hands away from all moving parts and tooling.

Wear gloves when changing tooling. Remove tooling when machine is not in use and/or lower cutting head to the floor.

Do not force equipment.

Equipment will perform best at the rate for which it was designed. Excessive force only causes operator fatigue, increased wear, and reduced control.

Environment

Avoid use in dangerous environments.

Do not use in rain, damp or wet locations, or in the presence of explosive atmospheres (gaseous fumes, dust, or flammable materials). Remove materials or debris that may be ignited by sparks. Keep work area tidy and well-lit - a cluttered or dark work area may lead to accidents. Extreme heat or cold may affect performance.

Protect others in the work area and be aware of surroundings.

Provide barriers or shields as needed to protect others from debris and machine operation. Children and other bystanders should be kept at a safe distance from the work area to avoid distracting the operator and/or coming into contact with the machine. Operator should be aware of who is around them and their proximity. Support personnel should never stand next to, in front of, or behind the machine while the machine is running. Operator should look behind them before backing up.

Do not come within 3 ft. of the machine's perimeter during operation.

Guard against electric shock.

Ensure that machine is connected to a properly grounded outlet. Prevent bodily contact with grounded surfaces, e.g. pipes, radiators, ranges, and refrigerators. When scoring or making cuts, always check the work area for hidden wires or pipes.

Maintenance & Repairs

Begin maintenance work only when the machine is shut down, unplugged, and cooled down.

Use proper cleaning agents.

Ensure that all cleaning rags are fiber-free; do not use any aggressive cleaning products.

Schedule regular maintenance check-ups.

Ensure machine is properly cleaned and serviced. Remove all traces of oil, combustible fuel, or cleaning fluids from the machine and its connections and fittings. Retighten all loose fittings found during maintenance and repair work. Loose or damaged parts should be replaced immediately; use only NFE parts.

Do not weld or flame-cut on the machine during repairs, or make changes to machine without authorization from NFE.

Equipment

Use proper parts and accessories.

Only use NFE-approved or recommended parts and accessories. Using any that are not recommended may be hazardous.

Ensure accessories are properly installed and maintained.

Do not permanently remove a guard or other safety device when installing an accessory or attachment.

Inspect for damaged parts.

Check for misalignment, binding of moving parts, loose fasteners, improper mounting, broken parts, and any other conditions that may affect operation. If abnormal noise or vibration occurs, turn the machine off immediately. Do not use damaged equipment until repaired. Do not use if power switch does not turn machine on and off. For all repairs, insist on only identical NFE replacement parts.

Maintain equipment and labels.

Keep handles dry, clean, and free from oil and grease. Keep cutting edges sharp and clean. Follow instructions for lubricating and changing accessories. Motor and switches should be completely enclosed at all times with no exposed wiring. Inspect cord regularly. Labels carry important information; if unreadable or missing, contact NFE for a free replacement.

Avoid accidental starting; store idle equipment.

When not in use, ensure that the machine is unplugged; do not turn on before plugging in. Store in a dry, secured place. Remove tooling when storing, and keep away from children.

WALK-BEHIND SCRAPER SAFETY GUIDELINES

Before use, anyone operating this equipment must read and understand these safety instructions.

Scraping

Beware of hidden obtrusions.

Watch out for hidden dangers and protrusions in flooring. Do not use on largely uneven surfaces.

Observe location of electrical supplies and extension cords.



Do not allow cutting heads to come into contact with any electrical supply or extension cord.

Use correct tooling and accessories.

Provide barriers or shields as needed to protect others from debris. After mounting tooling, check for proper alignment.

Use for correct applications.

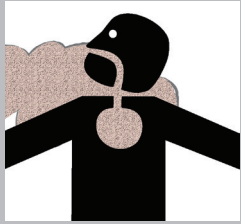
Do not force equipment to do heavier duty work than it was made for.



WARNING: GRINDING/CUTTING/DRILLING OF MASONRY, CONCRETE, METAL AND OTHER MATERIALS CAN GENERATE DUST, MISTS AND FUMES CONTAINING CHEMICALS KNOWN TO CAUSE SERIOUS FATAL INJURY OR ILLNESS, SUCH AS RESPIRATORY DISEASE, CANCER, BIRTH DEFECTS OR OTHER REPRODUCTIVE HARM. IF YOU ARE UNFAMILIAR WITH THE RISKS ASSOCIATED WITH THE PARTICULAR MATERIAL BEING CUT, REVIEW THE MATERIAL SAFETY DATA SHEET AND/OR CONSULT YOU EMPLOYER, THE MATERIAL MANUFACTURER/SUPPLIER, GOVERNMENTAL AGENCIES SUCH AS OSHA AND NIOSH AND OTHER AUTHORITIES ON HAZARDOUS MATERIALS. CALIFORNIA AND SOME OTHER AUTHORITIES, FOR INSTANCE, HAVE PUBLISHED LISTS OF SUBSTANCES KNOWN TO CAUSE CANCER, REPRODUCTIVE TOXICITY, OR OTHER HARMFUL EFFECTS. CONTROL DUST, MIST AND FUMES AT THE SOURCE WHERE POSSIBLE. IN THIS REGARD USE GOOD WORK PRACTICES AND FOLLOW THE RECOMMENDATIONS OF THE MANUFACTURER/SUPPLIER, OSHA/NIOSH, AND OCCUPATIONAL AND TRADE ASSOCIATIONS. WHEN THE HAZARDS FROM INHALATION OF DUST, MISTS AND FUMES CANNOT BE ELIMINATED, THE OPERATOR AND ANY BYSTANDERS SHOULD ALWAYS WEAR A RESPIRATOR APPROVED BY OSHA/MSHA FOR THE MATERIAL BEING CUT.

Safety

HYDRAULIC SAFETY

Maintaining a Safe Work Environment

Establishing a safe work environment in and around your hydraulic equipment is extremely important. The easiest and most effective way to avoid problems is to make sure associates understand their equipment, know how to operate the machines safely, and recognize the dangers if handled carelessly. A few things to be aware of are:

- **Pressure:** Hydraulic fluid under pressure is dangerous and can cause serious injury. Never look for a leak when unit is under pressure. Using your hand could cause serious injury. A few common ways to encounter hydraulic fluid under pressure include:
 - Pinhole: Fluid under pressure can cause serious injury. It can be almost invisible escaping from a pinhole, and it can pierce the skin into the body.



DANGER: DO NOT TOUCH A PRESSURIZED HYDRAULIC HOSE ASSEMBLY WITH ANY PART OF THE BODY. IF FLUID PUNCTURES THE SKIN, EVEN IF NO PAIN IS FELT, A SERIOUS EMERGENCY EXISTS. OBTAIN MEDICAL ASSISTANCE IMMEDIATELY. FAILURE TO DO SO COULD RESULT IN LOSS OF THE INJURED BODY PART OR DEATH.

- Leak: Keep fittings and hoses tight. Only check and service when not under pressure. Leaking hydraulic fluid is hazardous; in addition to making workplace floors slippery and dangerous, it also contaminates the environment. Before cleaning an oil spill, always check EPA, state, and local regulations.
 - Burst: Whether due to improper selection or damage, a ruptured hose can cause injury. If it bursts, a worker can be burned, cut, injected, or may slip and fall.
 - Coupling Blow-Off: If the assembly is not properly made or installed, the coupling could come off and hit or spray a worker, possibly resulting in serious injury. Never operate machine without guards.
- **Flammability:** When ignited, some hydraulic fluids can cause fires and/or explode. With the exception of those comprised primarily of water, all hydraulic fluid is flammable (including many “fire-resistant” hydraulic fluids) when exposed to the proper conditions. Leaking pressurized hydraulic fluids may develop a mist or fine spray that can flash or explode upon contact with a source of ignition. These explosions can be very severe and could result in serious injury or death. Precautions should be taken to eliminate all ignition sources from contact with escaping fluids, sprays or mists resulting from hydraulic failures. Sources of ignition could be electrical discharges (sparks), open flames, extremely high temperatures, sparks caused by metal-to-metal contact, etc.



CAUTION: NEVER USE YOUR HANDS TO CHECK FOR LEAKS OVER HOSE OR HYDRAULIC CONNECTIONS. USE A PIECE OF CARDBOARD TO LOCATE A PRESSURIZED LEAK. FOR LOW PRESSURE LEAKS (DRIPS), USE A RAG TO CLEAN THE AREA AND DETERMINE WHERE THE LEAK ORIGINATES.

- **Mechanical:** Hydraulic fluid creates movement, which means some equipment may move. Observe surroundings and equipment at all times.
- **Moisture:** Do not use in wet or high moisture conditions.
- **Electrical:** Faulty wiring can be an electrical hazard. A regular preventive maintenance program should always include a wiring check. If applicable, disconnect battery before servicing.
- **Temperature:** Because this machine operates at a relatively low pressure, overheating is not common. If surface of tank becomes too hot to touch by hand (above 130°F or 55°C), shut off machine and allow it to cool.

Hydraulic Fluid

Only use Texaco Rando 46 Hydraulic Oil or compatible fluid like ISO or AW #46 from a brand name manufacturer. Non-compatible fluids could cause damage to unit or serious injury.

ELECTRICAL PRACTICES



WARNING: ELECTRICAL CORDS CAN BE HAZARDOUS. MISUSE CAN RESULT IN FIRE OR DEATH BY ELECTRICAL SHOCK. READ CAREFULLY AND FOLLOW ALL DIRECTIONS.



CAUTION: ALWAYS FOLLOW APPLICABLE ELECTRICAL CODES, STANDARDS AND/OR REGULATIONS. CONSULT YOUR LOCAL ELECTRICAL AUTHORITY OR A LICENSED ELECTRICIAN BEFORE ATTEMPTING TO MODIFY AN ELECTRICAL INSTALLATION. ENSURE THAT CIRCUIT AND GROUND FAULT PROTECTION DEVICES AND ALL OTHER ELECTRICAL SAFETY EQUIPMENT ARE FUNCTIONING PROPERLY.

Extension Cord Requirements



WARNING: GROUND YOUR EQUIPMENT. THE EQUIPMENT MUST BE PLUGGED INTO AN APPROPRIATE OUTLET, ONE WHICH IS PROPERLY INSTALLED AND GROUNDED IN ACCORDANCE WITH ALL CODES AND ORDINANCES. DO NOT MODIFY THE PLUG PROVIDED WITH THE EQUIPMENT. NEVER REMOVE THE GROUNDING PRONG FROM THE PLUG.



WARNING: DO NOT REMOVE, BEND OR MODIFY ANY METAL PRONGS OR PINS OF THE PLUG. MODIFICATIONS TO POWER CORDS AND/OR PLUGS MAY RESULT IN INJURY AND/OR EQUIPMENT DAMAGE.

- Ensure the cord type is suitable for the application and location. If you are unsure about your cord type, consult a qualified electrical professional or electrician.
- FULLY INSERT plug into outlet.
- Do not use excessive force to make connections.
- Never unplug by pulling the cord from the outlet. Pull plug rather than cord to reduce the risk of damage.
- Regularly examine your extension cord and ensure it is in good electrical condition. Never use a damaged cord—either replace it or have it repaired by a qualified person.
- Protect your extension cords from sharp objects, excessive heat and damp or wet areas. Keep the cord away from oil, cutting edges and moving parts.
- Do not drive, drag or place objects over cord.
- Avoid overheating. Uncoil cord and do not cover it with any material.
- Avoid accidental starting. Be sure equipment is turned off before plugging in. Do not use equipment if the power switch does not turn the equipment on and off.
- Make sure equipment is not running before disconnecting cord.
- Unplug equipment. When not in use and before changing accessories or performing maintenance, unplug the machine.

Extension Cord Selection

All cords should be sized appropriately to reduce the risk of damage, fire or reduced performance. Reference the table in this section for cord sizes.

Safety

ELECTRICAL PRACTICES (CONT'D)

How to Use This Table

1. Determine your supply voltage.
2. Determine the total length of your cord including all extension cords.
3. Determine the maximum amp draw for your machine.
4. Trace your voltage across the top of the table to the first length that is greater than or equal to your cord length.
5. Follow the column down to the first row that contains a maximum amp draw greater than or equal to yours.
6. This cell contains the minimum wire size for your application.

Example

Application: Max Amps = 11A, Length = 40ft, Voltage = 120V 1ph

Solution: 40ft is between the 25ft and 50ft columns, so the larger of the two columns is chosen. Likewise, 11A is between the 10A and 12A rows, so the larger of the two rows is chosen. 14 AWG (2.5mm²) is the minimum wire size for this example.

Single Phase Equipment				
Max Length	120V Supply	25ft (7.5m)	50ft (15m)	75ft (22.5m)
	230V Supply	50ft (15m)	100ft (30m)	150ft (45m)
Max Amps		Minimum Wire Size		
8	16 AWG (1.5mm ²)	16 AWG (1.5mm ²)	16 AWG (1.5mm ²)	16 AWG (1.5mm ²)
10	16 AWG (1.5mm ²)	16 AWG (1.5mm ²)	16 AWG (1.5mm ²)	16 AWG (1.5mm ²)
12	14 AWG (2.5mm ²)	14 AWG (2.5mm ²)	14 AWG (2.5mm ²)	14 AWG (2.5mm ²)
14	14 AWG (2.5mm ²)	14 AWG (2.5mm ²)	14 AWG (2.5mm ²)	14 AWG (2.5mm ²)

Extension Cord Sizes

Single Phase Equipment							
Max Length	120V Supply	25ft (7.5m)	50ft (15m)	75ft (25m)	100ft (30m)	150ft (45m)	200ft (60m)
	230V Supply	50ft (15m)	100ft (30m)	150ft (45m)	200ft (60m)	300ft (90m)	400ft (120m)
Max Amps		Minimum Wire Size					
8	16 AWG (1.5mm ²)	16 AWG (1.5mm ²)	16 AWG (1.5mm ²)	16 AWG (1.5mm ²)	16 AWG (1.5mm ²)	14 AWG (2.5mm ²)	14 AWG (2.5mm ²)
10	16 AWG (1.5mm ²)	16 AWG (1.5mm ²)	16 AWG (1.5mm ²)	16 AWG (1.5mm ²)	16 AWG (1.5mm ²)	14 AWG (2.5mm ²)	12 AWG (4mm ²)
12	14 AWG (2.5mm ²)	14 AWG (2.5mm ²)	14 AWG (2.5mm ²)	14 AWG (2.5mm ²)	14 AWG (2.5mm ²)	12 AWG (4mm ²)	12 AWG (4mm ²)
14	14 AWG (2.5mm ²)	14 AWG (2.5mm ²)	14 AWG (2.5mm ²)	14 AWG (2.5mm ²)	14 AWG (2.5mm ²)	12 AWG (4mm ²)	10 AWG (6mm ²)
16	14 AWG (2.5mm ²)	14 AWG (2.5mm ²)	14 AWG (2.5mm ²)	14 AWG (2.5mm ²)	14 AWG (2.5mm ²)	12 AWG (4mm ²)	10 AWG (6mm ²)
18	14 AWG (2.5mm ²)	14 AWG (2.5mm ²)	14 AWG (2.5mm ²)	12 AWG (4mm ²)	12 AWG (4mm ²)	12 AWG (4mm ²)	10 AWG (6mm ²)
20	12 AWG (4mm ²)	12 AWG (4mm ²)	12 AWG (4mm ²)	12 AWG (4mm ²)	12 AWG (4mm ²)	10 AWG (6mm ²)	10 AWG (6mm ²)
25	12 AWG (4mm ²)	12 AWG (4mm ²)	12 AWG (4mm ²)	12 AWG (4mm ²)	12 AWG (4mm ²)	10 AWG (6mm ²)	8 AWG (10mm ²)
30	10 AWG (6mm ²)	10 AWG (6mm ²)	10 AWG (6mm ²)	10 AWG (6mm ²)	10 AWG (6mm ²)	8 AWG (10mm ²)	8 AWG (10mm ²)

Note: The table is based on a <10% voltage loss, data from the U.S. National Electrical Code Tables 400.5(A) & 400.5(B) and typical resistances for copper wire.

Components and Assembly

WHEEL MODES

Wheels engage and disengage for better maneuverability. Wheels in the “engage mode” are secured with axle pins (Figure 1), which engage the wheels so the machine can be self-propelled.

When wheels are in the “disengage mode” (Figure 1.1), the machine can be moved freely when not under power.

Disengaging Wheels

1. Lift ring outwards; slide pin out and off.
2. Repeat on second wheel.

Note: Keeping the axle pin facing straight up will make re-engaging easier.

Re-engaging Wheels

1. Line up wheel hub hole and axle hole (Figure 2).
2. Insert pin and push ring over the hole so that it is parallel to the wheel.
3. Repeat on second wheel.

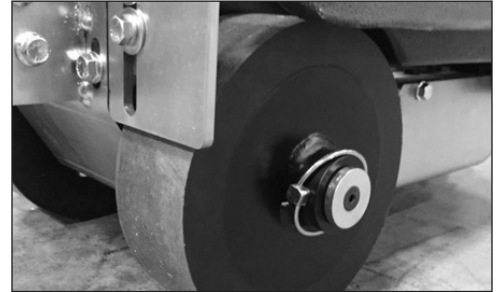

FIG. 1

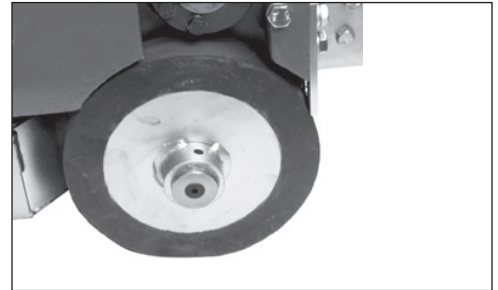

FIG. 1.1

TRANSPORT

Lifting Bail

The lifting bails make loading/unloading easier when unable to use a ramp. Location of lifting bails centers the balance of the machine, making it safe to pick up machine.

1. Place rope, hook system, or chain through eyelets located on top of machine.
2. Raise machine with a fork lift or winch; slowly lower to desired location.

Ramp Loading

1. Engage the wheels.
2. Make sure ramp is clean and dry, free of grease or oil.
3. Position ramp securely to back of vehicle; ensure there is good contact (Figure 3).
4. Position machine at bottom of ramp (Figure 3.1).
5. Engage power switch and drive onto vehicle.

Ramp Unloading

1. Engage the wheels.
2. Position ramp securely to back of vehicle; ensure there is good contact (Figure 3).
3. Position machine in line with the ramp at the back of the truck (Figure 3.1).
4. Carefully move machine onto ramp, leaving the cutting head in contact with the ramp surface. **Note:** Machine is heavy, be cautious while moving.
5. Slowly back machine down ramp.

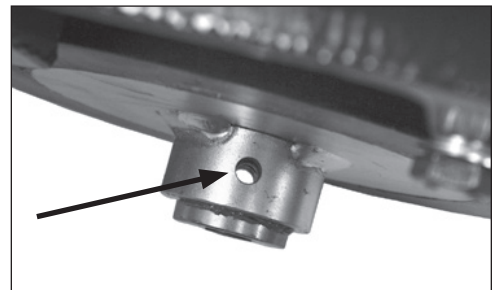

FIG. 2

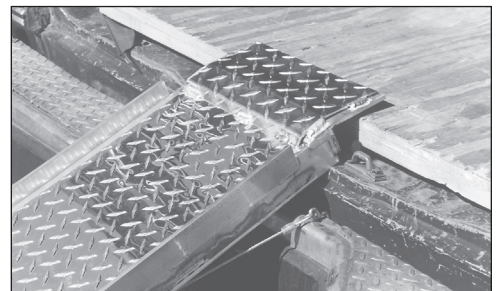

FIG. 3

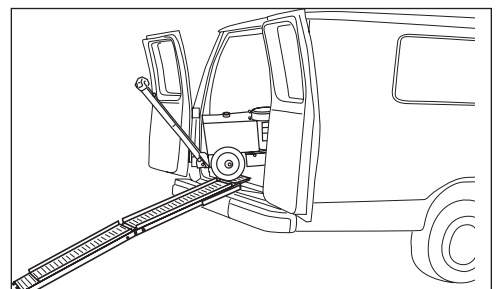
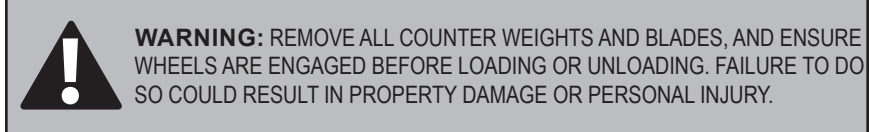

FIG. 3.1



Components and Assembly

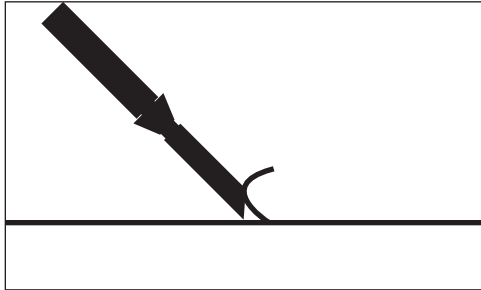

FIG. 4

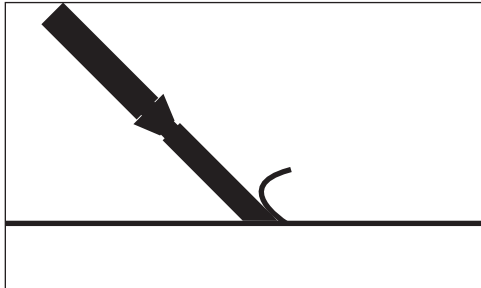

FIG. 4.1

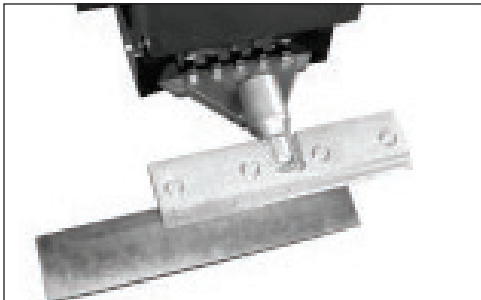

FIG. 4.2

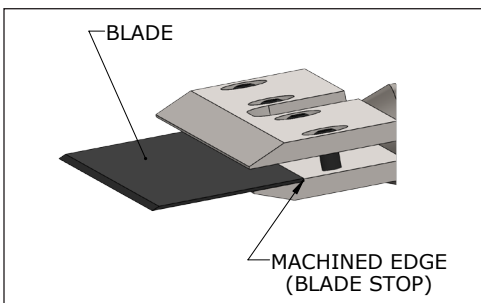

FIG. 5

BLADES



CAUTION: BLADES ARE SHARP, USE EXTREME CAUTION WHEN HANDLING. NEVER CHANGE CUTTING HEAD OR SERVICE BLADES WHILE MACHINE IS RUNNING. ALWAYS WEAR GLOVES AND EYE PROTECTION WHEN HANDLING BLADES.

Blade Setting

Note: This machine is designed for soft goods and most hard good removal applications.

- Depending on the material and sub-floor type, proper blade size and placement will affect performance.
- For harder jobs, use a smaller blade.
- Start with a narrow blade, then increase blade size to optimize cutting pass. Narrower blades work easier than wider blades, and usually clean the floor better. Wider is not always better or faster.
- Normally, bevel on the blade is up for concrete (Figure 4); bevel down for wood (Figure 4.1).
- Dull blades greatly affect the performance of the machine and reduce cutting ability. Sharpen or replace as needed.
- Keep work area clean and clear of debris. After removing a portion of material, move it out of the way.
- Pound down or remove any nails or metal obstruction on wood or wood-like floors to avoid blade damage.
- Blades can be offset in the cutting head (Figure 4.2) for easier access to toe kicks or for removal along the wall.
- Sheet vinyl, solid vinyl, rubber tile, urethane, or PVC sheet roofing will need to be scored for best results. NFE recommends using a self-scoring blade.
- Self-scoring blades eliminate the need for pre-scoring material. Depending upon the type of material being removed and the sharpness of the blade and scoring wings, the self-scoring blades may make it harder to control the machine. Keep scoring wings sharp at all times.

Blade Changing

1. Place a flat piece of wood under the front of the machine.
2. Use supplied extended "T" wrench or a 7/32 Allen wrench with at least a 3" extension to keep hand safely away from the sharp edge of the blade. Loosen four Allen head bolts. It is not necessary to remove bolts.
3. Place blade into the cutting head and slide back until fully seated against the machined edge (Figure 5).

Note: Do not insert blade all the way back to the bolts. Incorrect installation of blade will cause insufficient clamping leading to premature blade wear and damage.

If the blade is wider than the cutting head, center the blade to the head. If the blade is smaller than the cutting head, the blade should be mounted in the center of the cutting head during the first pass. After the first pass is made, the blade can be offset in the head to allow the wheels to keep even contact with the floor and provide easy access to the wall.

4. Tighten the bolts.

Components and Assembly

Blade Sharpening

During use, blades develop a back-bevel (Figure 6). Blade will not be completely sharpened until all back-bevel is gone.

Note: *Thinner blades are easier to sharpen, but they also break easier.*

- Grind blade using a 4" diameter disk with 120 or finer grit. Be careful not to catch disk on edge or corner of blade.
- Pass grinder along blade edge, starting on one end and continuing in one direction. Grind until sharp.
- Using a good quality fine tooth hand file, use same procedure as above.
- Have plenty of sharp blades on each job so that on-the-job blade sharpening is eliminated.
- It is best to sharpen dull blades on proper bench or belt grinder.

Self-Scoring Blade Sharpening

It is important to keep the "wings" on a self-scoring blade sharp (Figure 7). Use a file on the wing edge. Sharpen the flat part of the blade the same way as described above.

ANGLE ATTACHMENTS

These attachments angle the cutting head and blade or carbide shank to where the material comes up the easiest. Lower is usually the best.

Mounting Angle Attachment

1. Mount angle attachment onto the cutting head support (Figure 8).
2. Securely tighten all five mounting bolts.

Mounting Blade Holder/Shank

1. Disconnect machine from power source.
2. Block up machine.
3. Insert desired cutting head or carbide shank into the angle attachment.

Note: *Cutting head or carbide shank should swivel freely in the angle attachment. This movement allows the blade to stay in contact with the floor. Grease may need to be applied to the shaft of the attachment before inserting.*

4. Secure with retainer cap (Figure 8.1).

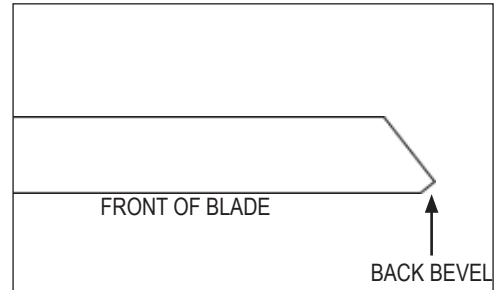

FIG. 6

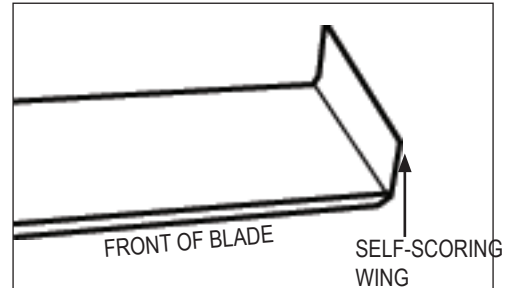

FIG. 7

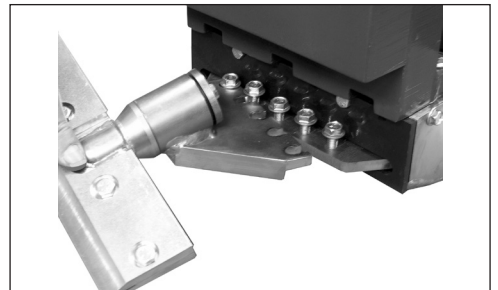

FIG. 8

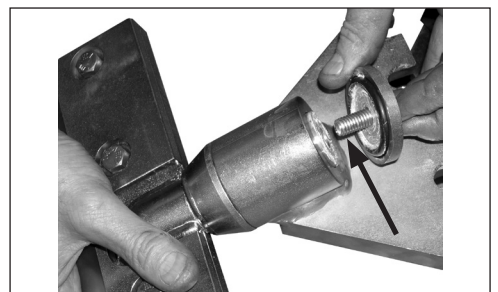

FIG. 8.1

Operation

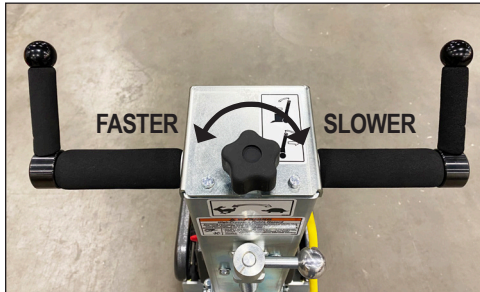

FIG. 9

OPERATING CONTROLS

Speed Control (Figure 9)

- Turn speed control knob clockwise to decrease maximum forward speed.
- Turn speed control knob counterclockwise to increase maximum forward speed.
- Speed control knob can be adjusted while machine is running.

Forward/Reverse

- Push handles forward to move the machine forward.
- Pull handles backward to move the machine in reverse.

START-UP PROCEDURE

Starting the Machine

1. The ON/OFF switch must be in the “OFF” position before connecting to a power source (domestic machines only).
2. Plug machine into power source.
3. Turn speed control knob to slowest position (Figure 9).
4. Press ON/OFF switch to the “ON” position.
5. Push or pull the handles to move the machine forward or backwards.

Turning Off the Machine

Press ON/OFF switch to the “OFF” position to turn off machine.

INSTALLING AND ADJUSTING SLIDE WEIGHTS



WARNING: ALWAYS ENSURE THE HEX BOLTS ARE TIGHT AND THE SLIDE WEIGHTS ARE SECURE. UNSECURED WEIGHTS COULD SHIFT CAUSING BODILY INJURY. USE CAUTION IF LOOSENING THE HEX BOLTS—IF BACKED OUT TOO FAR, THE SLIDE WEIGHTS COULD DROP CAUSING BODILY INJURY.

Installing Slide Weights

Orientate the slide weight with the long channel below the short channel. Install the long channel over the heads of the two Allen bolts. Holding the slide weight in place, install the hex bolt into the threaded hole aligned with the short channel. Tighten the hex bolt using a 3/4” socket wrench to secure the weight to the side of the machine.

Adjusting Slide Weights

To adjust the slide weight forward or backward based on the job application, loosen the hex bolt using a 3/4” socket wrench and gently slide the weight to the desired position. After adjusting, retighten the hex bolt to secure the weight to the side of the machine.

TYPES OF APPLICATIONS

VCT Tile: Never use a blade wider than the size of the tile being removed. If material still does not come up clean or machine jumps on top of material, reduce blade size or use a smaller portion of the blade.

Pure Vinyl Rubber Tile: Material will need to be scored down to 10-12" (25.4-30.5 cm) for proper removal. Self-scoring blades can be used with some materials. A 10" (25.4 cm) blade is recommended for this application.

Ceramic: Carbide shanks are most effective for removing ceramic. On small block-styles of tile, pre-breaking may not be necessary. Open an area large enough for machine or blade to fit in, or start from a doorway. Use slow speed.

Direct-Glued Carpet: NFE recommends using a self-scoring blade. Normally 6-14" (15.2-35.6 cm) self-scoring blades are used on direct-glued carpet, secondary-backed, unitary, double-glued, vinyl foam and urethane foam.

Wood: Wood Floor Shank (#7082-8) was specifically designed to use on the 6280HD Gladiator and will usually work best. In most instances it is necessary to pre-score the wood floor every 6-8" (15.2-20.3 cm), 90% through the floor, in a cross-grain fashion. Use the 9-degree angle attachment (#402276) to keep the shank low to the floor. Using the machine on a slow speed will help.

Thin Coatings: Use razor blades with a razor blade cutting head or a carbide shank. Experiment to see which method works the best for the job application.

Re-scrape: Use razor blades with a razor blade cutting head or a .062 standard blade. Experiment to see which method works the best for the job application. Use a sharper angle of attack if necessary.

Subfloor Surfaces

Glued Hardwood Flooring: A 10" (25.4 cm) blade is recommended for regular adhesive; a 6" (15.25 cm) blade for epoxy. For proper removal of hardwood flooring (plank solid, plank laminated, parkay laminated), flooring must be scored to blade width. This is done by using a circular saw set at a depth of 99% of the thickness of the board, just missing the subfloor surface when on concrete (Figure 10). A chalk line for scoring lines can be used across the floor the width of the blade (Figure 11). A ripping guide attached to the saw can be used to eliminate chalk line marks. For true parkay flooring, scoring is not necessary. It will come up in small pieces. Open an area large enough to fit machine or start from a doorway.

Wood: When working over plywood sub-flooring, run machine in the same direction as the grain in the wood. Blade works best bevel down. On solid wood floors (e.g. plank), run in the same direction as the plank, not perpendicular to grain or plank. Removing the front counter weight(s) will help on all soft surfaces.

Concrete: For best performance, position blade bevel up when working on a concrete slab or cleaning adhesive. On occasion, bevel down gives better blade life. Test each job for best performance.

Gypcrete and Soft-Poured Flooring: Position blade bevel down to create a better wearing surface, although bevel up may work if front counter weight is removed.

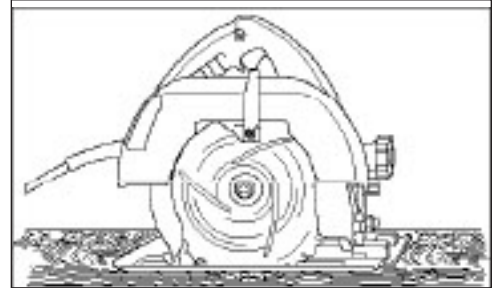

FIG. 10

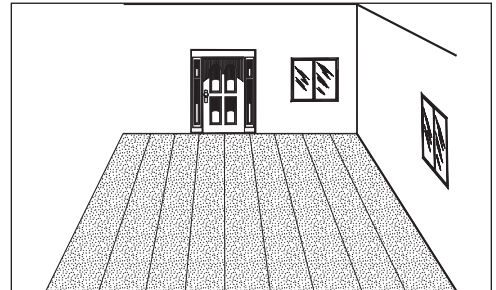

FIG. 11

Troubleshooting Guide

Problem	Cause	Solution
Machine will not start.	Insufficient power.	Ensure use of properly rated extension cord.
	Loose capacitor leads.	Check capacitor leads to ensure good connection.
	Overload button on motor has been tripped.	Button is located on the bottom of the electric box on motor. If tripped, hold button in until it clicks.
	Faulty ON/OFF switch.	Replace if needed.
Machine will not move under power.	Speed control is set too slow.	Turn speed control knob counterclockwise until the machine goes forward.
	Wheels are not in the "engage mode".	Install wheel pins for "engage mode".
	Broken belt.	Remove wheels and bottom cover to inspect. Replace if needed.
	Broken chain.	Remove wheels and bottom cover to inspect; repair or replace if needed.
	Control handle mechanism failure.	Inspect control mechanism; repair or replace as needed.
Motor is humming, but machine does not run or breakers are blown.	Failed isolators.	Remove wheels and bottom cover to inspect.
	Failed capacitors.	Replace as needed.
	Motor start switch connections are dirty.	Remove fan cover and fan. Clean the motor start switch (set of points) with an emery board or cloth between the points; reassemble.
Machine is leaking hydraulic fluid.	Leak in hose(s).	Tighten; replace if needed.
	Hydraulic fittings are loose.	Tighten; replace if needed.
Motor is heating up.	Motor shaft is binding.	Remove wheels and cover to inspect isolators. Inspect cutting head bearing and eccentric to ensure that they are not binding. If issue continues, contact NFE for additional support.
Machine won't propel forward, only in reverse.	Speed control is set too slow.	Turn speed control knob to the left (counterclockwise).
Shank doesn't fit into angle attachment.	Burrs inside angle attachment.	Use round file until burrs are gone.
	Damage to shank insert end.	Remove damage with file or hand grinder. Replace shank if necessary.



WARNING: ALWAYS UNPLUG MACHINE BEFORE PERFORMING MAINTENANCE.

WHEEL CLEANER ADJUSTMENT

1. Loosen wheel cleaner with 9/16" wrench (Figure 12).
2. Slide cleaner up to the face of the wheel until it touches, but does not dig into the wheel surface.
3. Re-tighten firmly. **Note:** Too much interference between the wheel and cleaner will damage wheel.

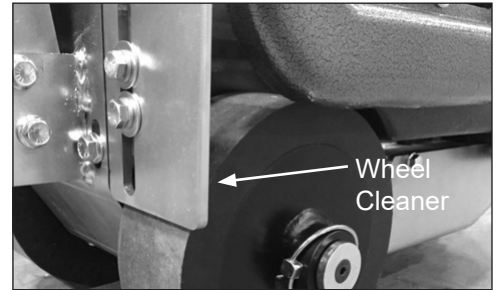

FIG. 12

WHEEL REMOVAL

1. Turn off and unplug machine.
2. Examine back of wheels for built-up debris.
3. Remove yarn build-up.
4. Place block under machine between wheels.
5. Disengage and remove axle pin (Figure 13).
6. Remove wheel-securing screw with a 5/16" hex wrench (Figure 13).
7. Remove wheel-securing cap. Wheel will slide off.
8. Remove wheel spacer. This should be inspected at regular intervals.
9. Relubricate bearing inside wheel before reassembly.

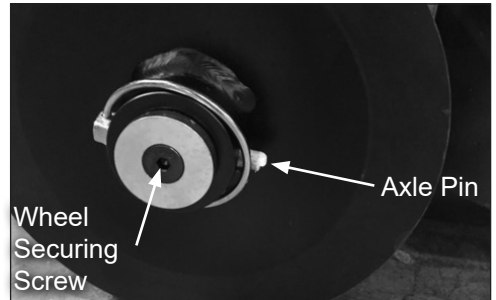

FIG. 13

ADDING OR CHANGING HYDRAULIC FLUID

- Change or add fluid when needed; check fluid level if there has been a leak, damaged or ruptured hose, or a loose fitting. Fluid should be level with bottom of tank plug hole (Figure 14).
- **To add fluid**, unscrew filler port cap from top of machine (Figure 15.1); add fluid through a filter or funnel with a screen to keep fluid clean.
- **To change fluid**, remove filler port cap. Remove drain plug from side of machine (Figure 15.2). A 2 gallon (8 liter) container will be needed to drain the fluid into. (Fluid will not be removed from hoses.) Regardless of the machine's straining system, add fluid through a filter or funnel with a screen to keep fluid clean.

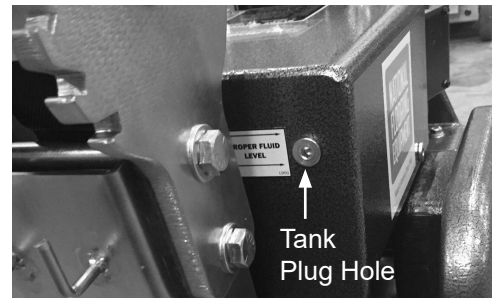

FIG. 14



FIG. 15.1

INSPECTION OF INTERNAL PARTS

Visual inspection of internal parts can be done without draining the tank.

1. Remove two lifting bail eyebolts and the two bolts from the back of the tank.
2. Carefully lift tank 3-4" (8-10 cm).
3. Using a flashlight, inspect the drive chain, hoses, front seal on hydraulic motor, and suction and pressure line on pump.
4. If service is necessary, follow the procedure for tank removal.



FIG. 15.2

Maintenance

TANK REMOVAL

It is necessary to remove the tank in order to repair the pump, or to replace or service internal hoses.

1. Drain tank by removing the top filler port cap and drain plug on the side of the machine (Figure 12). A two gallon container will be needed to drain the fluid into.
2. Replace drain plug and filler port cap.
3. Remove two lifting bail eyebolts and the two bolts from the back of the tank.
4. Disconnect return line on the back of the tank; carefully lift tank 3-4" (8-10 cm) and disconnect suction line. The tank can now be removed.

POWER CORD

If the power cord is damaged, it must be replaced by NFE or a qualified professional.

ISOLATORS

Inspection

1. Perform the wheel removal procedure to access the bottom cover.
2. Remove one wheel at a time; remove the bottom cover bolt behind each wheel.
3. Carefully remove the bottom cover to expose the underside.
4. Inspect the isolators from the side for damage or wear.

Replacement

1. Remove the side slide weights, side weights, and front weight.
2. Loosen the nine socket head cap screws holding the isolators in place. Grip each isolator with locking pliers to aid in loosening.
3. Remove and replace each isolator. It is recommended adding red threadlocker to the threads of the cap screws when reinstalling.

CUTTING HEAD BEARING

Inspection

1. Perform the wheel removal procedure to access the bottom cover.
2. Remove one wheel at a time; remove the bottom cover bolt behind each wheel.
3. Carefully remove the bottom cover to expose the underside.
4. Inspect the cutting head bearing for damage or wear.

Replacement

1. Remove the bottom cover.
2. Remove the cutting head bearing from the cutting head by removing the four bolts that hold down the bearing.
3. Replace the cutting head bearing and re-tighten the four bolts.
4. Place the bottom cover and re-tighten the eight bolts that hold the bottom cover in place.

Maintenance

Maintenance to be performed	Interval			
	Daily	50 hrs	1000 hrs	2000 hrs
Inspect fasteners, wheels and blade holders for damage.	•			
Clean built-up glue and debris from wheels, front weight, and blade holder.	•			
Visually inspect internal parts.		•		
Inspect safety devices and switches (power cord, wheel cleaners, switches).		•		
Inspect and replace isolators.			•	
Inspect and replace cutting head bearing.			•	
Change hydraulic fluid.				•

Parts List and Diagrams

OVERALL MACHINE (DOMESTIC SHOWN)

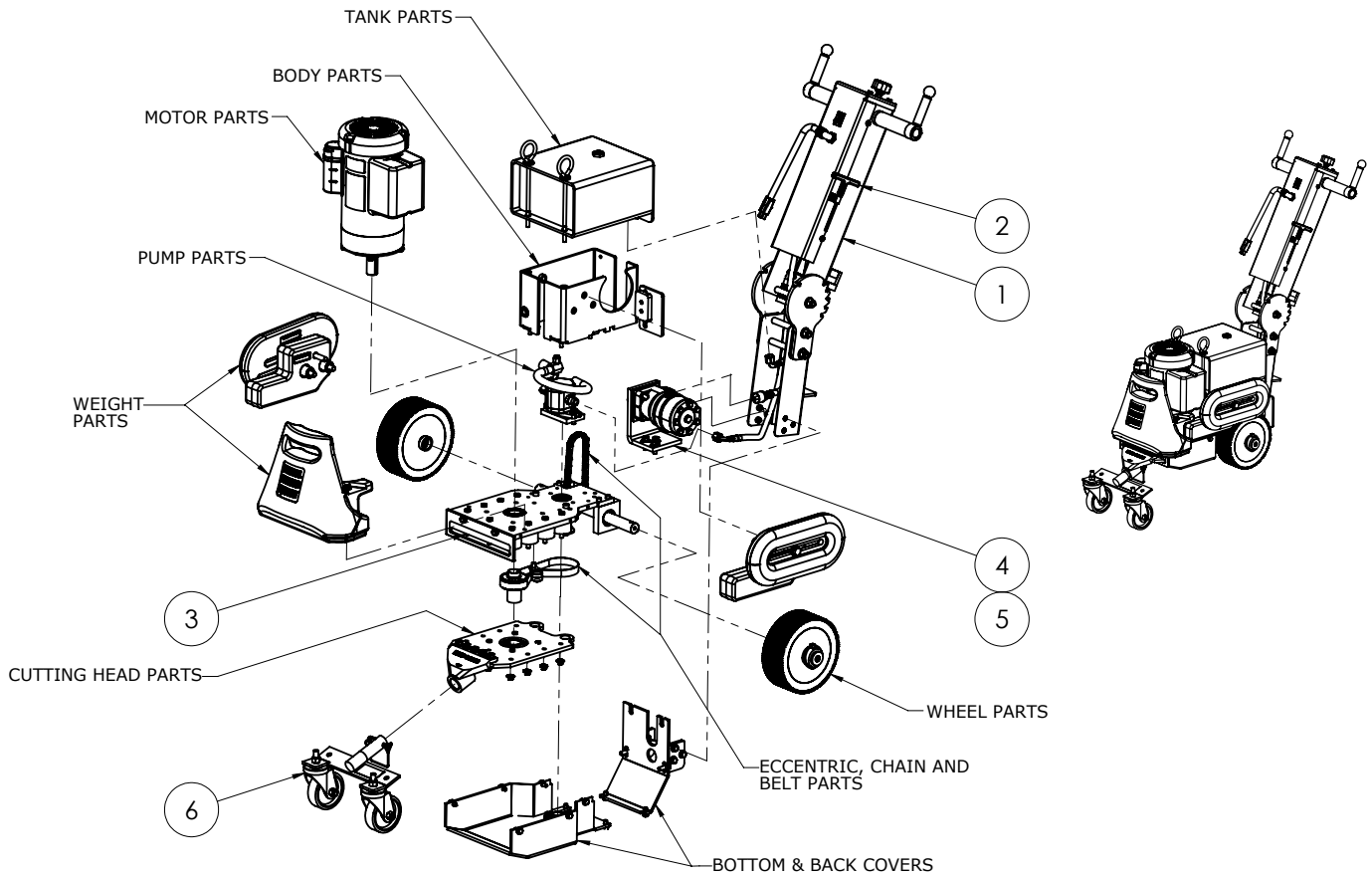

ITEM NO.	6280HD-10XXXX 6280HD-12XXXX 6280HD-23XXXX	6280HD-11XXXX	6280HD-13XXXX	6280HD-20XXXX	DESCRIPTION	QTY.
1	401577				Assembly, Commander Handle, 115V	1
		404581-011			Assembly, Commander Handle, EUR	1
			404581-013		Assembly, Commander Handle, AUS	1
				404581-020	Assembly, Commander Handle, UK	1
2	6280-401B				Wrench, Allen, 7/32	1
3	6280HD-BASEASSY				Base Assembled, 6280HD	1
4	6280HD-HYDMOTOR				Motor, Hydraulic, Sub, 6280HD	1
5	73222				Screw, Hex Head Cap, Flange, 3/8-16 x 1	3
6	6280HD-250				Assembly, Transport Wheel, 6280HD	1

Parts List and Diagrams

BASE ASSEMBLY 6280HD-BASEASSY

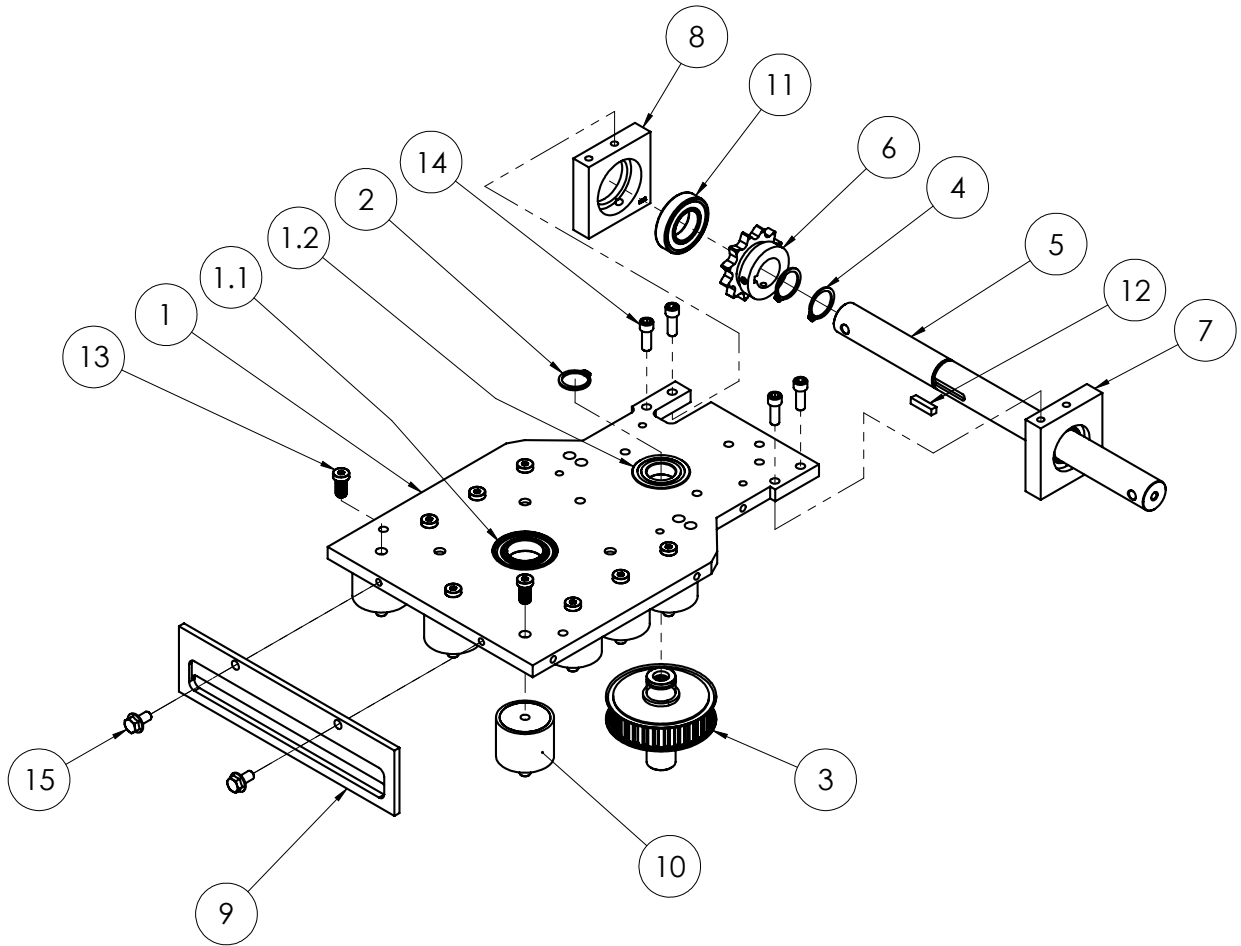

ITEM NO.	PART NO.	DESCRIPTION	QTY.
1	404591	Assy, Plate, Base, With Bearings, 6280HD	1
1.1	71132	Bearing, Ball, 1.25 x 2.25 x .5	1
1.2	71115	Bearing, Ball, 1 x 2 x .5	1
2	6280-103A	Ring, Retaining, External, Axial, 1", Heavy, Phosphate	1
3	402210	Pump Drive Assy, Splined, HD	1
4	6280HD-102	Ring, Retaining, External, Axial, 1-1/8", Phosphate	4
5	6280HD-103	Axle, Drive	1
6	6280HD-104	Sprocket, Axle	1
7	6280HD-105L	Support, Axle Bearing, Left	1
8	6280HD-105R	Support, Axle Bearing, Right	1
9	6280HD-145	Cover, Front	1
10	405950	Isolator, Vibration, 2 x 1-5/8, M/F, Neoprene	9
11	71128	Bearing, 1-1/8ID R18-2RS	2
12	73033	Key, 1/4 x 1/4 x 1"	1
13	73217	Screw, Socket Head Cap, Low, 3/8-16 x 3/4	9
14	73310	Screw, Socket Head Cap, Grade 5 5/16-18x7/8	4
15	73318	Bolt, Wizlock Flange 5/16-18x5/8	2

Parts List and Diagrams

BODY

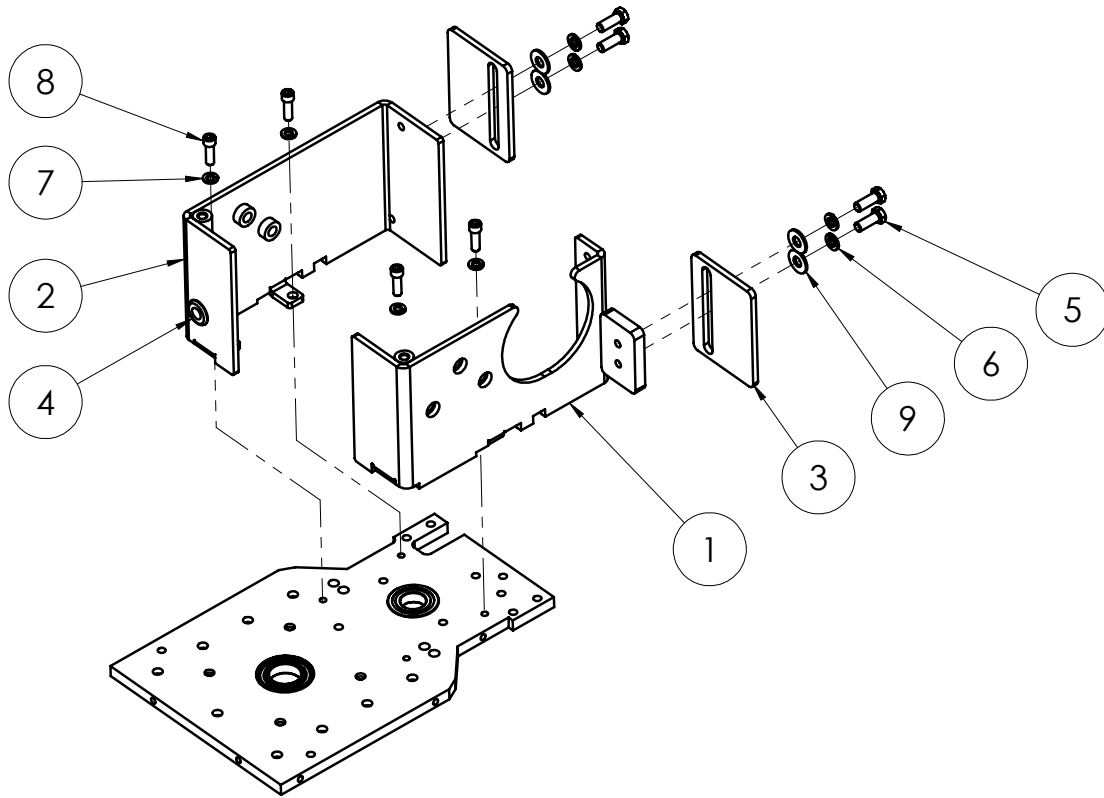

ITEM NO.	PART NO.	DESCRIPTION	QTY.
1	6280-156L	Body, Main, Upper, Left	1
2	6280-156R	Body, Main, Upper, Right	1
3	6280HD-165	Cleaner, Wheel	2
4	74763	Grommet, Rubber 1/2"	1
5	73201	Screw, Hex Head Cap, 3/8-16 x 1	8
6	73204	Washer, Lock, 3/8	8
7	73303	Washer, Split Lock 5/16	4
8	73311	Screw, Socket Head Cap, 5/16-18 x 1	4
9	73264	Washer, Flat, Zinc USS 3/8	4

Parts List and Diagrams

WEIGHTS

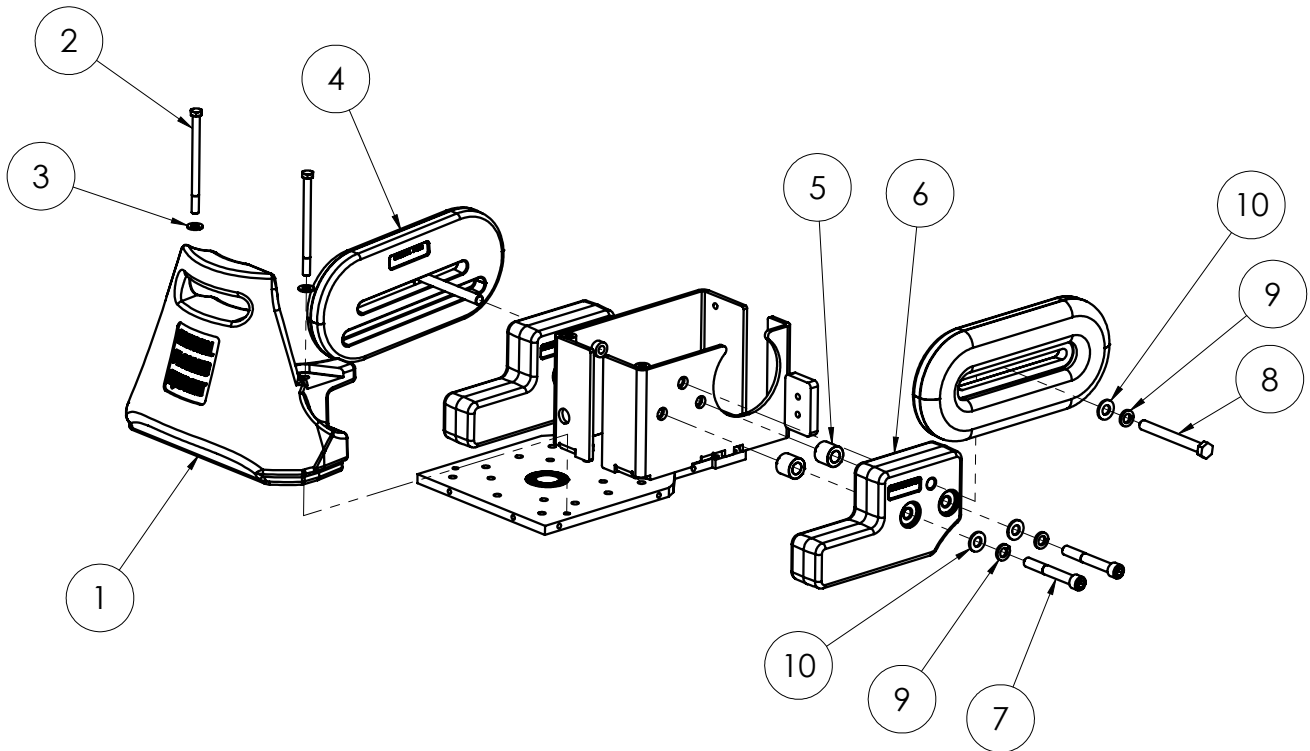

ITEM NO.	6280HD-10XXXX 6280HD-11XXXX 6280HD-13XXXX 6280HD-20XXXX 6280HD-23XXXX	6280HD-12XXXX	DESCRIPTION	QTY.
1	401564-SV		Weight, Counter, Front, Silver Vein	1
		401564-G	Counterweight, Front, Cast, Green	1
2	402225	402225	Bolt, Hex Head Cap 3/8-16 X 5-1/2	2
3	73263	73263	Washer, Flat SAE Zinc 3/8	2
4	74851-SV		Weight, Slide, Silver Vein	2
		74851-G	Weight, Slide, Green	1
5	6280HD-109	6280HD-109	Spacer, Weight	4
6	74853-BLK	74853-BLK	Side Weight, Black	2
7	400159	400159	Bolt, Socket Head Cap Screw, 1/2-13 x 3-3/4	4
8	73426	73426	Screw, Hex Head Cap, 1/2-13x4-3/4	2
9	73403	73403	Washer, Split lock 1/2	6
10	73424	73424	Washer, Flat, Zinc SAE 1/2	6

Parts List and Diagrams

TANK

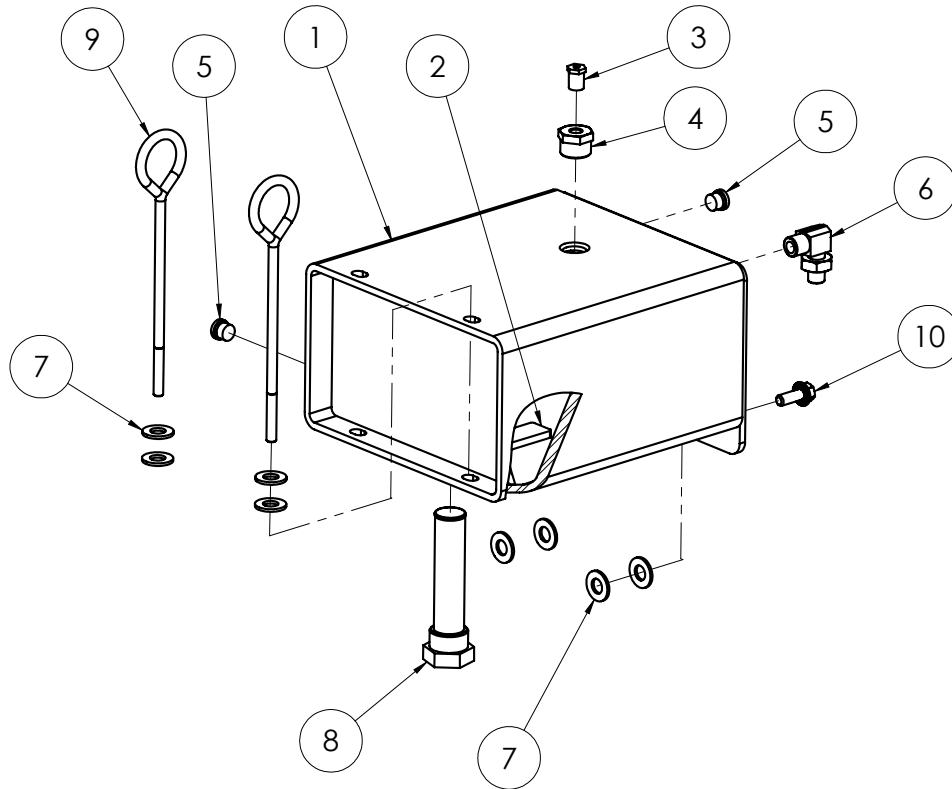

ITEM NO.	6280HD-10XXXX 6280HD-11XXXX 6280HD-13XXXX 6280HD-20XXXX 6280HD-23XXXX	6280HD-12XXXX	DESCRIPTION	QTY.
1	6280-162-SV		Tank, Hydraulic, Weldment, Silver Vein	1
		6280-162-G	Tank, Hydraulic, Green	1
2	6280-162G	6280-162G	Magnet, Tank	1
3	6280-161B	6280-161B	Plug, Vent, Filler Cap	1
4	6280-161D	6280-161D	Plug, Filler Port	1
5	6280-214	6280-214	Plug, Tank	2
6	72816	72816	Adapter, Hydraulic, 90 deg, -6M ORFS, -6M ORB	1
7	401452	401452	Washer, Flat, 1/2", SAE	8
8	70601	70601	Strainer, Tank Mounted	1
9	403882	403882	Eye Bolt, 1.50 ID, 3/8-16 x 8	2
10	73222	73222	Bolt, Flange 3/8-16 x 1	2

Parts List and Diagrams

CUTTING HEAD

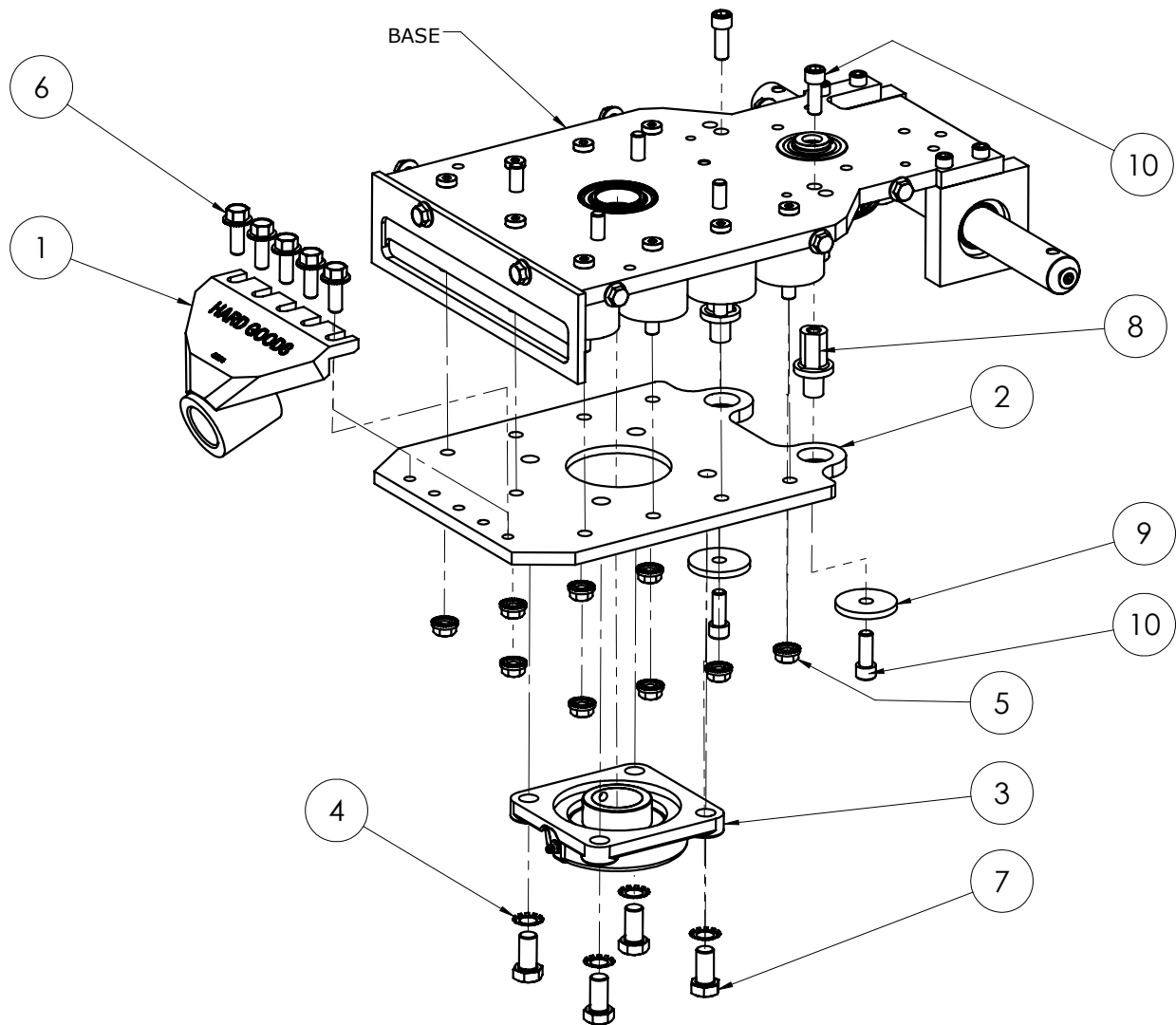

ITEM NO.	PART NO.	DESCRIPTION	QTY.
1	402276	Attachment, Sub, 9 Degree Angle	1
2	6280HD-1	Plate, Base, Cutting Head	1
3	71141	Bearing, 1-7/16" ID 16SC4FB Dodge Housing Assy	1
4	73423	Washer, Interior/Exterior Lock 1/2"	4
5	73211	Nut, Flange, Serrated, 3/8-16	9
6	73222	Bolt, Flange 3/8-16 x 1	5
7	73418	Bolt, Hex Head 1/2-20x1	4
8	402303	Spacer, Stop, Cutting Head, HD	2
9	404167	Stop, Washer, Thrust, Walk Behind	2
10	73266	Bolt, Socket Head Cap 3/8-16x1	4

Parts List and Diagrams

MOTOR ASSEMBLY

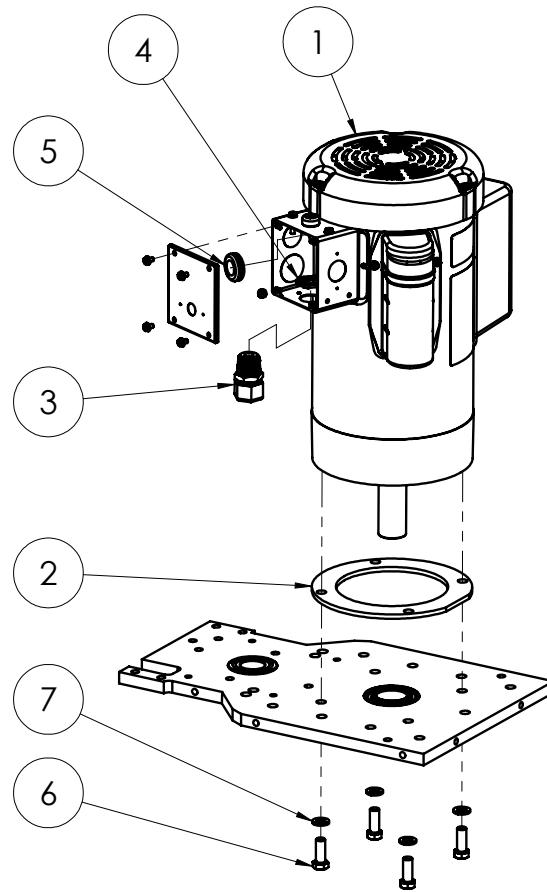

ITEM NO.	6280HD-10XXX 6280HD-12XXX 6280HD-23XXX	6280HD-11XXX 6280HD-13XXX	6280HD-20XXX	DESCRIPTION	QTY.
1	72362	72362		Motor, 1-1/2 HP, 115/230 VAC, 60/50 Hz, 1725/1425 RPM	1
			403307	Motor, 1-1/2 HP, 100 VAC, 50/60 Hz, 1725/1425 RPM	1
2	6280-179	6280-179	6280-179	Ring, Motor Spacer	1
3	73502	73502	73502	Strain Relief, Straight 1/2 Inch, .3376-.5686	1
4	73401	73401	73401	Locknut, Conduit, 1/2"	1
5	74730	74730	74730	Grommet, Rubber 5/8"	1
6	73201	73201	73201	Screw, Hex Head Cap, 3/8-16 x 1	4
7	73204	73204	73204	Washer, Lock, 3/8	4
8*	72554			Cord Assembly, Motor, 120 Volt	1
		72554-W	72554-W	Cord Assembly, Motor, 220 Volt	1

*Not shown

Parts List and Diagrams

MOTOR PARTS

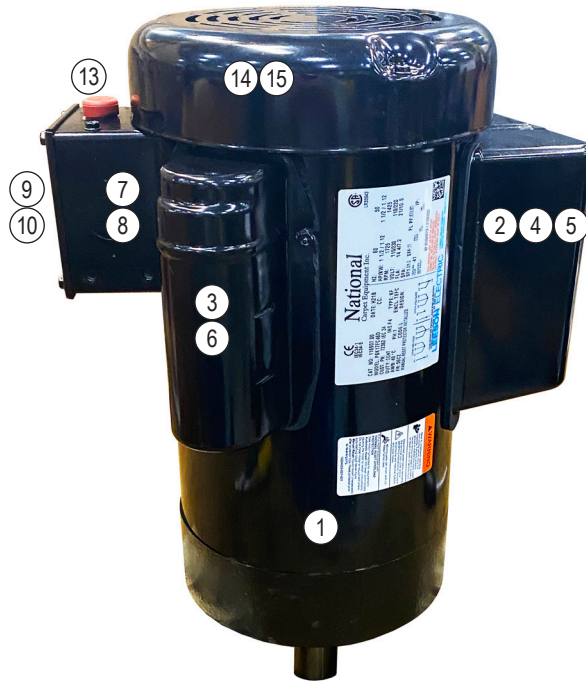

ITEM NO.	6280HD-10XXXX 6280HD-11XXXX 6280HD-12XXXX 6280HD-13XXXX 6280HD-23XXXX	6280HD-20XXXX	DESCRIPTION	QTY.
1	72362		Motor, 1-1/2 HP, 115/230 VAC, 60/50 Hz, 1725/1425 RPM	1
		403307	Motor, 1-1/2 HP, 100 VAC, 50/60 Hz, 1725/1425 RPM	1
2	6280HD-202		Capacitor, Motor (Run)	2
		NA	Capacitor, Motor (Run)	1
3	6280HD-203		Capacitor, Motor (Start)	1
4		NA	Capacitor, Motor (Start)	1
5	6280-150	6280-150	Cover, Capacitor	1
6	62182		Cover, Capacitor, Leeson	1
7	401698	401698	Box, Junction, Motor, 3" x 3.3"	1
8	401869	401869	Gasket, Frame, Junction Box, 3x3.33"	1
9	401699	401699	Cover, Junction Box, Motor, 3" x 3.3"	1
10	401870	401870	Gasket, Cover, Junction Box, 3x3.33"	1
11*	6280-147-1	NA	Switch, Starter	1
12*	6280-147-2	NA	Actuator, Starter Switch	1
13	72461	NA	Switch, Thermo Overload	1
14	62181	62181	Fan, Motor	1
15	400001	400001	Cover, Motor Fan, Top Mount Screws, Painted	1

*Not shown

Parts List and Diagrams

PUMP

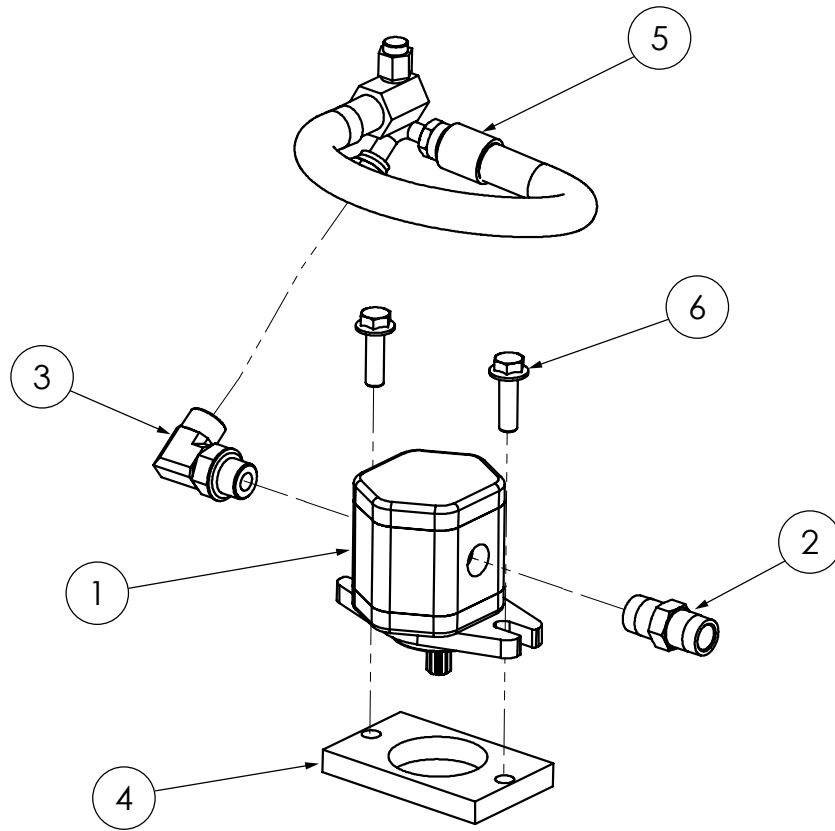

ITEM NO.	6280HD-10XXXX 6280HD-12XXXX 6280HD-20XXXX 6280HD-23XXXX	6280HD-11XXXX 6280HD-13XXXX	DESCRIPTION	QTY.
1	6280-113S		Pump, Spline, #4	1
		70925	Pump, Hydraulic, Single #7, Splined	1
2	6280-117	6280-117	Fitting, Pump	1
3	6280-118	6280-118	Adapter, Hydraulic, 90 deg, -8M ORFS, -8M ORB	1
4	6280-119	6280-119	Spacer, Pump	1
5	6280-120	6280-120	Suction Hose	1
6	73223	73223	Bolt, Wizlock, 3/8-16x1-1/4	2

Parts List and Diagrams

HYDRAULIC MOTOR ASSEMBLY 6280HD-HYDMOTOR

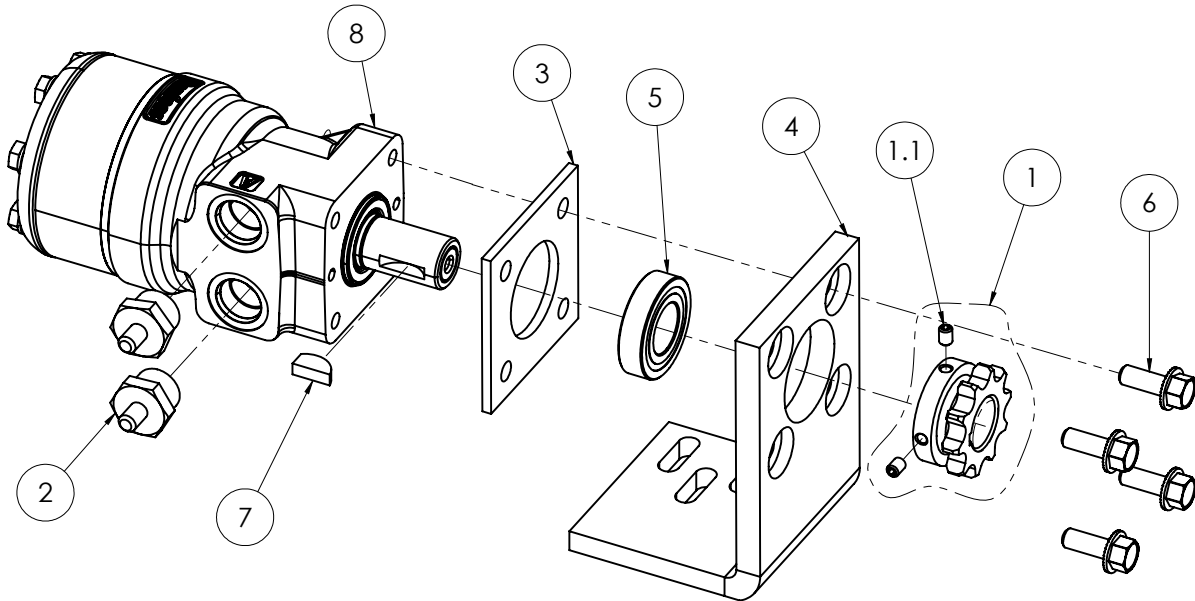

ITEM NO.	PART NO.	DESCRIPTION	QTY.
1	401541	Sprocket, Axle, Heavy Duty	1
1.1	73012	Screw, Set, Cup Point, 1/4-20x3/8	2
2	6280-221	Connector, Hydraulic Motor	2
3	6280-225	Spacer, Hydraulic Motor	1
4	6280-226	Bracket, Mounting, Hydraulic Motor	1
5	71115	Bearing, Ball, 1 x 2 x .5	1
6	73222	Bolt, Flange 3/8-16 x 1	4
7	6280-223	Key, Shaft, Hydraulic Motor	1
8	405966	Motor, Hydraulic, 250CCM	1

Parts List and Diagrams

ECENTRIC, CHAIN AND BELT

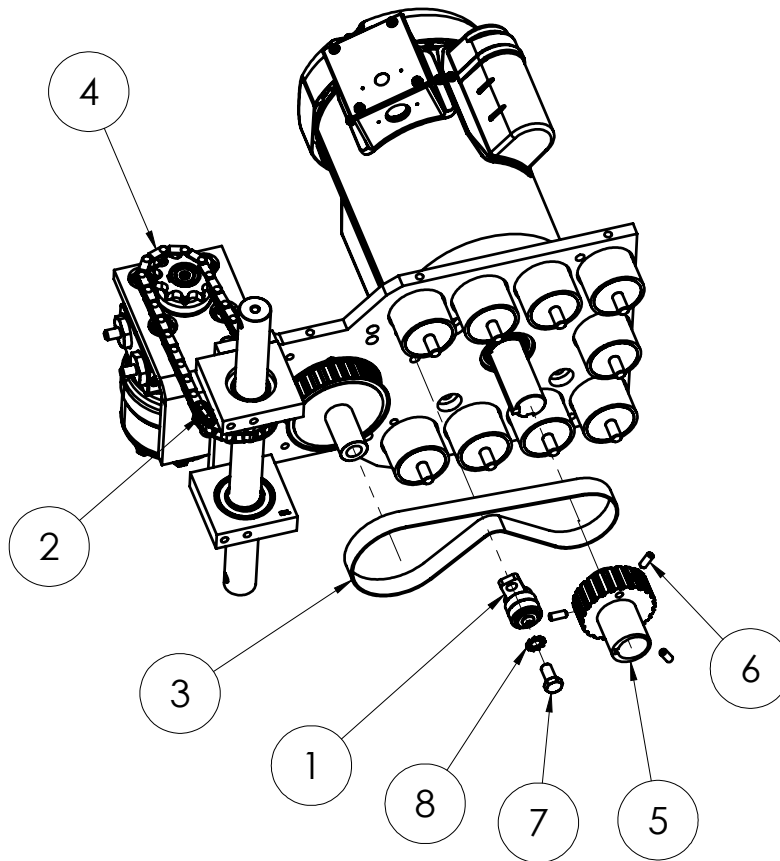

ITEM NO.	PART NO.	DESCRIPTION	QTY.
1	6280-125	Assembly, Idler	1
2	6280-229	Link, Master, Drive Chain	1
3	6280HD-108	Belt, Pump Drive	1
4	6280HD-228	Chain, Drive, #50 Strand, 31p, with Link	1
5	6280HD-400	Eccentric	1
6	73044	Screw, Cup Point Socket Set 1/4-20 x 5/8	3
7	73218	Screw, Hex Head Cap, 3/8-24x3/4	1
8	73215	Washer, External Lock 3/8	1

Parts List and Diagrams

IDLER ASSEMBLY 6280-125

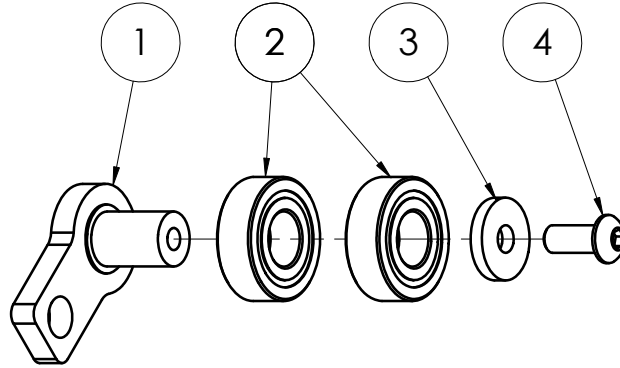

ITEM NO.	PART NO.	DESCRIPTION	QTY.
1	6280-125W	Bracket and Pin, Idler Mount	1
2	71072	Bearing, 1/2 ID DCTN-1616	2
3	6280-126A	Cap, Idler Bearing	1
4	73003	Screw, Button Head Socket Cap, 1/4-20x5/8	1

Parts List and Diagrams

BOTTOM AND BACK COVERS

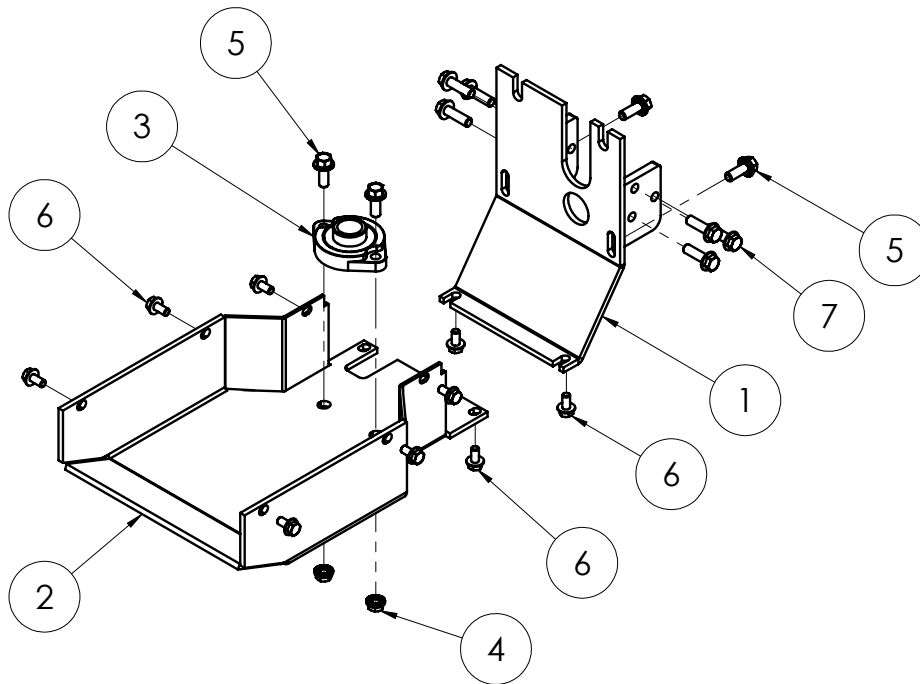

ITEM NO.	PART NO.	DESCRIPTION	QTY.
1	6280-139	Cover, Rear	1
2	6280HD-138	Cover, Main Bottom	1
3	71118	Bearing, Flange	1
4	73211	Nut, Flange, Serrated, 3/8-16	11
5	73222	Bolt, Flange 3/8-16 x 1	14
6	73318	Bolt, Wizlock Flange 5/16-18x5/8	10
7	73223	Bolt, Wizlock, 3/8-16x1-1/4	8

Parts List and Diagrams

WHEELS

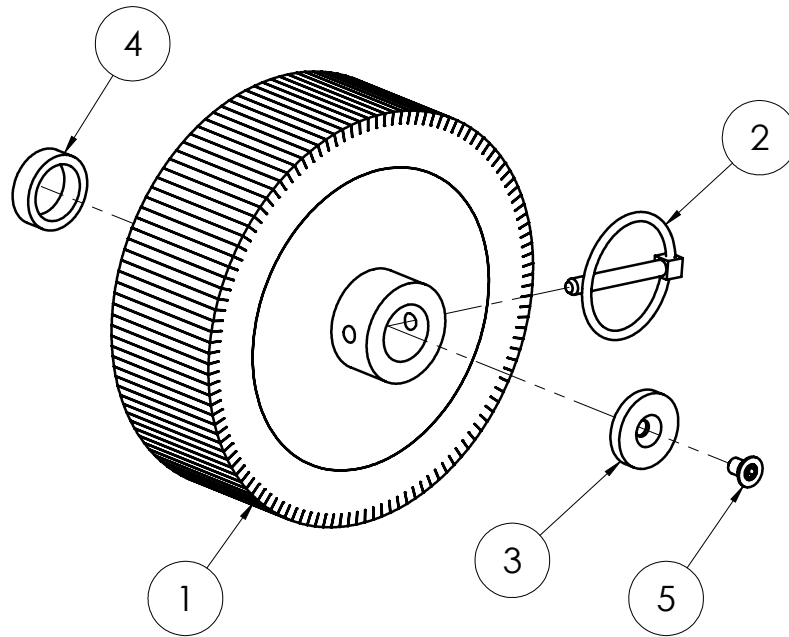

ITEM NO.	PART NO.	DESCRIPTION	QTY.
1	402592	Wheel, Drive, Siped, Heavy Duty, 8.25 x 2.75	2
2	402311	Pin, Lynch, 5/16 x 2-1/16	2
3	6280-112	Cap, Wheel	2
4	6280HD-112	Spacer, Wheel	2
5	73313	Screw, Flat Head Socket Cap 5/16-18x1/2	2

Parts List and Diagrams

TRANSPORT WHEEL ASSEMBLY 6280HD-250

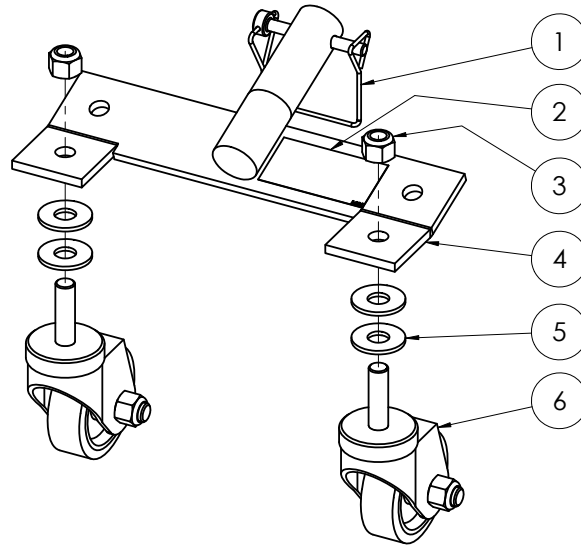

ITEM NO.	PART NO.	DESCRIPTION	QTY.
1	73330	Pin, Locking, 5/16" x 2"	1
2	L191	Label Caution	1
3	73402	Nut, Hex, Nylon Insert, 1/2-13	2
4	6280HD-300	Bracket, Transport Wheels	1
5	73425	Washer, Flat USS Zinc 1/2	4
6	6280-301	Caster Assy, Swivel, 4", Stem	2

Parts List and Diagrams

HANDLE ASSEMBLY

401577 (DOMESTIC)—SHOWN

404581-XXX (INTERNATIONAL)

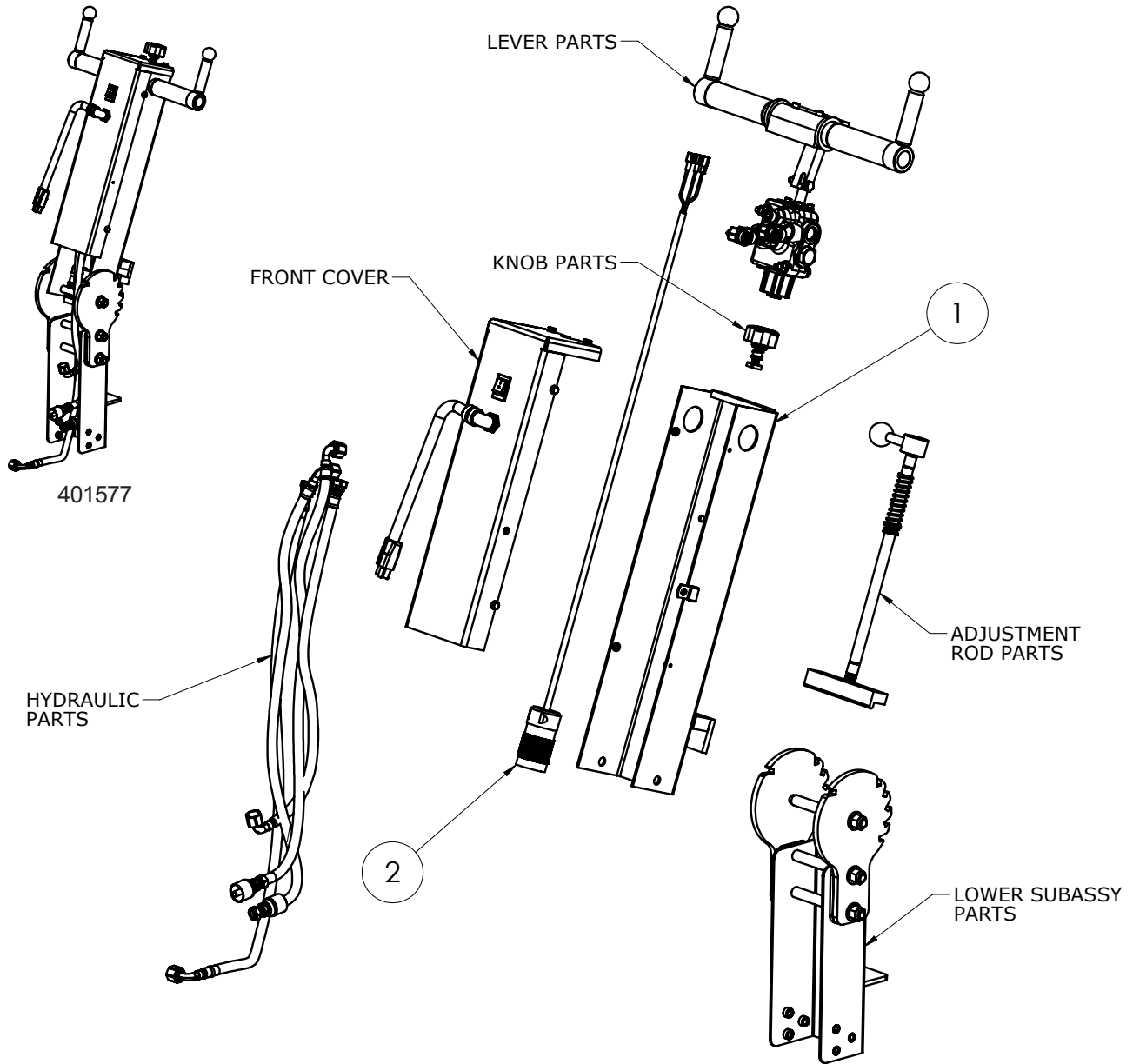

ITEM NO.	6280HD-10XXXX 6280HD-12XXXX 6280HD-23XXXX	6280HD-11XXXX 6280HD-13XXXX 6280HD-20XXXX	DESCRIPTION	QTY.
1	6280-601	6280-601	Weldment, Upper Handle	1
2	401588		Cord, Handle, Commander, 6280, 110V	1
		404583-033	Assembly, Cord, Handle, 2.5mm/3, NEMA L6-15R, 33"	1

Parts List and Diagrams

FRONT COVER (DOMESTIC)

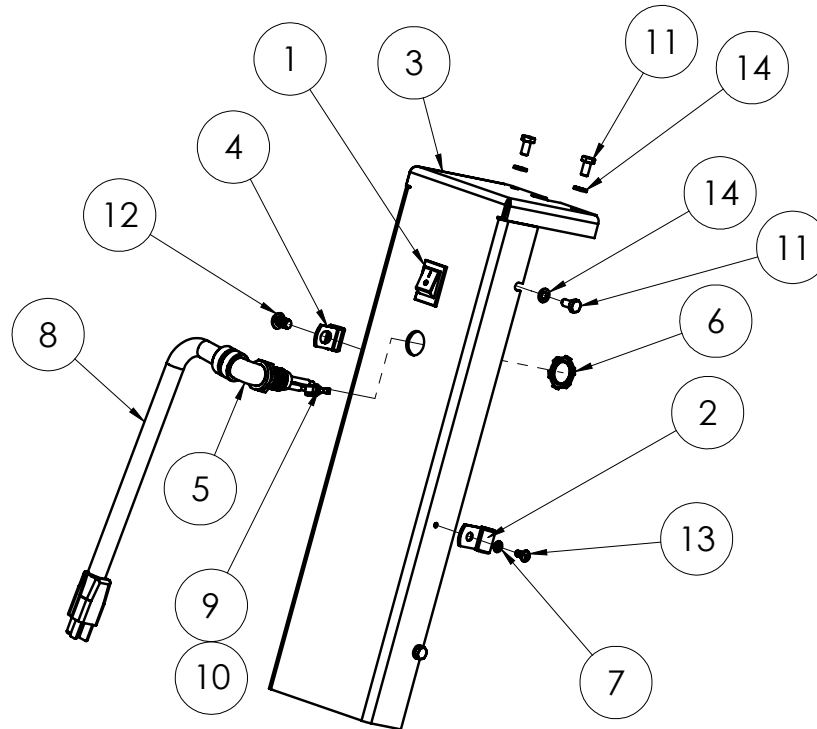

ITEM NO.	6280HD-10XXXX 6280HD-12XXXX 6280HD-23XXXX	DESCRIPTION	QTY.
1	6280-207	Switch, On-Off	1
2	72837	Clamp, Cable, Vinyl Coated, 5/16	1
3	6280-602	Cover, Upper Handle	1
4	72873	Clamp, Cable, Vinyl Coated, 3/8	1
5	401682	Connector, 1/2", 90 Degree	1
6	73401	Locknut, Conduit, 1/2"	1
7	74413	Washer, Internal Lock #10	1
8	6280-168	Cord, Power, SJTOW, 12/3, NEMA 5-15, Yellow, 30in	1
9	405215	Terminal, QC, Flag, Yellow Nylon, .250, 10-12AWG	2
10	72812	Terminal, QC, Female, Yellow Nylon, .250, 10-12AWG	1
11	74630	Bolt, Hex Head Cap M6-12 8.8	6
12	73301	Bolt, Button Head Socket Cap 5/16-18x1/2	1
13	74406	Screw, Phillips Pan Head 10-32x3/8	1
14	74619	Washer, Lock, M6	6

Parts List and Diagrams

FRONT COVER (INTERNATIONAL)

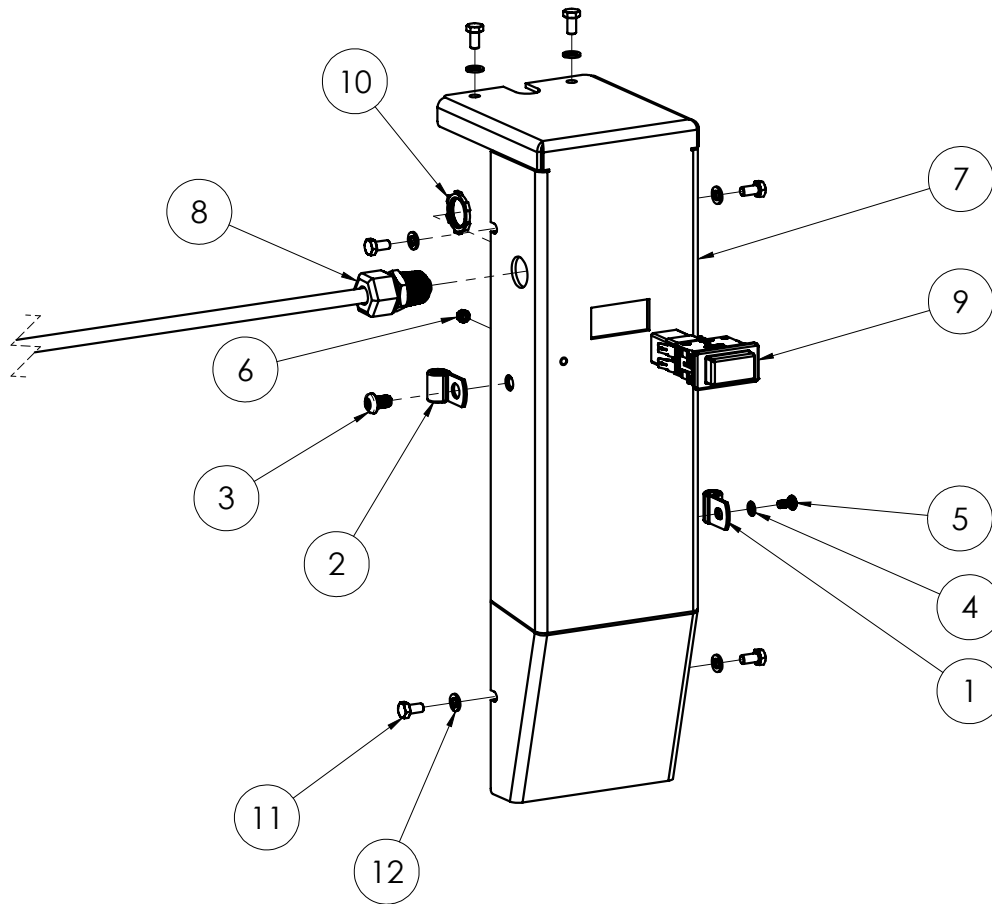

ITEM NO.	6280HD-11XXXX	6280HD-13XXXX	6280HD-20XXXX	DESCRIPTION	QTY.
1	72837	72837	72837	Clamp, Cable, Vinyl Coated, 5/16	1
2	72873	72873	72873	Clamp, Cable, Vinyl Coated, 3/8	1
3	73301	73301	73301	Screw, Button Head Socket Cap, 5/16-18x1/2	1
4	74413	74413	74413	Washer, Internal Lock #10	1
5	74406	74406	74406	Screw, Phillips Pan Head, 10-32x3/8	1
6	403281	403281	403281	Nut, Keps, M4-0.7, Clear Zinc	1
7	404318	404318	404318	Cover, Upper Handle, CE	1
8	404172			Assembly, Cord, Power, 1.5mm/3, EU1-16P, 15in	1
		404173		Assembly, Cord, Power, 1mm/3, AUS1-16P, 15in	1
			404171	Assembly, Cord, Power, 2.5mm/3, IEC 309 110V/16A, 50ft	1
9			404144	Switch, Rocker Breaker, 18A, 90-120V, UVR	1
	404180	404180		Switch, Rocker Breaker, 10A, 220-240V, UVR	1
10			73401	Locknut, Conduit, 1/2"	1
11	74630	74630	74630	Screw, Hex Head Cap, M6-12 8.8	6
12	74619	74619	74619	Washer, Lock, M6	6

Parts List and Diagrams

LOWER SUB-ASSEMBLY

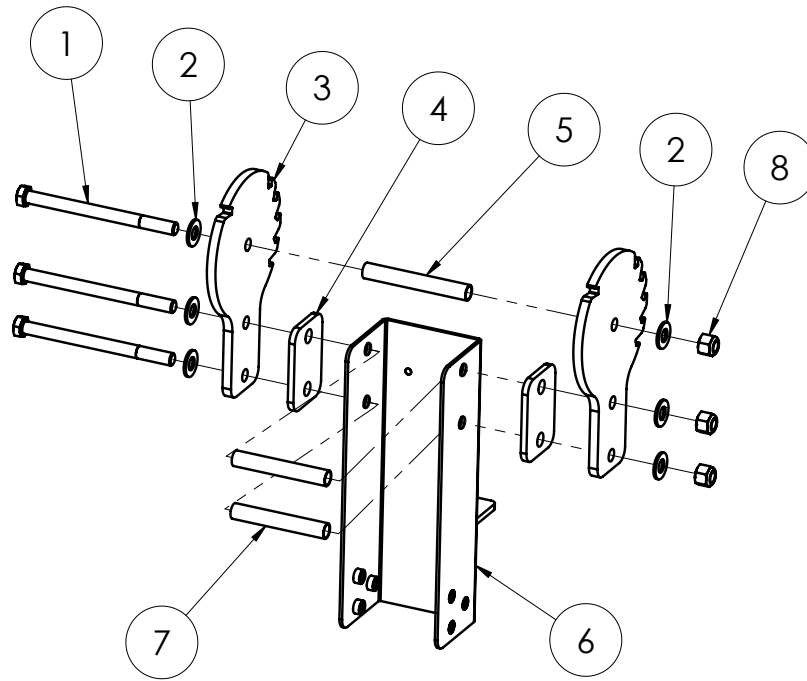

ITEM NO.	PART NO.	DESCRIPTION	QTY.
1	400056	Screw, Hex Head Cap, 1/2-13x6-1/2	3
2	73424	Washer, Flat, Zinc SAE 1/2	6
3	6280-600	Plate, Index, Handle	2
4	400077	Gasket, Handle	2
5	6280-618	Tube, Spacer, Long	1
6	401629	Handle, Lower, Rack Pins	1
7	6280-619	Spacer Tube, Short	2
8	73402	Nut, Hex, Nylon Insert, 1/2-13	3

Parts List and Diagrams

HYDRAULIC HOSES

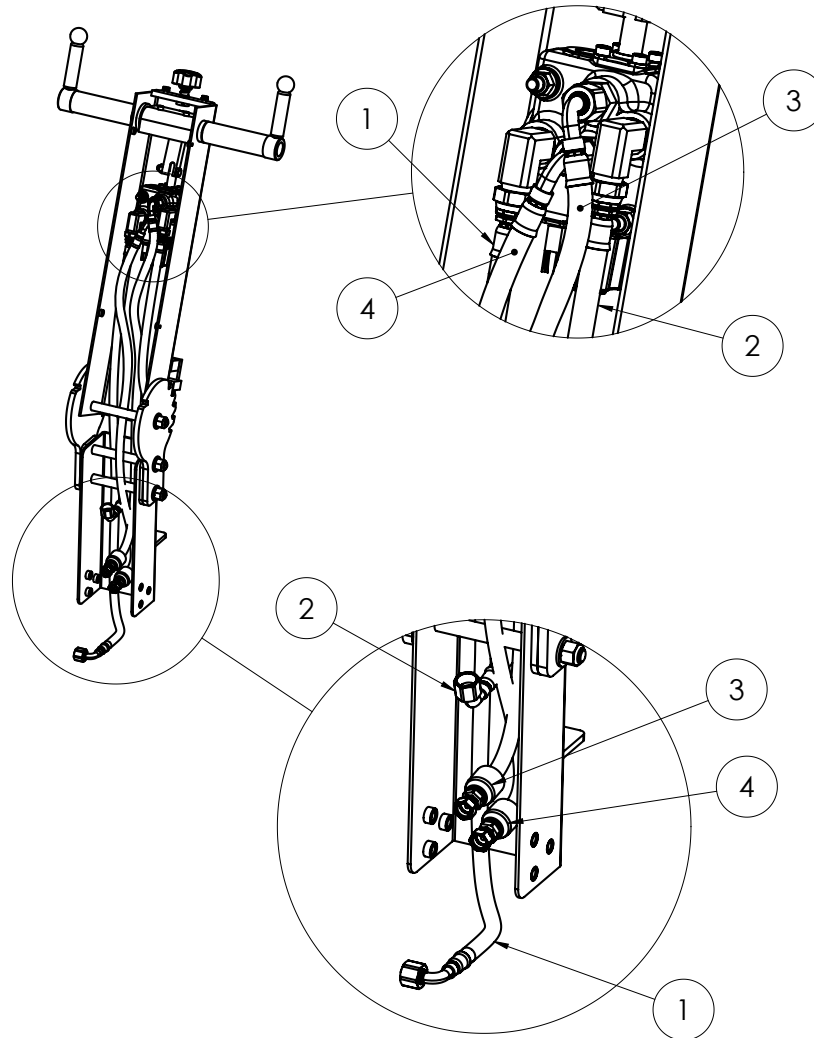

ITEM NO.	PART NO.	DESCRIPTION	QTY.
1	400031	Hose, Hydraulic, 1/4 x 40, F/90F	1
2	400033	Hose, Hydraulic, 3/8 x 36, F/F	1
3	400032	Hose, Hydraulic, 1/4 x 33, F/90F	1
4	400032	Hose, Hydraulic, 1/4 x 33, F/90F	1
5*	400097	Wrap, Kevlar	21"

*Not shown

Parts List and Diagrams

LEVER

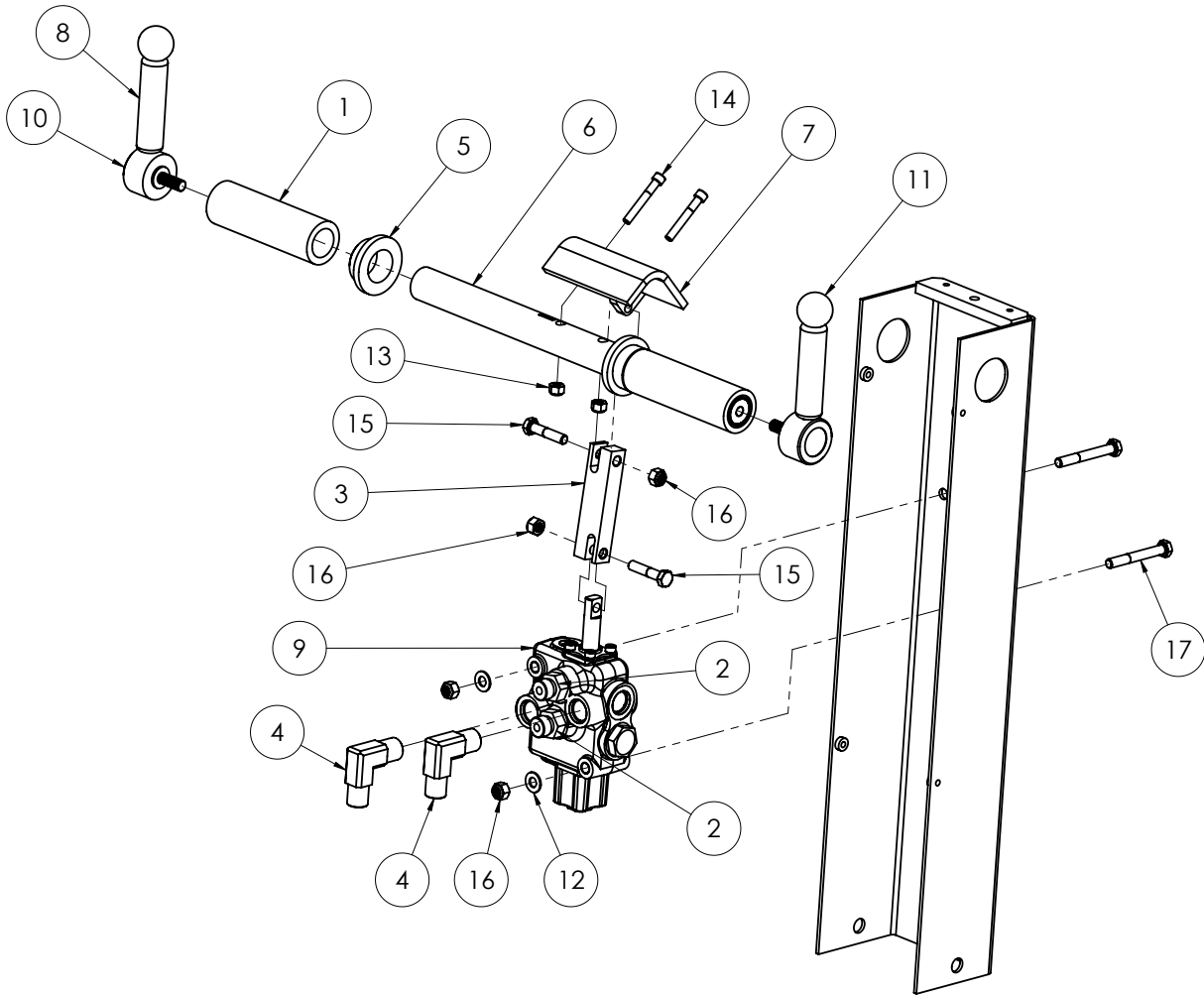

ITEM NO.	PART NO.	DESCRIPTION	QTY.
1	400024	Grip, Foam, 1"	2
2	400034	Fitting, FF1231-06-08	2
3	401434	Linkage, Valve, Handle	1
4	5280-118	Adapter, Hydraulic, 90 Deg, -6M ORFS, -8M ORB	2
5	6280-607	Bushing, Handle Bar	2
6	6280-608	Weldment, Handle Bar	1
7	6280-613	Bracket, Valve Connector	1
8	70623	Grip, Foam	2
9	70624	Valve, Single Spool, Tapered	1
10	70636	Lever, Adjustable, Right Hand	1
11	70637	Lever, Adjustable, Left Hand	1
12	73351	Washer, Flat, 5/16, SAE	2
13	73008	Nut, Hex, Nylon Insert, 1/4-20	2
14	73066	Bolt, SHCS, 1/4-20x1.75	2
15	73334	Bolt, Hex Head Cap 5/16-18x1-1/2	2
16	73322	Nut, Hex, Nylon Insert, 5/16-18	4
17	73327	Bolt, Hex Head Cap 5/16-18x2 1/2	2

Parts List and Diagrams

ADJUSTMENT ROD

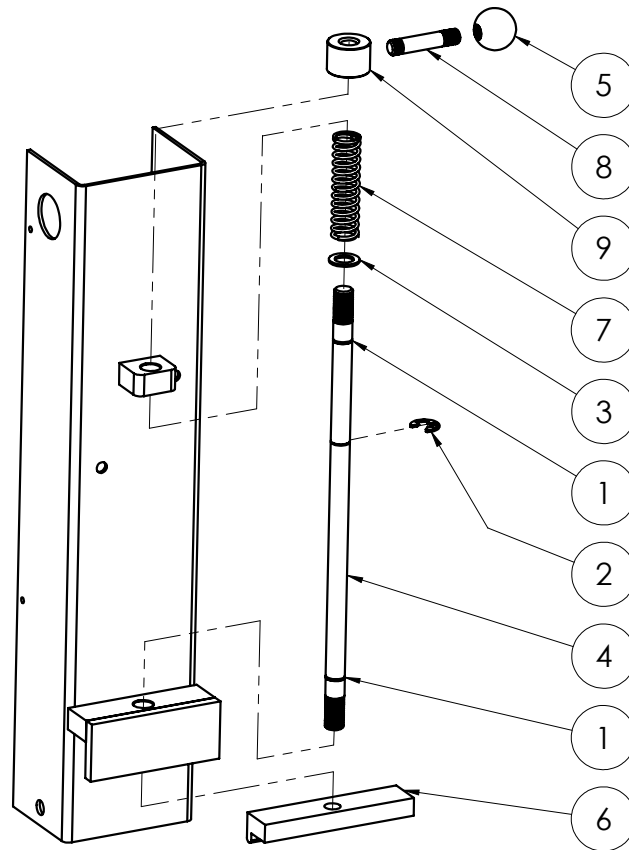

ITEM NO.	PART NO.	DESCRIPTION	QTY.
1	402197	O-ring, .489 ID X .629 OD X .070 W	2
2	402200	E-Clip, Shaft, .625	1
3	402201	Washer, .625 ID x 1.000 OD	1
4	402219	Rod, Adjustment, Large, 3X Groove	1
5	6280-606	Handle, Ball	1
6	6280-611	Lock, Adjustment Bar	1
7	92800-12	Spring, Adjustment, 3.5"	1
8	92800-98	Rod, Adjustment, Short	1
9	92800-99	Collar, Adjustment Rod	1

Parts List and Diagrams

SPEED CONTROL KNOB

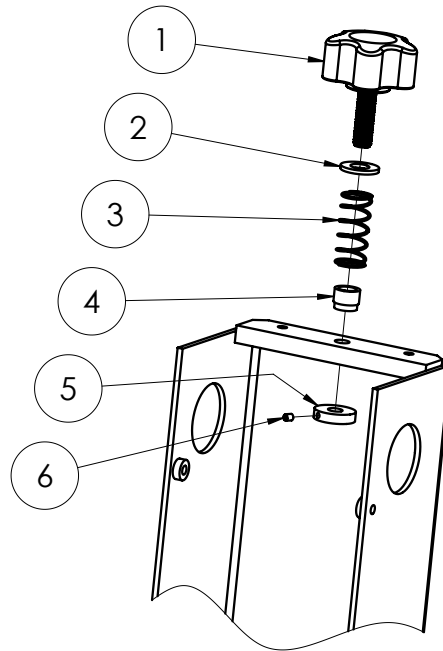

ITEM NO.	PART NO.	DESCRIPTION	QTY.
1	70638	Knob, Adjustable, 1-1/4"	1
2	73263	Washer, Flat SAE Zinc 3/8	1
3	402290	Spring, .66"OD x 1.50"L x .049"w	1
4	402256	Sleeve, Knob, Commander Handle	1
5	401997	Stopper, Speed Control	1
6	404735	Screw, Set, Cup, 6-32 x 1/4, Black Oxide w/ Patch	1

Parts List and Diagrams

LABELS

ITEM NO.	PART NO.	DESCRIPTION	QTY.
1	403360-XX*	Kit, Labels, 6280HD-COM, [Language]	1
2	402627	Label, Private, 1.5 x 2 (6280HD-23XXXX Only)	2
3	402628	Label, Private, 3.5 x 5.5 (6280HD-23XXXX Only)	2

*Suffix (-XX) denotes language: None=English; -FR=French; -NL=Dutch; -DE=German.

Parts List and Diagrams

WIRING DIAGRAM (120V DOMESTIC)

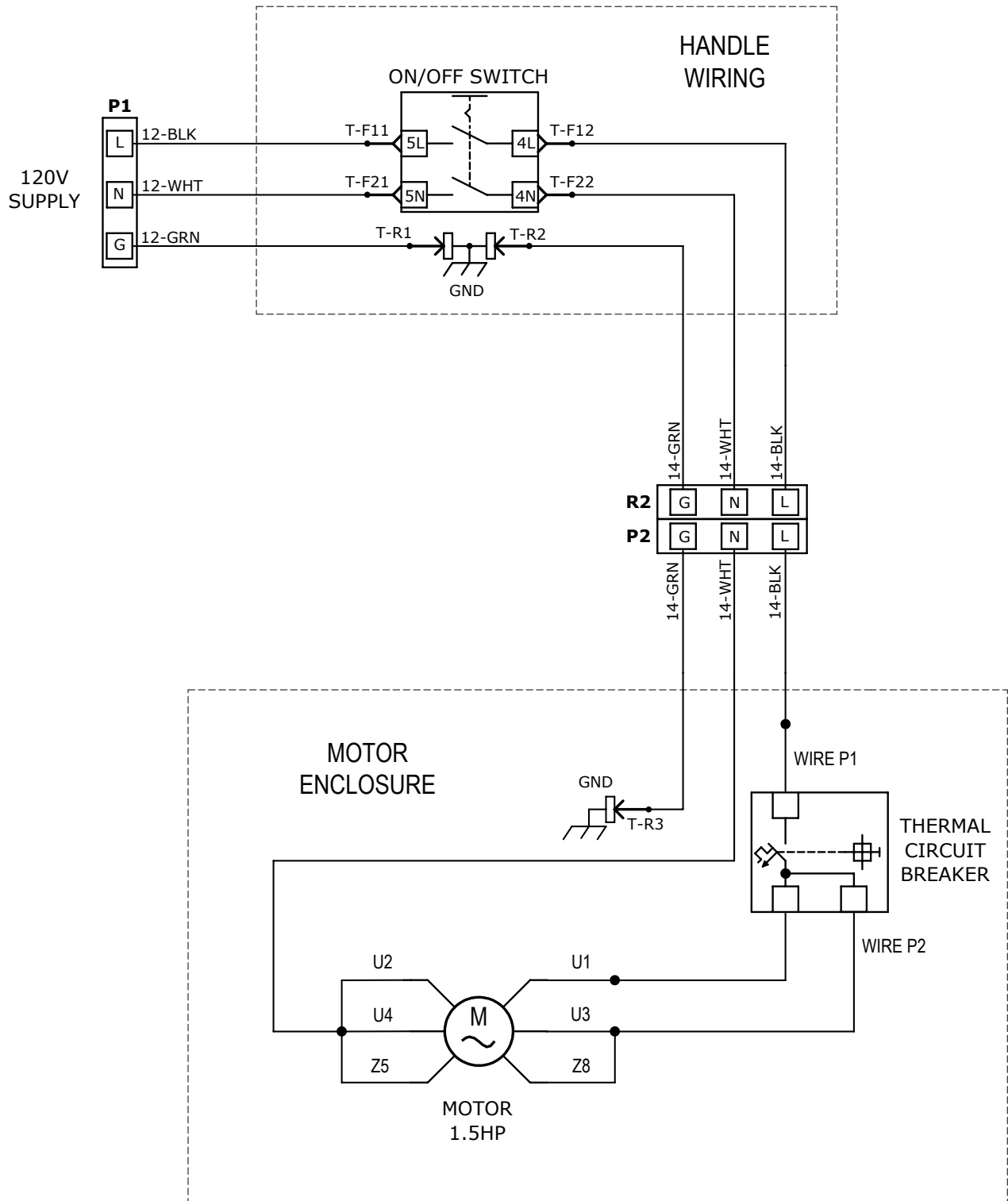

Parts List and Diagrams

WIRING DIAGRAM (230V INTERNATIONAL)

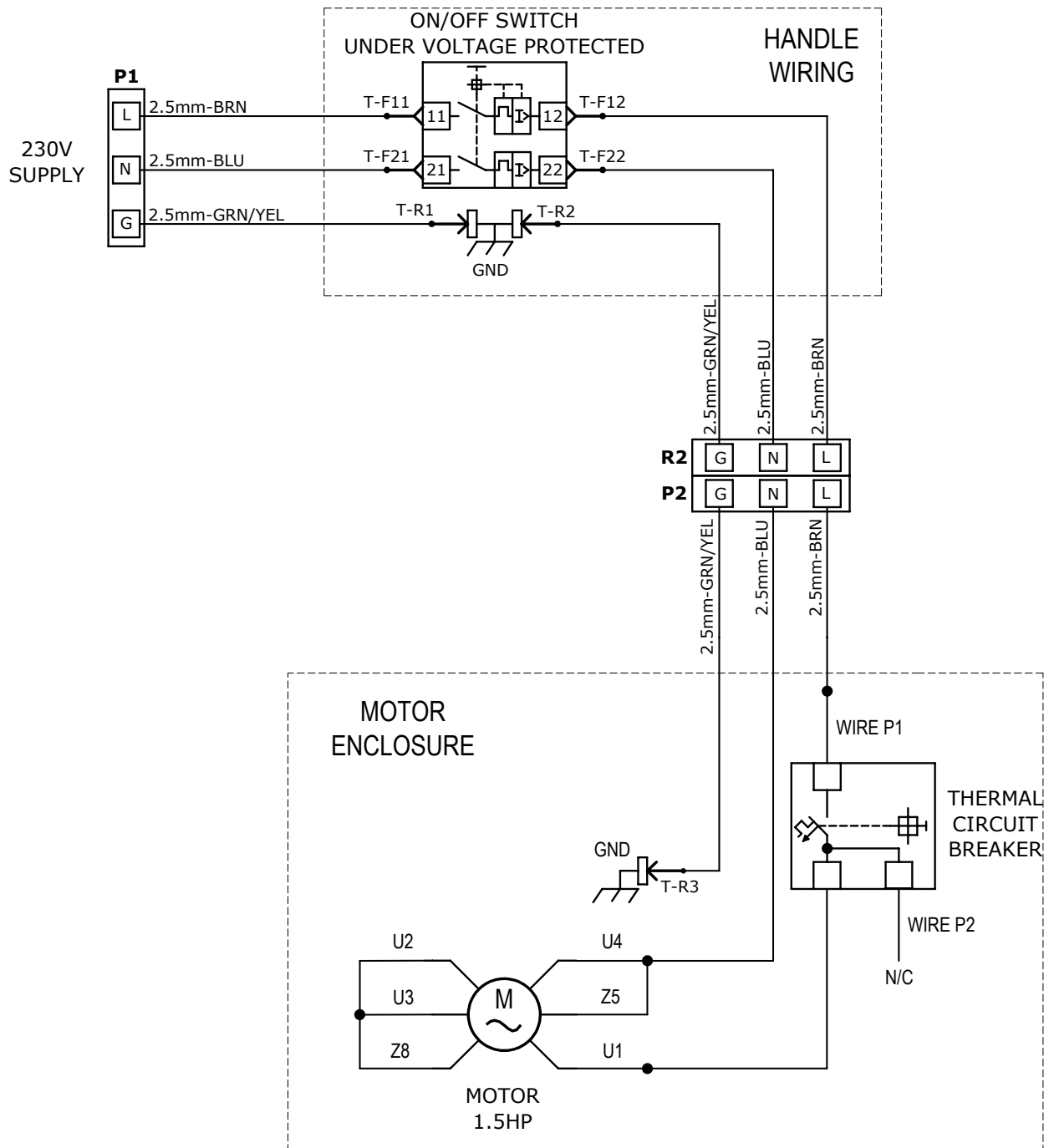

Parts List and Diagrams

WIRING DIAGRAM (100V-110V INTERNATIONAL)

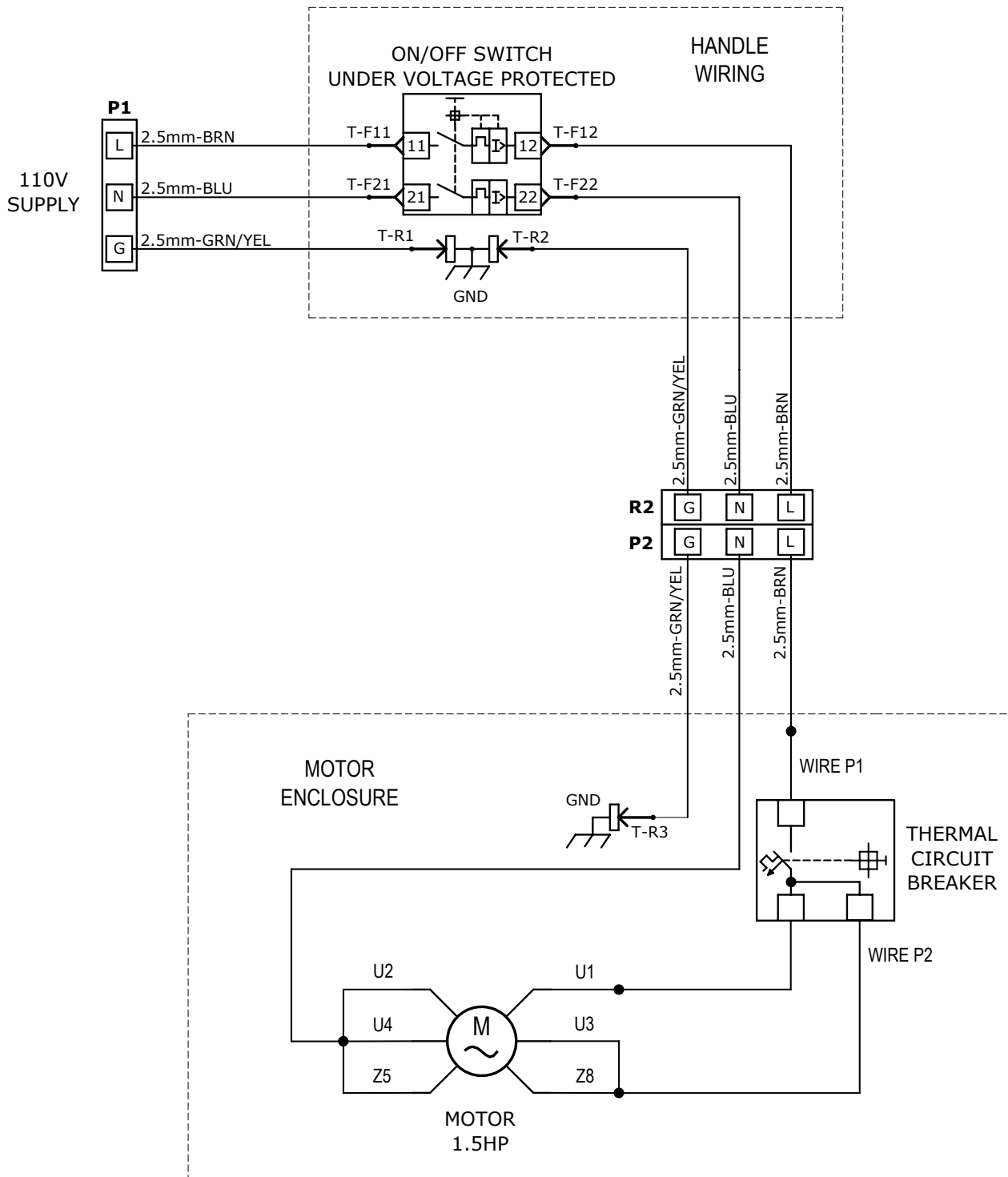

Parts List and Diagrams

HYDRAULICS

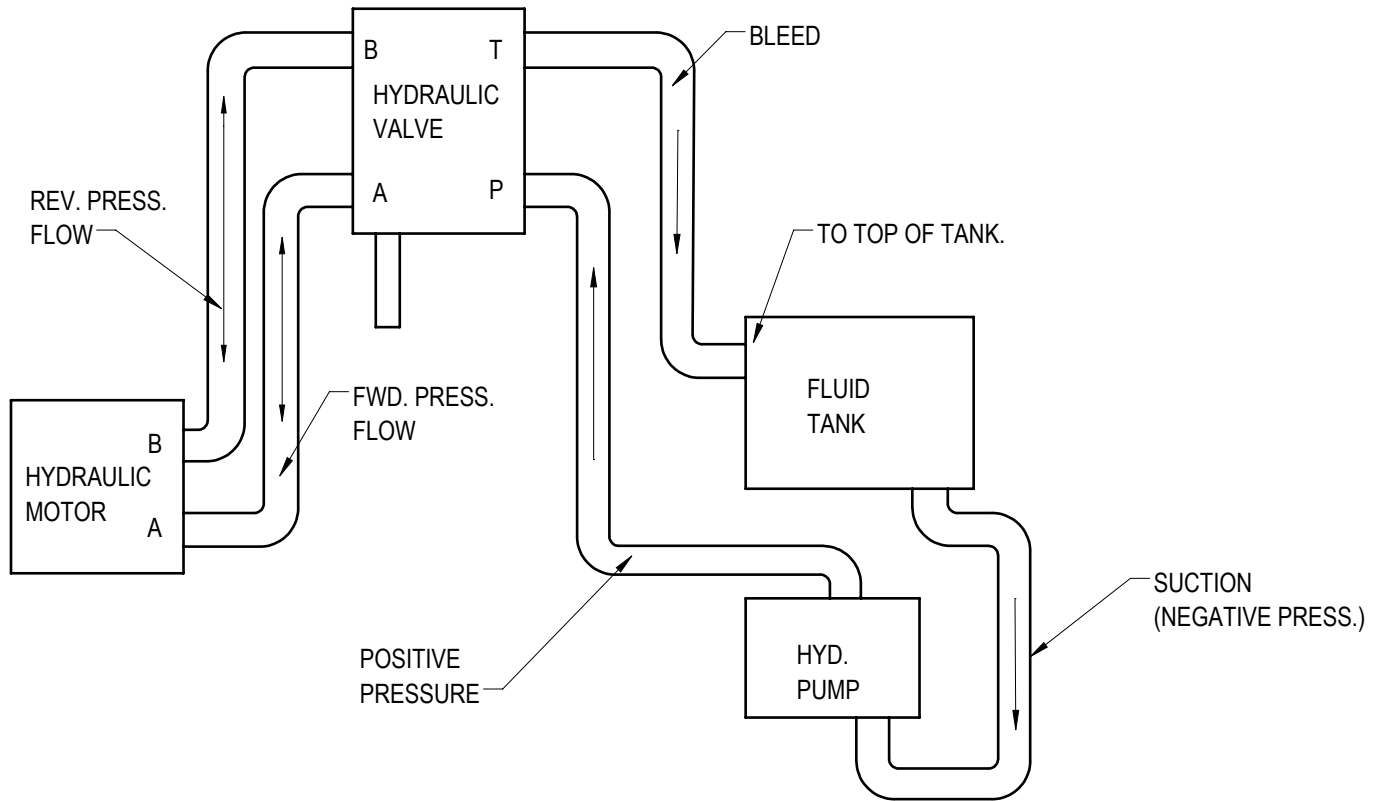

Warranty

National Flooring Equipment Inc. (referred to as "The Company") warrants that each new unit manufactured by The Company to be free from defects in materials and workmanship in normal use and service for a period of twelve (12) months from date of shipment from The Company to the end user. If shipment to end user is from a Distributor, The Company may honor warranty for up to 15 months from initial shipment from the Company if the end user can provide documentation of receipt date. Accessories or equipment furnished and installed on the product by the Company but manufactured by others, including but not limited to: engines, motors, electrical components, transmissions etc., shall carry the accessory manufacturers own warranty. Battery warranties are prorated over the warranty period. Customer is responsible for the inspection of equipment or parts upon delivery. **Freight damages are excluded from this warranty.**

The Company, at its determination of defect, will repair or replace any product or part deemed to be defective in material or workmanship within specified warranty time period. All product determinations and / or repairs will take place at The Company repair facility or at a certified warranty location designated by The Company. The Company will coordinate and be responsible for all freight expenses associated with valid warranty claims. Freight and shipping expenses associated with abuse or misuse will be back charged to the Distributor/Customer. The Company reserves the right to modify, alter or improve any part / parts without incurring any obligation to replace any part / parts previously sold without such modified, altered or improved part / parts. In no event shall the seller or manufacturer of the product be liable for special, incidental, or consequential damages, including loss of profits, whether or not caused by or resulting from the negligence of seller and / or the manufacturer of the product unless specifically provided herein. **This warranty shall not apply to any products or portions there of which have been subjected to abuse, misuse, improper installation or operation, lack of recommended maintenance, electrical failure or abnormal conditions, and to products which have been tampered with, altered, modified, repaired, reworked by anyone not approved or authorized by the Company or used in any manner inconsistent with the provisions of the above or any instructions or specifications provided with or for the product.** Any and all unauthorized onsite warranty work conducted by unauthorized personnel or any outside person(s), is not covered by The Company unless the work has been pre-authorized by a predetermined manufacturer representative. This warranty excludes wearable parts and/or consumables.

Defective or failed material or equipment shall be held at the purchaser's premises until authorization has been granted by The Company to return or dispose of defective products. Products returned to The Company for inspection must be returned with a manufacturer authorized Return Material Authorization (RMA), and must be packaged to The Company's specifications to avoid damage during shipment. Any unauthorized return of equipment will be declined at the dock by The Company. Any non-approved items returned with approved returned items are subject to rejection and will not be credited. Credit will be issued for material found to be defective upon The Company's inspection based on prices at time of purchase.

TO OBTAIN SERVICE CONTACT NATIONAL FLOORING EQUIPMENT, INC. TOLL FREE AT 800-245-0267 FOR A REPAIR AUTHORIZATION NUMBER. COD FREIGHT RETURNS WILL NOT BE ACCEPTED. FREIGHT COLLECT SHIPMENTS WILL NOT BE ACCEPTED. WARRANTY REPAIRS MUST BE ACCOMPANIED BY DATE OF PURCHASE RECEIPT AND A RETURN/ REPAIR AUTHORIZATION NUMBER.

RETURN/REPAIR AUTHORIZATION NUMBER: _____

MACHINE SERIAL NUMBER: _____



Made in America Since 1968

9250 Xylon Avenue N • Minneapolis, MN 55445 • U.S.A.
Toll-free 800-245-0267 • Phone 763-315-5300 • Fax 800-648-7124 • Fax 763-535-8255
Web Site: www.nationalequipmentdirect.com • E-Mail: info@nationalequipment.com