

5280 PANTHER[®] WALK-BEHIND SCRAPER OPERATING & SERVICE MANUAL



Read Manual Before Operating or
Servicing Machine

401871 Rev J

Table of Contents

Table of Contents	3
Features & Specifications	4
Safety	5
General Rules for Safe Operation	5
Walk-Behind Scraper Safety Guidelines.....	6
Hydraulic Safety.....	7
Electrical Practices	8
Components and Assembly	10
Transport	10
Preparing Machine for Job.....	11
Operation	12
Operating Controls.....	12
Start-Up Procedure.....	12
Application Setup.....	12
Blade Sharpening	13
Troubleshooting Guide	14
Maintenance	15
Wheel Removal	15
Adding or Changing Hydraulic Fluid	15
Inspection of Internal Parts	15
Tank Removal.....	15
Control Valve Replacement	16
Speed Control Replacement.....	16
Pressure Valve Replacement	16
Forward Switch Replacement.....	16
Power Cord.....	16
Parts List and Diagrams	17
Overall Machine.....	17
Drive Components.....	18
Motor Parts	19
Hydraulic Tank	20
Cutting Head.....	20
Back of Machine	21
Handle	22
Handle (International Only).....	23
Labels	24
Wiring Diagrams	25
Hydraulics.....	28
Warranty	29

Features and Specifications

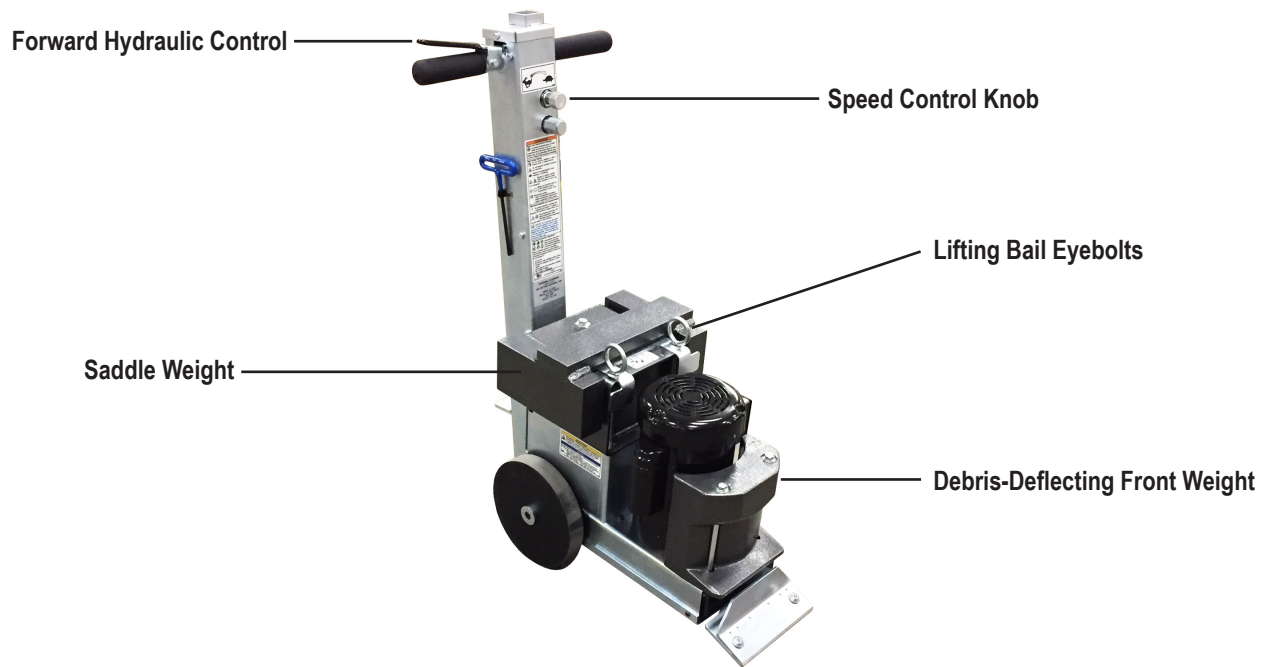

FEATURES

Forward Hydraulic Control- Safely propels the scraper forward.

Lifting Bail Eyebolts- Eases loading/unloading.

Debris-Deflecting Front Weight- Prohibits material and debris from clogging or obstructing production.

Saddle Weight- Provides additional down pressure and traction for tough jobs.

Speed Control Knob - Controls the rate the machine travels forward.

Product Specifications								
Width	Length	Height	Weight (Machine Only)	Weight*	Motor Power	Vibration		
						X Axis	Y Axis	Z Axis
17" (43 cm)	27" (69 cm)	39" (99 cm)	177 lbs (80.3 kg)	263 lbs (119.3 kg)	1.0 HP (.75 kW)	7.8 m/s ²	12.1 m/s ²	14.5 m/s ²

*Includes removable weights.

Machine Variants						
Region	Serial Number	Input Power	Amps (Full Load)	RPM	Speed	Body Panels
Domestic (North America)	5280-10XXXX	120V / 60 Hz	12A	1725	12-50 ft/min	Silver Vein
	5280-23XXXX	120V / 60 Hz	12A	1725	12-50 ft/min	Silver Vein
International	5280-11XXXX	230V / 50 Hz	7A	1425	3.1-12.7 m/min	Silver Vein
	5280-13XXXX	230V / 50 Hz	7A	1425	3.1-12.7 m/min	Silver Vein
	5280-20XXXX	110V / 50 Hz	13A	1425	3.1-12.7 m/min	Silver Vein

GENERAL RULES FOR SAFE OPERATION

Before use, anyone operating or performing maintenance on this equipment must read and understand this manual, as well as any labels packaged with or attached to the machine and its components. Read the manual carefully to learn equipment applications and limitations, as well as potential hazards associated with this type of equipment. Keep manual near machine at all times. If your manual is lost or damaged, contact National Flooring Equipment (NFE) for a replacement.

Personal

Dress properly and use safety gear.

Do not wear loose clothing; it may be caught in moving parts. Anyone in the work area must wear safety goggles or glasses and hearing protection. Wear a dust mask for dusty operations. Hard hats, face shields, safety shoes, etc. should be worn when specified or necessary.

Maintain control; stay alert.

Keep proper footing and balance, and maintain a firm grip. Observe surroundings at all times. Do not use when tired, distracted, or under the influence of drugs, alcohol, or any medication that may cause decreased control.

Keep hands away from all moving parts and tooling.

Wear gloves when changing tooling. Remove tooling when machine is not in use and/or lower cutting head to the floor.

Do not force equipment.

Equipment will perform best at the rate for which it was designed. Excessive force only causes operator fatigue, increased wear, and reduced control.

Environment

Avoid use in dangerous environments.

Do not use in rain, damp or wet locations, or in the presence of explosive atmospheres (gaseous fumes, dust, or flammable materials). Remove materials or debris that may be ignited by sparks. Keep work area tidy and well-lit - a cluttered or dark work area may lead to accidents. Extreme heat or cold may affect performance.

Protect others in the work area and be aware of surroundings.

Provide barriers or shields as needed to protect others from debris and machine operation. Children and other bystanders should be kept at a safe distance from the work area to avoid distracting the operator and/or coming into contact with the machine. Operator should be aware of who is around them and their proximity. Support personnel should never stand next to, in front of, or behind the machine while the machine is running. Operator should look behind them before backing up.

Do not come within 3 ft. of the machine's perimeter during operation.

Guard against electric shock.

Ensure that machine is connected to a properly grounded outlet. Prevent bodily contact with grounded surfaces, e.g. pipes, radiators, ranges, and refrigerators. When scoring or making cuts, always check the work area for hidden wires or pipes.

Maintenance & Repairs

Begin maintenance work only when the machine is shut down, unplugged, and cooled down.

Use proper cleaning agents.

Ensure that all cleaning rags are fiber-free; do not use any aggressive cleaning products.

Schedule regular maintenance check-ups.

Ensure machine is properly cleaned and serviced. Remove all traces of oil, combustible fuel, or cleaning fluids from the machine and its connections and fittings. Retighten all loose fittings found during maintenance and repair work. Loose or damaged parts should be replaced immediately; use only NFE parts.

Do not weld or flame-cut on the machine during repairs, or make changes to machine without authorization from NFE.

Equipment

Use proper parts and accessories.

Only use NFE-approved or recommended parts and accessories. Using any that are not recommended may be hazardous.

Ensure accessories are properly installed and maintained.

Do not permanently remove a guard or other safety device when installing an accessory or attachment.

Inspect for damaged parts.

Check for misalignment, binding of moving parts, loose fasteners, improper mounting, broken parts, and any other conditions that may affect operation. If abnormal noise or vibration occurs, turn the machine off immediately. Do not use damaged equipment until repaired. Do not use if power switch does not turn machine on and off. For all repairs, insist on only identical NFE replacement parts.

Maintain equipment and labels.

Keep handles dry, clean, and free from oil and grease. Keep cutting edges sharp and clean. Follow instructions for lubricating and changing accessories. Motor and switches should be completely enclosed at all times with no exposed wiring. Inspect cord regularly. Labels carry important information; if unreadable or missing, contact NFE for a free replacement.

Avoid accidental starting; store idle equipment.

When not in use, ensure that the machine is unplugged; do not turn on before plugging in. Store in a dry, secured place. Remove tooling when storing, and keep away from children.

Safety

WALK-BEHIND SCRAPER SAFETY GUIDELINES

Before use, anyone operating this equipment must read and understand these safety instructions.

Scraping

Beware of hidden obtrusions.

Watch out for hidden dangers and protrusions in flooring. Do not use on largely uneven surfaces.

Observe location of electrical supplies and extension cords.

Do not allow cutting heads to come into contact with any electrical supply or extension cord.

Use correct tooling and accessories.

Provide barriers or shields as needed to protect others from debris. After mounting tooling, check for proper alignment.

Use for correct applications.

Do not force equipment to do heavier duty work than it was made for.



WARNING: GRINDING/CUTTING/DRILLING OF MASONRY, CONCRETE, METAL AND OTHER MATERIALS CAN GENERATE DUST, MISTS AND FUMES CONTAINING CHEMICALS KNOWN TO CAUSE SERIOUS FATAL INJURY OR ILLNESS, SUCH AS RESPIRATORY DISEASE, CANCER, BIRTH DEFECTS OR OTHER REPRODUCTIVE HARM. IF YOU ARE UNFAMILIAR WITH THE RISKS ASSOCIATED WITH THE PARTICULAR MATERIAL BEING CUT, REVIEW THE MATERIAL SAFETY DATA SHEET AND/OR CONSULT YOU EMPLOYER, THE MATERIAL MANUFACTURER/SUPPLIER, GOVERNMENTAL AGENCIES SUCH AS OSHA AND NIOSH AND OTHER AUTHORITIES ON HAZARDOUS MATERIALS. CALIFORNIA AND SOME OTHER AUTHORITIES, FOR INSTANCE, HAVE PUBLISHED LISTS OF SUBSTANCES KNOWN TO CAUSE CANCER, REPRODUCTIVE TOXICITY, OR OTHER HARMFUL EFFECTS. CONTROL DUST, MIST AND FUMES AT THE SOURCE WHERE POSSIBLE. IN THIS REGARD USE GOOD WORK PRACTICES AND FOLLOW THE RECOMMENDATIONS OF THE MANUFACTURER/SUPPLIER, OSHA/NIOSH, AND OCCUPATIONAL AND TRADE ASSOCIATIONS. WHEN THE HAZARDS FROM INHALATION OF DUST, MISTS AND FUMES CANNOT BE ELIMINATED, THE OPERATOR AND ANY BYSTANDERS SHOULD ALWAYS WEAR A RESPIRATOR APPROVED BY OSHA/MSHA FOR THE MATERIAL BEING CUT.

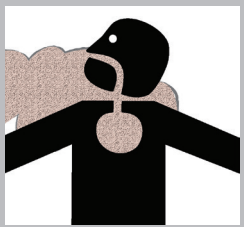

HYDRAULIC SAFETY

Maintaining a Safe Work Environment

Establishing a safe work environment in and around your hydraulic equipment is extremely important. The easiest and most effective way to avoid problems is to make sure associates understand their equipment, know how to operate the machines safely, and recognize the dangers if handled carelessly. A few things to be aware of are:

- **Pressure:** Hydraulic fluid under pressure is dangerous and can cause serious injury. Never look for a leak when unit is under pressure. Using your hand could cause serious injury. A few common ways to encounter hydraulic fluid under pressure include:
 - Pinhole: Fluid under pressure can cause serious injury. It can be almost invisible escaping from a pinhole, and it can pierce the skin into the body.



DANGER: DO NOT TOUCH A PRESSURIZED HYDRAULIC HOSE ASSEMBLY WITH ANY PART OF THE BODY. IF FLUID PUNCTURES THE SKIN, EVEN IF NO PAIN IS FELT, A SERIOUS EMERGENCY EXISTS. OBTAIN MEDICAL ASSISTANCE IMMEDIATELY. FAILURE TO DO SO COULD RESULT IN LOSS OF THE INJURED BODY PART OR DEATH.

- Leak: Keep fittings and hoses tight. Only check and service when not under pressure. Leaking hydraulic fluid is hazardous; in addition to making workplace floors slippery and dangerous, it also contaminates the environment. Before cleaning an oil spill, always check EPA, state, and local regulations.
 - Burst: Whether due to improper selection or damage, a ruptured hose can cause injury. If it bursts, a worker can be burned, cut, injected, or may slip and fall.
 - Coupling Blow-Off: If the assembly is not properly made or installed, the coupling could come off and hit or spray a worker, possibly resulting in serious injury. Never operate machine without guards.
- **Flammability:** When ignited, some hydraulic fluids can cause fires and/or explode. With the exception of those comprised primarily of water, all hydraulic fluid is flammable (including many “fire-resistant” hydraulic fluids) when exposed to the proper conditions. Leaking pressurized hydraulic fluids may develop a mist or fine spray that can flash or explode upon contact with a source of ignition. These explosions can be very severe and could result in serious injury or death. Precautions should be taken to eliminate all ignition sources from contact with escaping fluids, sprays or mists resulting from hydraulic failures. Sources of ignition could be electrical discharges (sparks), open flames, extremely high temperatures, sparks caused by metal-to-metal contact, etc.



CAUTION: NEVER USE YOUR HANDS TO CHECK FOR LEAKS OVER HOSE OR HYDRAULIC CONNECTIONS. USE A PIECE OF CARDBOARD TO LOCATE A PRESSURIZED LEAK. FOR LOW PRESSURE LEAKS (DRIPS), USE A RAG TO CLEAN THE AREA AND DETERMINE WHERE THE LEAK ORIGINATES.

- **Mechanical:** Hydraulic fluid creates movement, which means some equipment may move. Observe surroundings and equipment at all times.
- **Moisture:** Do not use in wet or high moisture conditions.
- **Electrical:** Faulty wiring can be an electrical hazard. A regular preventive maintenance program should always include a wiring check. If applicable, disconnect battery before servicing.
- **Temperature:** Because this machine operates at a relatively low pressure, overheating is not common. If surface of tank becomes too hot to touch by hand (above 130°F or 55°C), shut off machine and allow it to cool.

Hydraulic Fluid

Only use Texaco Rando 46 Hydraulic Oil or compatible fluid like ISO or AW #46 from a brand name manufacturer. Non-compatible fluids could cause damage to unit or serious injury.

Safety

ELECTRICAL PRACTICES



WARNING: ELECTRICAL CORDS CAN BE HAZARDOUS. MISUSE CAN RESULT IN FIRE OR DEATH BY ELECTRICAL SHOCK. READ CAREFULLY AND FOLLOW ALL DIRECTIONS.



CAUTION: ALWAYS FOLLOW APPLICABLE ELECTRICAL CODES, STANDARDS AND/OR REGULATIONS. CONSULT YOUR LOCAL ELECTRICAL AUTHORITY OR A LICENSED ELECTRICIAN BEFORE ATTEMPTING TO MODIFY AN ELECTRICAL INSTALLATION. ENSURE THAT CIRCUIT AND GROUND FAULT PROTECTION DEVICES AND ALL OTHER ELECTRICAL SAFETY EQUIPMENT ARE FUNCTIONING PROPERLY.

Extension Cord Requirements



WARNING: GROUND YOUR EQUIPMENT. THE EQUIPMENT MUST BE PLUGGED INTO AN APPROPRIATE OUTLET, ONE WHICH IS PROPERLY INSTALLED AND GROUNDED IN ACCORDANCE WITH ALL CODES AND ORDINANCES. DO NOT MODIFY THE PLUG PROVIDED WITH THE EQUIPMENT. NEVER REMOVE THE GROUNDING PRONG FROM THE PLUG.



WARNING: DO NOT REMOVE, BEND OR MODIFY ANY METAL PRONGS OR PINS OF THE PLUG. MODIFICATIONS TO POWER CORDS AND/OR PLUGS MAY RESULT IN INJURY AND/OR EQUIPMENT DAMAGE.

- Ensure the cord type is suitable for the application and location. If you are unsure about your cord type, consult a qualified electrical professional or electrician.
- FULLY INSERT plug into outlet.
- Do not use excessive force to make connections.
- Never unplug by pulling the cord from the outlet. Pull plug rather than cord to reduce the risk of damage.
- Regularly examine your extension cord and ensure it is in good electrical condition. Never use a damaged cord—either replace it or have it repaired by a qualified person.
- Protect your extension cords from sharp objects, excessive heat and damp or wet areas. Keep the cord away from oil, cutting edges and moving parts.
- Do not drive, drag or place objects over cord.
- Avoid overheating. Uncoil cord and do not cover it with any material.
- Avoid accidental starting. Be sure equipment is turned off before plugging in. Do not use equipment if the power switch does not turn the equipment on and off.
- Make sure equipment is not running before disconnecting cord.
- Unplug equipment. When not in use and before changing accessories or performing maintenance, unplug the machine.

Extension Cord Selection

All cords should be sized appropriately to reduce the risk of damage, fire or reduced performance. Reference the table in this section for cord sizes.

ELECTRICAL PRACTICES (CONT'D)

How to Use This Table

1. Determine your supply voltage.
2. Determine the total length of your cord including all extension cords.
3. Determine the maximum amp draw for your machine.
4. Trace your voltage across the top of the table to the first length that is greater than or equal to your cord length.
5. Follow the column down to the first row that contains a maximum amp draw greater than or equal to yours.
6. This cell contains the minimum wire size for your application.

Example

Application: Max Amps = 11A, Length = 40ft, Voltage = 120V 1ph

Solution: 40ft is between the 25ft and 50ft columns, so the larger of the two columns is chosen. Likewise, 11A is between the 10A and 12A rows, so the larger of the two rows is chosen. 14 AWG (2.5mm²) is the minimum wire size for this example.

Single Phase Equipment				
Max Length	120V Supply	25ft (7.5m)	50ft (15m)	75ft (22.5m)
	230V Supply	50ft (15m)	100ft (30m)	150ft (45m)
Max Amps		Minimum Wire Size		
8	16 AWG (1.5mm ²)	16 AWG (1.5mm ²)	16 AWG (1.5mm ²)	16 AWG (1.5mm ²)
10	16 AWG (1.5mm ²)	16 AWG (1.5mm ²)	16 AWG (1.5mm ²)	16 AWG (1.5mm ²)
12	14 AWG (2.5mm ²)	14 AWG (2.5mm ²)	14 AWG (2.5mm ²)	14 AWG (2.5mm ²)
14	14 AWG (2.5mm ²)	14 AWG (2.5mm ²)	14 AWG (2.5mm ²)	14 AWG (2.5mm ²)

Extension Cord Sizes

Single Phase Equipment							
Max Length	120V Supply	25ft (7.5m)	50ft (15m)	75ft (25m)	100ft (30m)	150ft (45m)	200ft (60m)
	230V Supply	50ft (15m)	100ft (30m)	150ft (45m)	200ft (60m)	300ft (90m)	400ft (120m)
Max Amps		Minimum Wire Size					
8	16 AWG (1.5mm ²)	16 AWG (1.5mm ²)	16 AWG (1.5mm ²)	16 AWG (1.5mm ²)	16 AWG (1.5mm ²)	14 AWG (2.5mm ²)	14 AWG (2.5mm ²)
10	16 AWG (1.5mm ²)	16 AWG (1.5mm ²)	16 AWG (1.5mm ²)	16 AWG (1.5mm ²)	16 AWG (1.5mm ²)	14 AWG (2.5mm ²)	12 AWG (4mm ²)
12	14 AWG (2.5mm ²)	14 AWG (2.5mm ²)	14 AWG (2.5mm ²)	14 AWG (2.5mm ²)	14 AWG (2.5mm ²)	12 AWG (4mm ²)	12 AWG (4mm ²)
14	14 AWG (2.5mm ²)	14 AWG (2.5mm ²)	14 AWG (2.5mm ²)	14 AWG (2.5mm ²)	14 AWG (2.5mm ²)	12 AWG (4mm ²)	10 AWG (6mm ²)
16	14 AWG (2.5mm ²)	14 AWG (2.5mm ²)	14 AWG (2.5mm ²)	14 AWG (2.5mm ²)	14 AWG (2.5mm ²)	12 AWG (4mm ²)	10 AWG (6mm ²)
18	14 AWG (2.5mm ²)	14 AWG (2.5mm ²)	14 AWG (2.5mm ²)	12 AWG (4mm ²)	12 AWG (4mm ²)	12 AWG (4mm ²)	10 AWG (6mm ²)
20	12 AWG (4mm ²)	12 AWG (4mm ²)	12 AWG (4mm ²)	12 AWG (4mm ²)	12 AWG (4mm ²)	10 AWG (6mm ²)	10 AWG (6mm ²)
25	12 AWG (4mm ²)	12 AWG (4mm ²)	12 AWG (4mm ²)	12 AWG (4mm ²)	12 AWG (4mm ²)	10 AWG (6mm ²)	8 AWG (10mm ²)
30	10 AWG (6mm ²)	10 AWG (6mm ²)	10 AWG (6mm ²)	10 AWG (6mm ²)	10 AWG (6mm ²)	8 AWG (10mm ²)	8 AWG (10mm ²)

Note: The table is based on a <10% voltage loss, data from the U.S. National Electrical Code Tables 400.5(A) & 400.5(B) and typical resistances for copper wire.

Components and Assembly

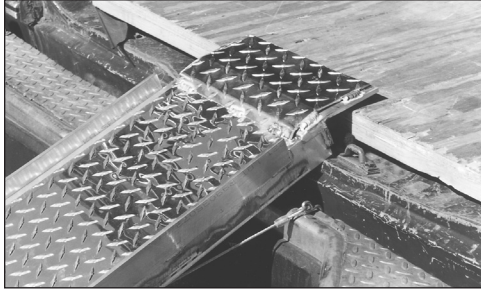

FIG. 1

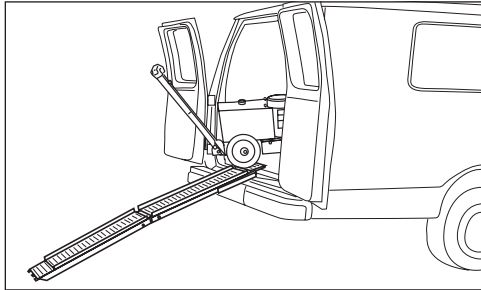

FIG. 2

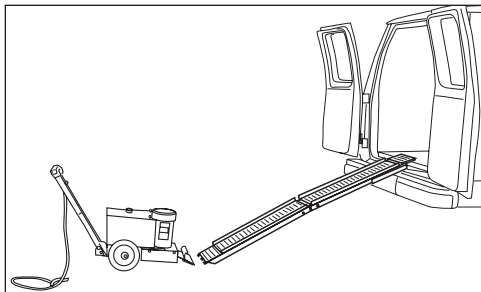

FIG. 3

TRANSPORT

Lifting Bail

The lifting bails make loading/unloading easier when unable to use a ramp.

1. Place rope, hook system, or chain through eyelets located on top of machine.
2. Raise machine with a fork lift or winch.
3. Slowly lower to desired location.

Ramp Loading

1. Ensure ramp is clean and dry, free of grease or oil.
2. Attach ramp securely to back of vehicle, making sure there is good contact
3. Position machine at bottom of ramp.
4. Engage power switch and drive machine up the ramp.

Ramp Unloading

1. Position ramp securely to back of vehicle (Figure 1).
2. Position machine at the back of the truck, in line with the ramp (Figure 2).
3. Carefully move machine onto ramp, leaving cutting head down (in contact with ramp surface). Machine is very heavy, be extremely careful while moving machine.
4. Slowly back machine down ramp (Figure 3).

Components and Assembly

PREPARING MACHINE FOR JOB



WARNING: BLADES ARE SHARP, USE EXTREME CAUTION WHEN HANDLING. ALWAYS WEAR GLOVES AND EYE PROTECTION. NEVER CHANGE CUTTING HEAD OR SERVICE BLADES WHILE MACHINE IS RUNNING.

Blade Setting

Note: This machine is designed to remove soft good materials.

- Depending on material and sub-floor type, proper blade size and placement affect performance.
- For harder jobs, use a smaller blade.
- Start with a narrow blade, then increase blade size to optimize cutting pass. Narrower blades work easier than wider blades and usually clean the floor better. Wider is not always better or faster.
- Normally, bevel on the blade is up for concrete (Figure 4); bevel down for wood (Figure 5).
- Dull blades greatly affect the performance of the machine and reduce cutting ability. Re-sharpen or replace blades as needed.
- Remove any nails or metal obstructions on wood/wood-like flooring prior to use to avoid blade damage.
- Blades can be offset in cutting head for easier access to toe kicks or removal along the wall (Figure 6).
- Sheet vinyl, solid vinyl, rubber tile, urethane, or PVC sheet roofing will need to be scored for best removal results. NFE recommends using a self-scoring blade.
- Self-scoring blades eliminate the need for pre-scoring material. Depending upon the type of material being removed and the sharpness of the blade and scoring wings, the self-scoring blades may make it harder to control the machine. Keep scoring wings sharp at all times.

Blade Changing

1. Place a flat piece of wood under the front of the machine.
2. Use the supplied extended 7/32 "T" wrench (Domestic) or a 6 mm Hex wrench (International) with at least a 3" (76 mm) extension to keep hand safely away from the sharp edge of the blade. Loosen the two Allen head bolts.
3. Place blade into the cutting head and slide back until fully seated against the machined edge. If the blade is wider than the cutting head, center the blade to the head. If the blade is smaller than the cutting head, the blade should be mounted in the center of the cutting head during the first pass. After the first pass is made, the blade can be offset in the head to allow the wheels to keep even contact with the floor and provide easy access to the wall.
4. Tighten the bolts.

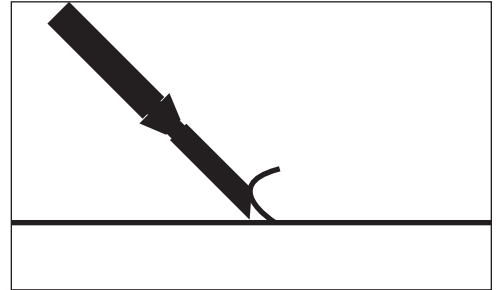

FIG. 4

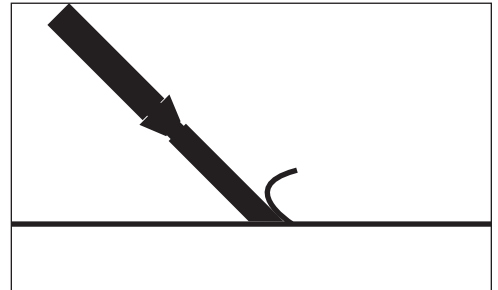

FIG. 5



FIG. 6

Operation

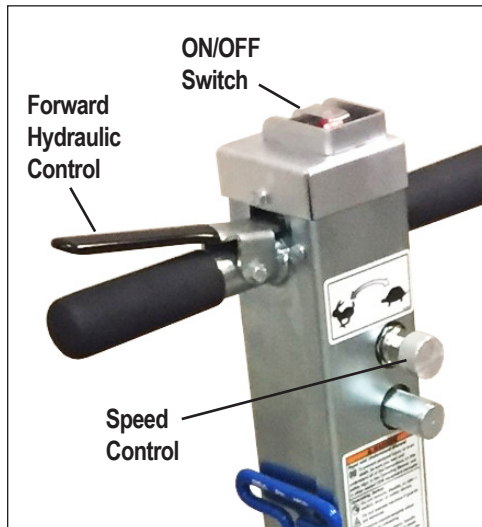

FIG. 7

OPERATING CONTROLS (FIGURE 7)

Speed Control

- Turning speed control knob clockwise (towards turtle) decreases forward speed.
- Turning speed control knob counterclockwise (towards rabbit) increases forward speed.
- Speed control knob can be adjusted while machine is running.

Forward Hydraulic Control

- Engage the forward hydraulic control handle to move the machine forward.
- Release the handle to stop the machine.

START-UP PROCEDURE (FIGURE 7)

Starting the Machine

1. The ON/OFF switch must be in the “OFF” position before connecting to a power source (domestic machines only).
2. Plug machine into power source.
3. Turn speed control knob to slowest position.
4. Press ON/OFF switch to the “ON” position.
5. Engage the forward hydraulic control handle to move the machine forward.

Turning Off the Machine

Press ON/OFF switch to the “OFF” position to turn off machine.

APPLICATION SETUP

VCT Tile

Never use a blade wider than the size of the tile being removed. If goods being removed still do not come up clean or machine jumps on top of goods, reduce blade size until proper blade size is found or use a smaller portion of the blade.

Pure Vinyl Rubber Tile

Goods will need to be scored down to 10-12” (25.4-30.5 cm) for proper removal. Self-scoring blades can be used with some materials. A 10” (25.4 cm) blade is recommended for this product, but determine what size blade works best.

Direct-Glued Carpet

NFE recommends using a self-scoring blade. Normally 6-14” (30.5-35.5 cm) self-scoring blades are used on direct-glued carpet, secondary-backed, unitary, double-glued, vinyl foam, and urethane foam.

Concrete

When working on concrete slab, normal blade position is bevel up for best performance, especially when cleaning adhesive. On occasion, bevel down gives better blade life. Test each job for best performance.

Gypcrete and Soft-Poured Flooring

Requires blade bevel down to create a better wearing surface.

BLADE SHARPENING

Dull blades greatly reduce cutting ability. Re-sharpen or replace as needed. In use, blades develop a back-bevel (Figure 8). When re-sharpening, blade will not be truly sharp until all back-bevel is gone.

Note: *Thinner blades are easier to sharpen, but they also break easier.*

- Always wear gloves and safety glasses.
- Grind blade using a 4" diameter disk with 120 or finer grit. Be careful not to catch disk on edge or corner of blade.
- Pass grinder along blade edge starting on one end and continuing in one direction, being careful to hold grinder at proper angle of blade. Grind until sharp.
- Using a good quality fine tooth hand file, use same procedure as above.
- Blades are sharp. Use extreme caution.
- Have plenty of sharp blades on each job so on-the-job blade sharpening is eliminated.
- It is best to sharpen dull blades on proper bench or belt grinder.

Self-Scoring Blades

It is important to keep the "wings" on a self-scoring blade sharp (Figure 9). Use a file on the wing edge. Sharpen the flat part of the blade, the same way as described above.

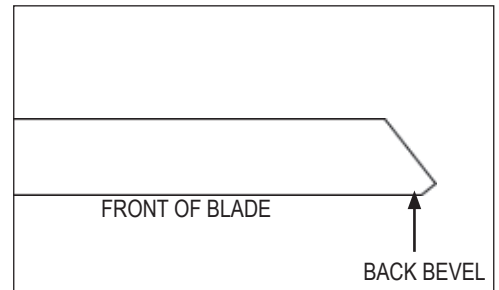

FIG. 8

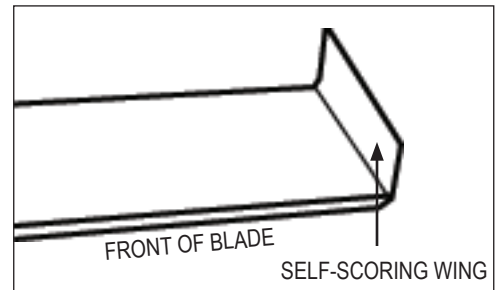

FIG. 9

Troubleshooting Guide

Problem	Cause	Solution
No forward movement.	Damaged belt.	Remove front cover plate and inspect belt.
	Damaged speed control valve.	Inspect speed control valve. Turn counter-clockwise to open valve.
Motor shuts off or won't start.		Inspect ON/OFF switch and capacitor.



WARNING: ALWAYS UNPLUG MACHINE BEFORE PERFORMING MAINTENANCE.

WHEEL REMOVAL

1. Examine back of wheels to see if debris is built up. Use a flashlight if needed.
2. Unplug machine; place block under machine between wheels.
3. Use 5/16" hex wrench to remove wheel securing screw (Figure 10).
4. Remove wheel securing cap; wheel will slide off. Watch for keyway key.
5. Remove wheel spacer. This should be inspected at regular intervals.
6. Relubricate bearing inside wheel before reassembly.



FIG. 10

ADDING OR CHANGING HYDRAULIC FLUID

- Change or add fluid when needed; check fluid level if there has been a leak, damaged or ruptured hose, or a loose fitting. Fluid should be level with bottom of tank plug hole (Figure 11).
- **To add fluid**, unscrew filler port cap from top of machine (Figure 12); add fluid through a filter or funnel with a screen to keep fluid clean.
- **To change fluid**, remove filler port cap. Remove drain plug from side of machine (Figure 13). A 2 gallon (8 liter) container will be needed to drain the fluid into. (Fluid will not be removed from hoses.) Regardless of the machine's straining system, add fluid through a filter or funnel with a screen to keep fluid clean.



FIG. 11

INSPECTION OF INTERNAL PARTS

Visual inspection of internal parts can be done without draining tank.

1. Remove two lifting bail eyebolts and the two bolts from the back of the tank.
2. Carefully lift tank 3-4" (8-10 cm).
3. Using a flashlight, inspect the drive chain, hoses, front seal on motor, and suction and pressure line on pump.
4. If service is necessary, follow procedure for tank removal.



FIG. 12

TANK REMOVAL

Removing the tank is necessary to repair the pump or replace or service internal hoses.

1. Follow procedure to change fluid in order to drain the tank.
2. Replace drain plug and filler port cap.
3. Remove two lifting bail eyebolts and the two bolts from the back of the tank.
4. Disconnect return line on back of tank, carefully lift tank 3-4" (8-10 cm) and disconnect suction line. Tank can now be removed.

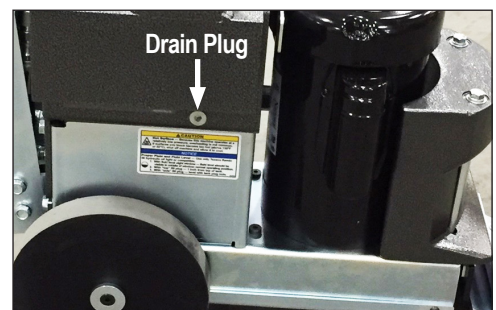

FIG. 13

Maintenance

CONTROL VALVE REPLACEMENT

1. Follow procedure to change fluid in order to drain the tank.
2. Re-place drain plug and filler port cap.
3. Disconnect valve plunger from control linkage.
4. Mark the placement of the four hoses so they can be returned to their original positions.
5. Disconnect and remove the four hoses from valve body.
6. Remove valve mounting bolts and nuts, remove valve.

Reverse these steps for installation.

SPEED CONTROL REPLACEMENT

1. Use 3/32" Allen wrench to remove metal knob.
2. Use a 1" socket to remove and replace speed control valve.
3. Re-install metal knob.

PRESSURE VALVE REPLACEMENT

This has been factory set and should not be tampered with. Use a 1" socket to remove old unit and install new.

FORWARD SWITCH REPLACEMENT

1. Disconnect machine from power source.
2. Remove two 1/4-20x1/2 hexhead bolts from handle. Use 7/16" wrench or socket.
3. Remove 1/4-20 bolt from lever.
4. Remove switch.
5. Remove two spade connectors from switch.
6. Replace switch.

POWER CORD

If power cord is damaged, it must be replaced by NFE or a qualified service center.

Parts List and Diagrams

OVERALL MACHINE

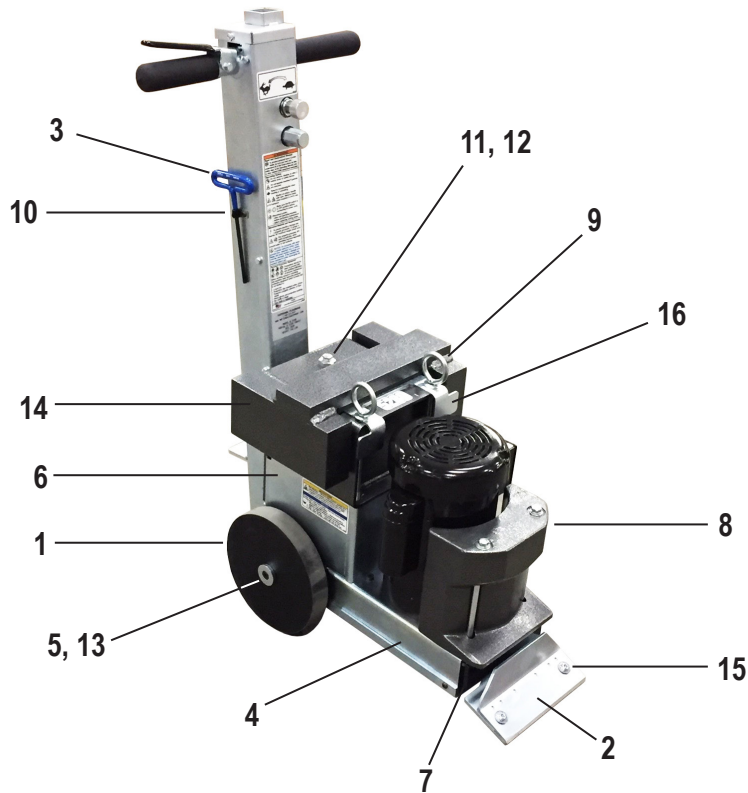

PART#	DESCRIPTION	QTY	PART#	DESCRIPTION	QTY
1	400330 WHEEL, DRIVE, LIGHT DUTY, COMPLETE	2	10	72837 CLAMP, CABLE, VINYL COATED, 5/16	1
2	5280-136 COVER, BLADE	1	11	6280-161B PLUG, VENT, FILLER CAP	1
3	5280-137W WRENCH, BLADE	1	12	6280-161D PLUG, FILLER PORT	1
4	5280-138 PLATE, BOTTOM	1	13	6280-112 CAP, WHEEL	2
5	73902 KEY, 3/16X3/16X1-3/4	2	14	5280-402-SV WEIGHT, SADDLE, SILVER VEIN	1
6	5280-153 BODY, MAIN UPPER	1	15	74649 SCREW, BUTTON HEAD CAP WITH FLANGE M10-25	2
7	5280-210 SHIELD, FRONT	1	16	405505 CRADLE, WEIGHT	1
8	401565 COUNTERWEIGHT, FRONT, CAST, 5280	1			
9	403882 EYE BOLT, 1.50 ID, 3/8-16 X 8-1/2	2			

ADDITIONAL PARTS NOT SHOWN

PART#	DESCRIPTION	QTY	PART#	DESCRIPTION	QTY
1	74631 BOLT, HEX FLANGE BOLT M6-16	3	9	73204 WASHER, LOCK, 3/8	6
2	5280-9 SPACER, WHEEL	2	10	73205 BOLT, HEX HEAD CAP 3/8-16X3/4	4
3	73315 BOLT, FLAT HEAD SOCKET 5/16-18X1	2	11	73209 BOLT, HEX HEAD CAP 3/8-16X8-1/2	2
4	74623 SCREW, BUTTON HEAD CAP M6-10	4	12	73213 SCREW, BUTTON HEAD SOCKET CAP 3/8-16X3/4	4
5	72810 CAPS, SPLICE	2	13	73263 WASHER, FLAT SAE ZINC 3/8	2
6	72811 CAPS, INSULATOR, SPLICE	2	14	401452 WASHER, FLAT, 1/2", SAE	2
7	72821 TERMINAL, RING, 16-14 GAUGE, NYLON, 10 STUD	1	15	73905 KEY, 3/16X3/16X1-1/8	2
8	73039 SCREW, CUP POINT SOCKET SET 1/4-20X3/16	3	16	73906 KEY, ALLEN SHORT ARM 3/16	1
			17	74730 GROMMET, RUBBER 5/8"	1

Parts List and Diagrams

DRIVE COMPONENTS

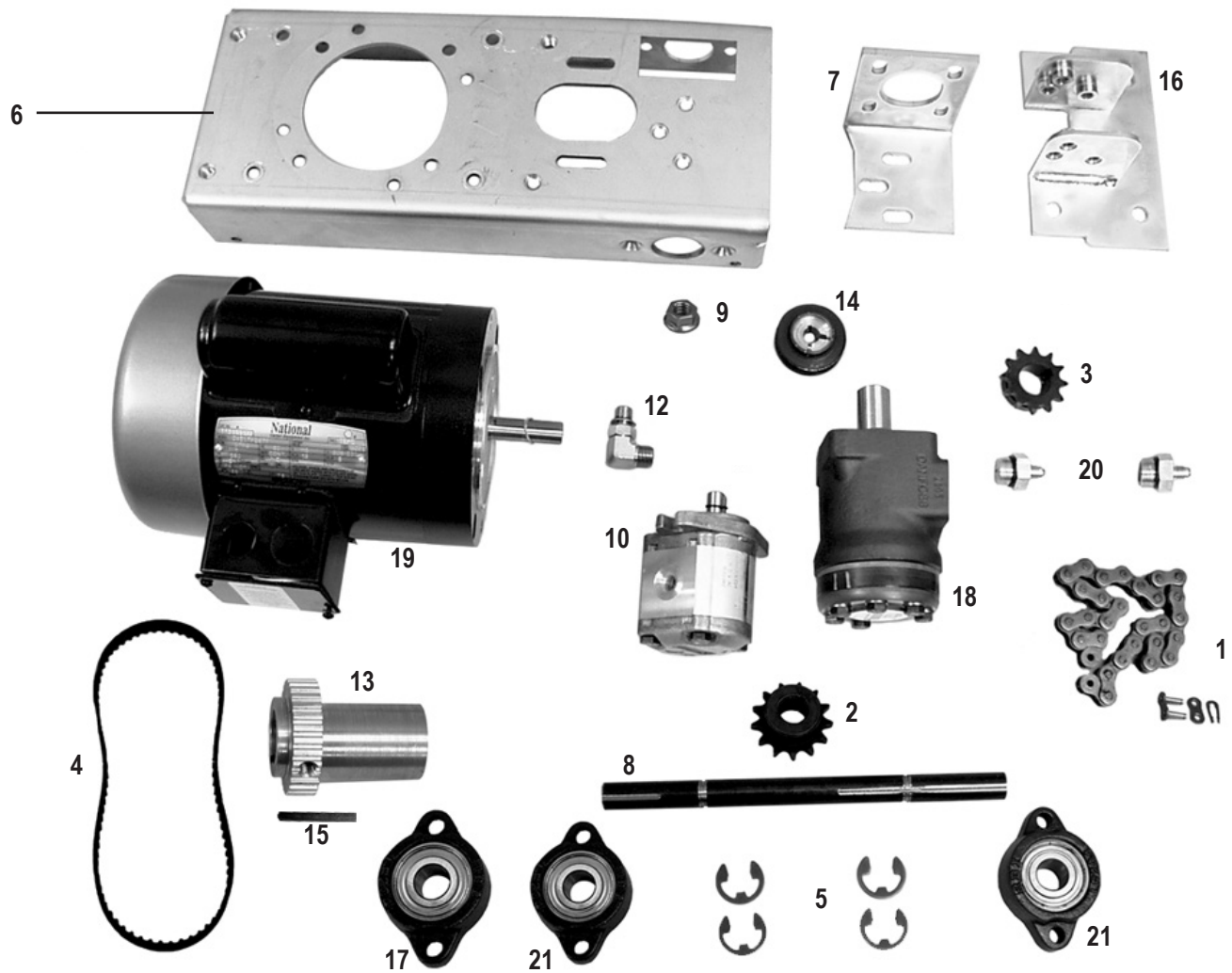

PART#	DESCRIPTION	QTY	PART#	DESCRIPTION	QTY		
1	5280-1	CHAIN, DRIVE, 40 STRAND	1	13	5280-129	ECCENTRIC	1
2	5280-2	SPROCKET, 40BS13 3/4	1	14	5280-132C	PULLEY, PUMP	1
3	5280-3	SPROCKET, MOTOR, 40BS12X1	1	15	73903	KEY, 3/16X3/16X2-1/4	1
4	5280-4	BELT, PUMP DRIVE	1	16	5280-139	BRACKET, HANDLE ADJUSTMENT	1
5	74104	RETAINER CLIP, GRINDING DISC MOUNTING POST	4	17	400324	BEARING, TURNED, 1-1/4 ID, SBLF 206-20	1
6	5280-37	PLATE, BASE	1	18	406472	MOTOR, HYDRAULIC, WD100	1
7	5280-102	BRACKET, HYDRAULIC MOTOR	1	19	72353	MOTOR, 1 HP, 116265	1
8	5280-103	AXLE, DRIVE	1	20	6280-221	CONNECTOR, HYDRAULIC MOTOR	2
9	74654	NUT, FLANGE LOCK M10	4	21	71092	BEARING, 3/4 ID	2
10	5280-113	PUMP, HYDRAULIC	1	22	72554*	CORD ASSEMBLY, MOTOR, 120 VOLT (5280-10XXXX, -23XXXX ONLY)	1
11	6280-113A*	KEY, HYDRAULIC PUMP	1	23	72554-W*	CORD ASSEMBLY, MOTOR, 220 VOLT (5280-11XXXX, -13XXXX, -20XXXX ONLY)	1
12	5280-118	FITTING, 90 DEGREE	1				

*NOT SHOWN

Parts List and Diagrams

MOTOR PARTS

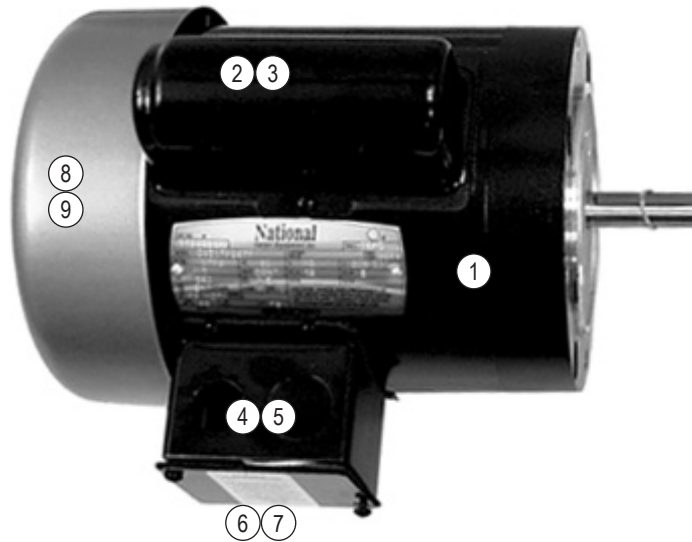

	PART#	DESCRIPTION	QTY
1	72353	MOTOR, 1 HP, 116265	1
2	5280-151	CAPACITOR, MOTOR	1
3	62182	COVER, CAPACITOR, LEESON	1
4	401698	BOX, JUNCTION, MOTOR, 3" X 3.3"	1
5	401869	GASKET, FRAME, JUNCTION BOX, 3X3.33"	1
6	401699	COVER, JUNCTION BOX, MOTOR, 3" X 3.3"	1
7	401870	GASKET, COVER, JUNCTION BOX, 3X3.33"	1
8	62181	FAN, MOTOR	1
9	400001	COVER, MOTOR FAN, TOP MOUNT SCREWS, PAINTED	1

Parts List and Diagrams

HYDRAULIC TANK

PART#	DESCRIPTION	QTY
1	5280-120 HOSE, HYDRAULIC, 3/8 X 9.25, 90F/90F	1
2	5280-162-SV HYDRAULIC TANK BODY, SILVER VEIN	1
3	6280-214 PLUG, TANK	2
4	6280-161D HYDRAULIC TANK FILLER CAP	1
5	6280-162G MAGNET, TANK (NOT SHOWN)	1
6	70601 STRAINER, TANK MOUNTED	1
7	72816 FITTING, ELBOW, 90 DEGREE, 3/8"	1
8	400177 OIL (BULK) (NOT SHOWN)	2 GAL

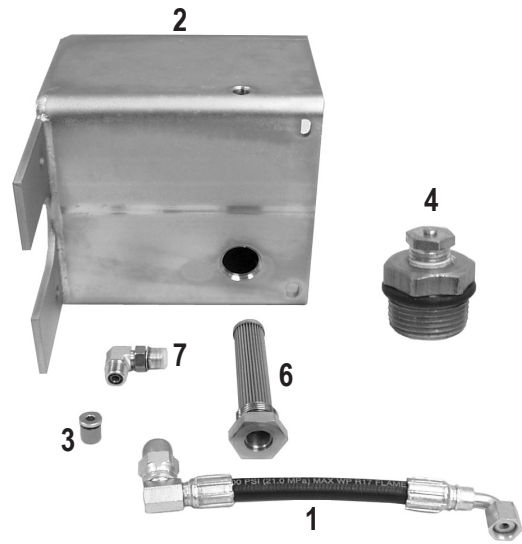

CUTTING HEAD

PART#	DESCRIPTION	QTY
1	5280-8 CUTTING HEAD	1
2	405950 ISOLATOR, VIBRATION	4
3	73211 NUT, FLANGE, SERRATED, 3/8-16	4
4	73277 SCREW, SOCKET LOW HEAD CAP, 3/8-16X5/8, BLACK OXIDE	4

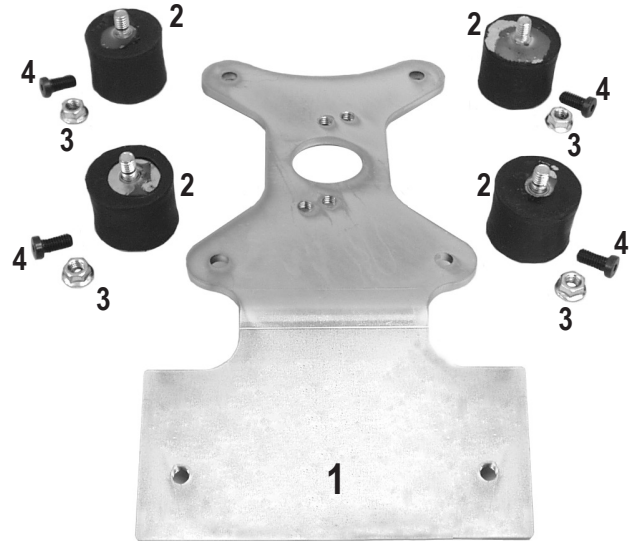

Parts List and Diagrams

BACK OF MACHINE (DOMESTIC SHOWN)

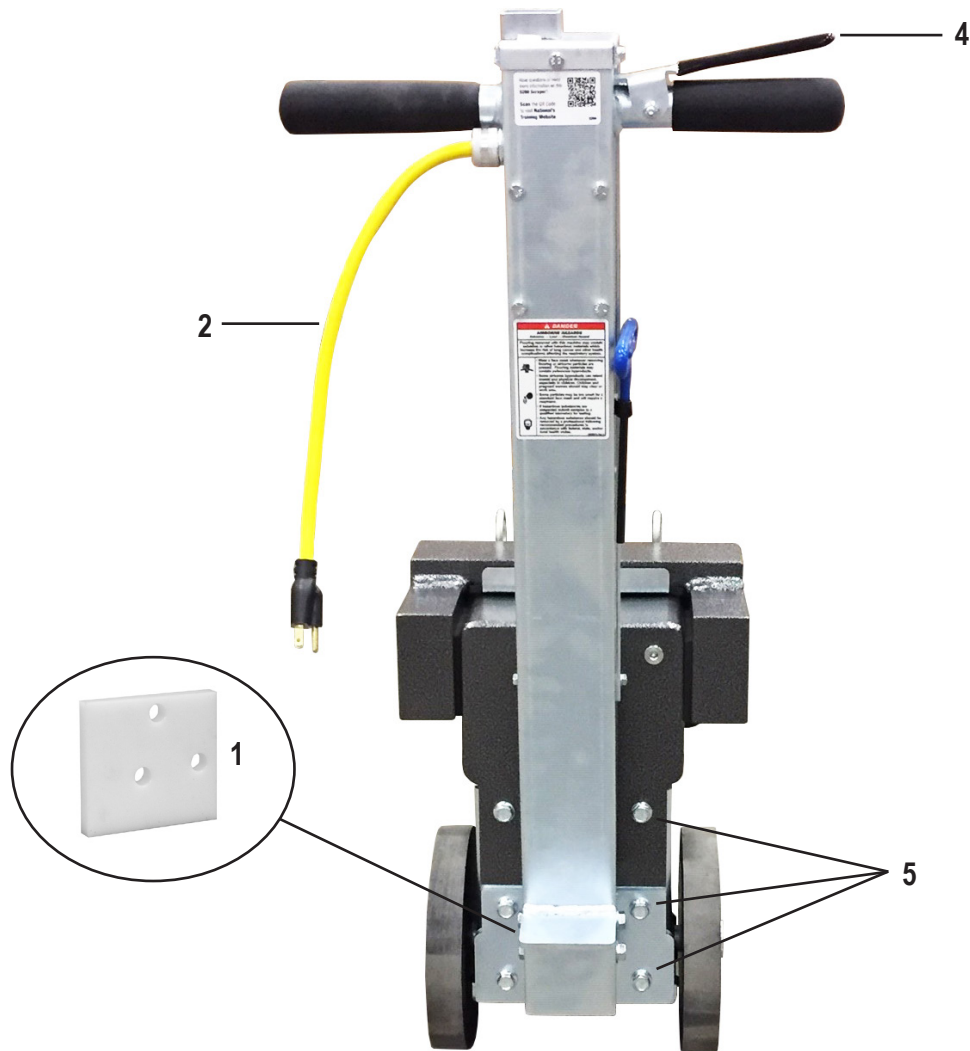

PART#	DESCRIPTION	QTY
1 5280-139C	ISOLATOR, HANDLE VIBRATION	2
2 6280-168	CORD, POWER, SJTOW, 12/3, NEMA 5-15, YELLOW, 27IN	1
3 72612*	ASSEMBLY, CORD, HANDLE, 14/3, NEMA L5-15R, 28"	1
4 5280-172A	LEVER, HANDLE	1
5 74650	BOLT, HEX FLANGE M10-25	6
6 73502*	STRAIN RELIEF, STRAIGHT 1/2 INCH, .3376-.5686	2
7 73401*	LOCKNUT, CONDUIT, 1/2"	2

*NOT SHOWN

Parts List and Diagrams

HANDLE (DOMESTIC SHOWN)

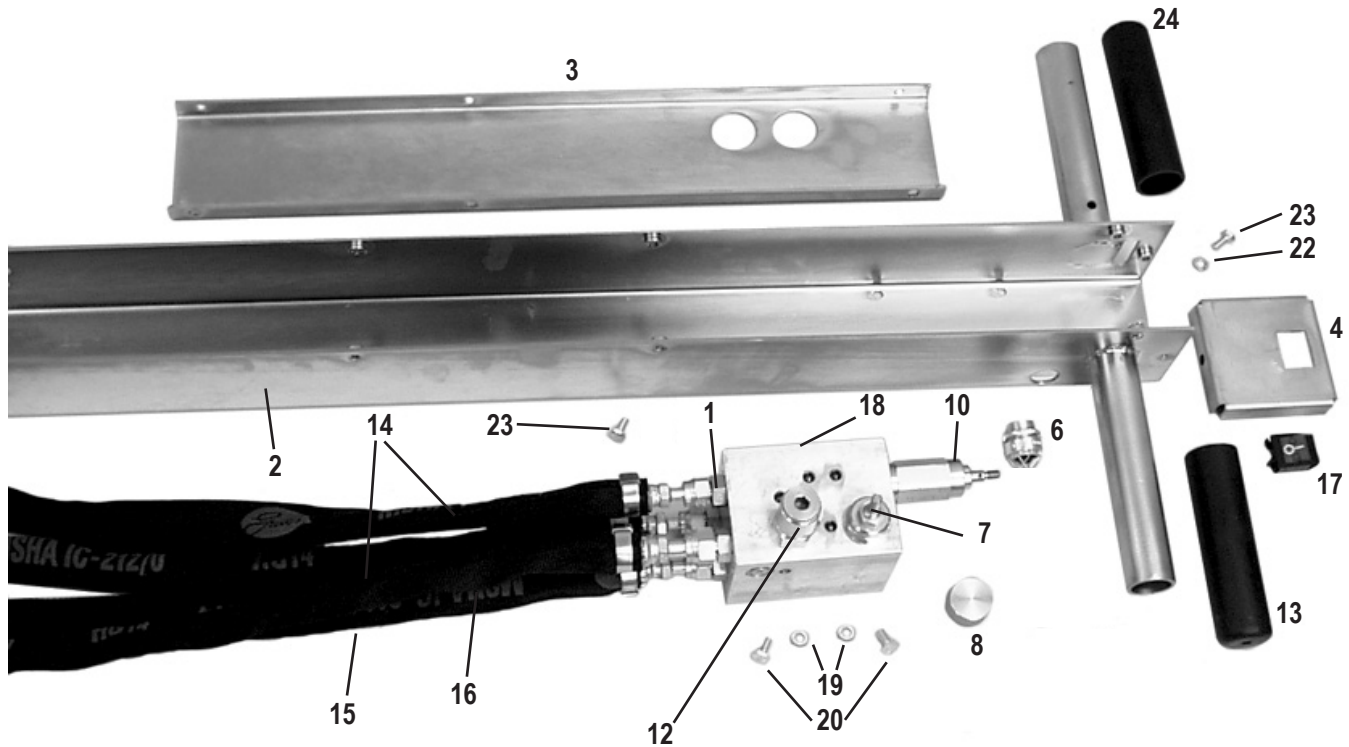

PART#	DESCRIPTION	QTY	PART#	DESCRIPTION	QTY		
1	6280-117	FITTING, PUMP	1	16	5700-76	HOSE, HYDRAULIC, 3/8 X 26, F/F	1
2	5280-167	HANDLE BODY	1	17	6280-207	SWITCH, ON-OFF	1
3	5280-167B	COVER, HANDLE BODY	1	18	6280-215	VALVE BLOCK ASSEMBLY	1
4	5280-167C	PLATE, HANDLE SWITCH	1	19	73002	WASHER, SPLIT LOCK 1/4	4
5	73401	NUT, STRAIN RELIEF, STEEL, 1/2" (NOT SHOWN)	1	20	73005	SCREW, HEX HEAD CAP 1/4-20X1/2	4
6	72804	STRAIN RELIEF, STRAIGHT, 1/2"	1	21	73032	NUT, LARGE FLANGE LOCK 1/4-20 (NOT SHOWN)	1
7	6280-208	CONTROL, SPEED	1	22	74619	WASHER, LOCK, M6	11
8	6280-208A	KNOB, SPEED CONTROL	1	23	74630	BOLT, HEX HEAD CAP M6-12 8.8	11
9	70651	PLUG, VALVE BODY (NOT SHOWN)	1	24	400306	GRIP, HAND, CUT	1
10	5280-216	CARTRIDGE, VALVE	1	25	6280-162E	PLUG, DRAIN, OIL LEVER (NOT SHOWN)	1
11	73023	BOLT, HEX HEAD CAP 1/4-20X2 (NOT SHOWN)	1	26	72812	DISCONNECT, 12-10 GAUGE, FEMALE, NYLON (NOT SHOWN)	2
12	6280-209	VALVE, PRESS CARTRIDGE	1	27	72817	CONNECTOR, CLOSED END (NOT SHOWN)	1
13	6280-170A	GRIP, HANDLE BAR	1	28	73008	NUT, NYLOCK 1/4-20 (NOT SHOWN)	1
14	6280-180	HOSE, HYDRAULIC, 1/4 X 24.25, F/F	2				
15	6280-181	HOSE, HYDRAULIC, 1/4 X 32, F/90F	1				

NOTE: SEE PAGE 19 FOR INTERNATIONAL VARIANTS.

Parts List and Diagrams

HANDLE (INTERNATIONAL ONLY)

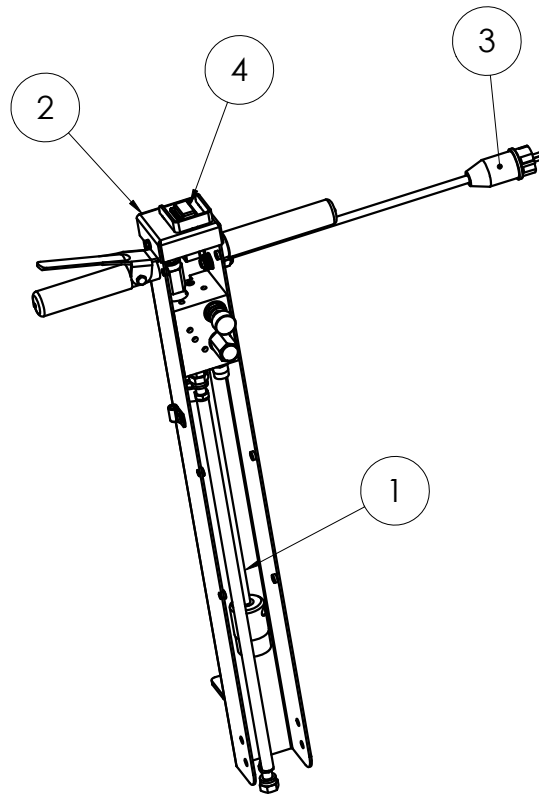

ITEM NO.	5280-11XXXX	5280-13XXXX	5280-20XXXX	DESCRIPTION	QTY.
1	404583-028	404583-028	404583-028	Assembly, Cord, Handle, 2.5mm/3, NEMA L6-15R, 28"	1
2	404313	404313	404313	Cover, Handle, Safety Switch	1
3	404172			Assembly, Cord, Power, 1.5mm/3, EU1-16P, 15in	1
		404173		Assembly, Cord, Power, 1mm/3, AUS1-16P, 15in	1
			404171	Assembly, Cord, Power, 2.5mm/3, IEC 309 110V/16A, 50ft	1
4	404180	404180		Switch, Rocker Breaker, 10A, 220-240V, UVR	1
			404144	Switch, Rocker Breaker, 18A, 90-120V, UVR	1
5*	403281	403281	403281	Nut, Keps, M4-0.7, Clear Zinc	1
6*			73401	Locknut, Conduit, 1/2"	1

*Not shown

Parts List and Diagrams

LABELS

	PART#	DESCRIPTION	QTY
1	403357-XX*	KIT, LABELS, 5280, [LANGUAGE]	1
2	402627	LABEL, PRIVATE, 1.5 X 2 (5280-23XXXX ONLY)	2
3	402628	LABEL, PRIVATE, 3.5 X 5.5 (5280-23XXXX ONLY)	2

*Suffix (-XX) denotes language: None=English; -FR=French; -NL=Dutch; -DE=German.

Parts List and Diagrams

WIRING DIAGRAM (120V DOMESTIC)

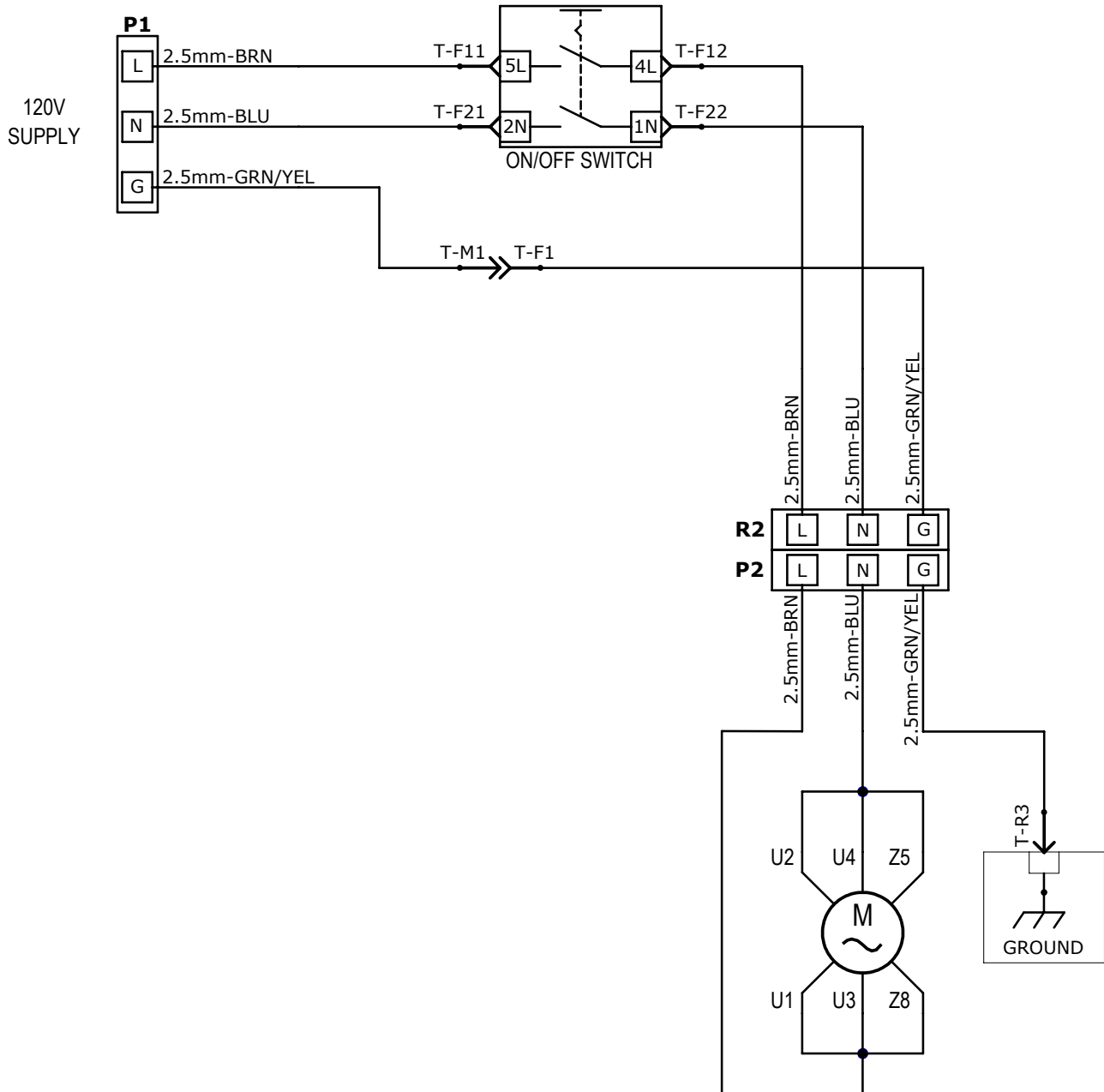

Parts List and Diagrams

WIRING DIAGRAM (230V INTERNATIONAL)

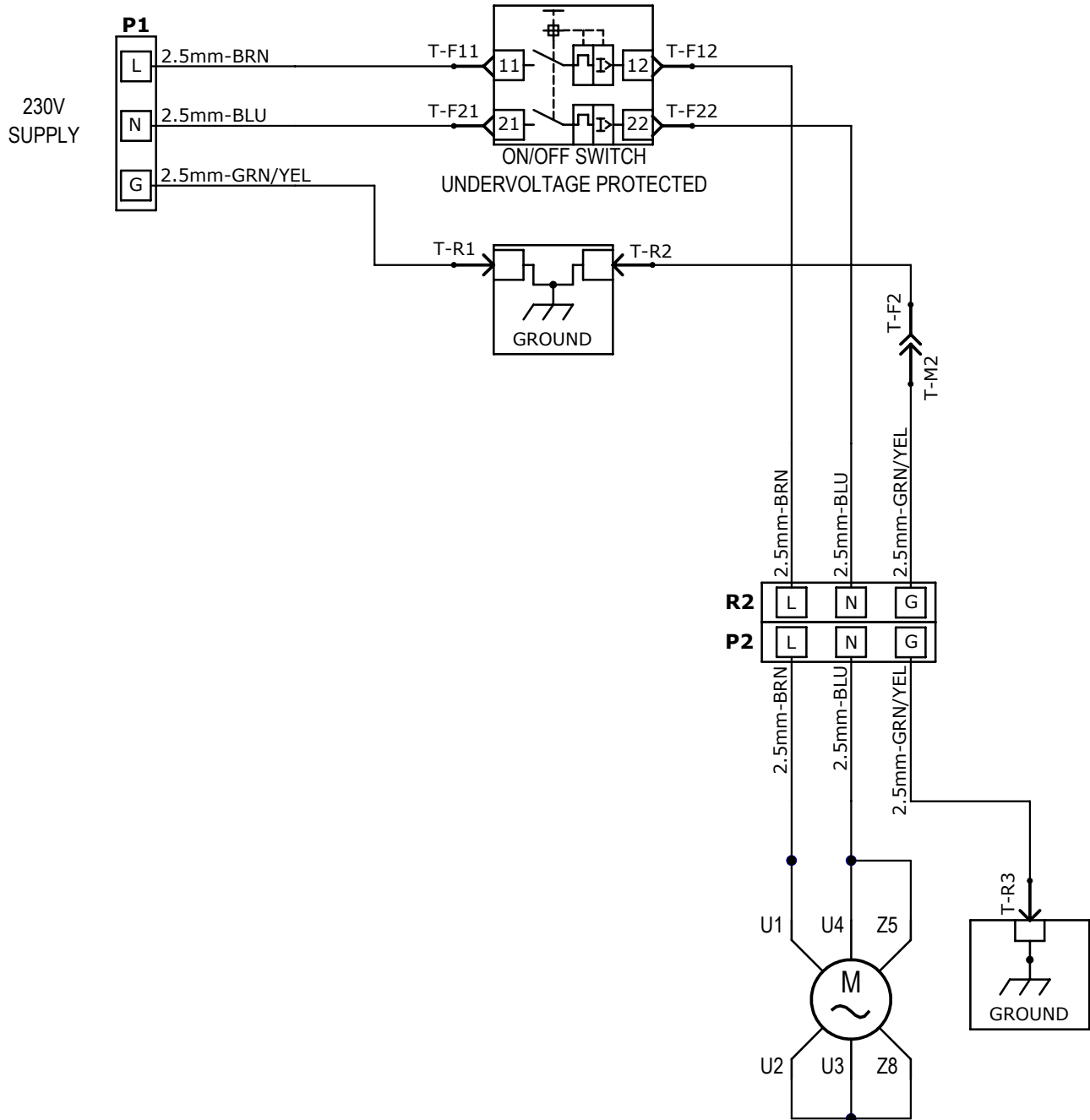

Parts List and Diagrams

WIRING DIAGRAM (100V-110V INTERNATIONAL)

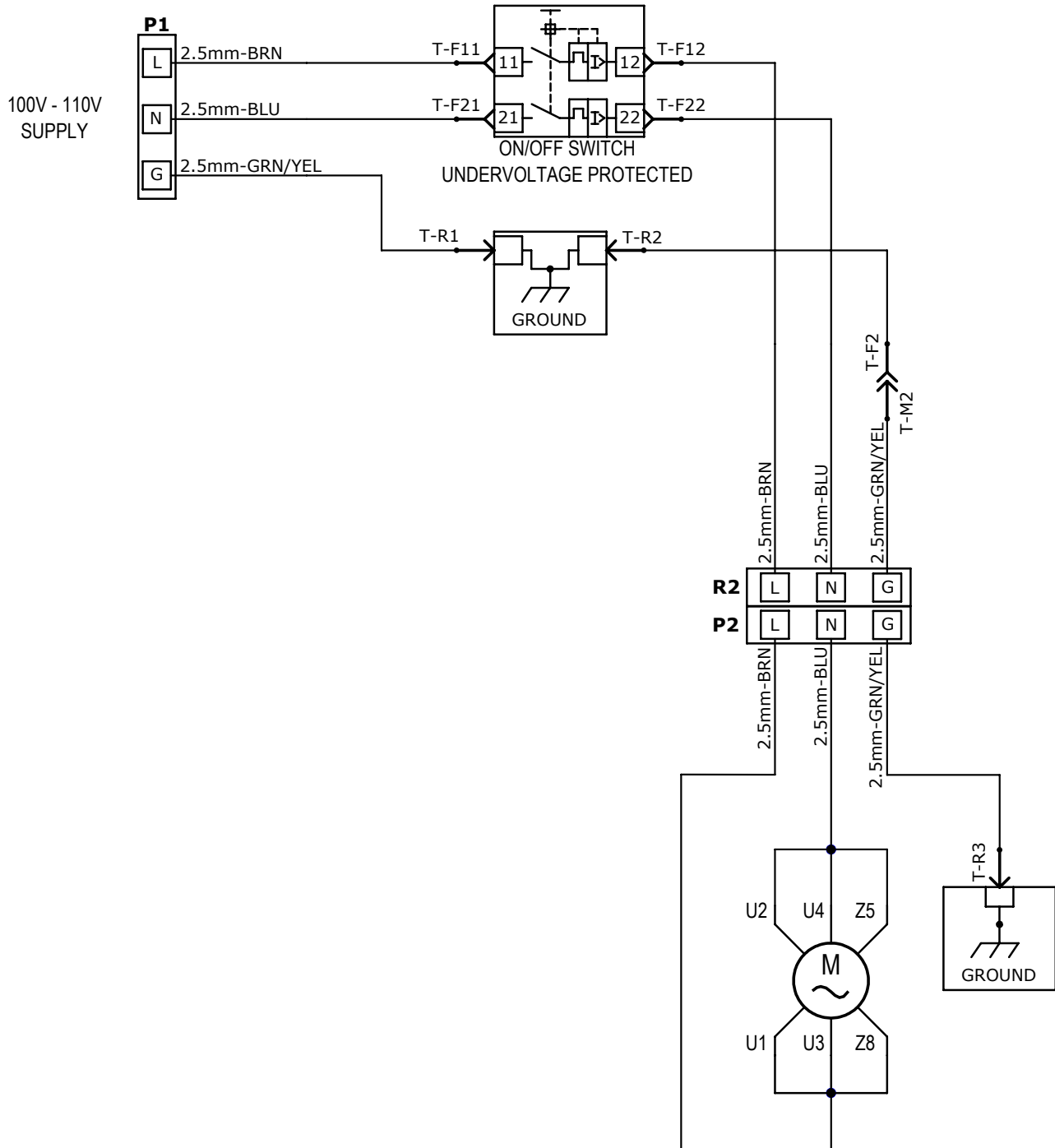

Parts List and Diagrams

HYDRAULICS

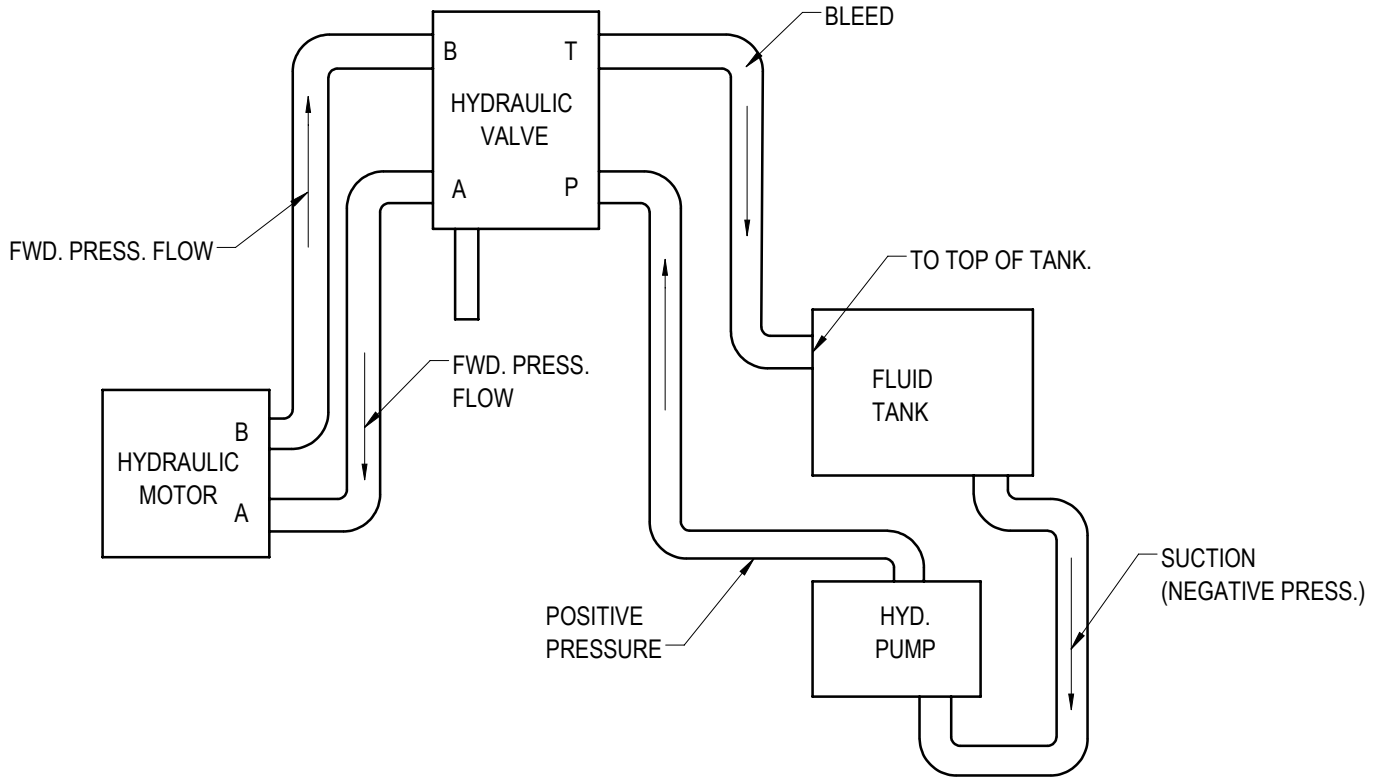

Warranty

National Flooring Equipment Inc. (referred to as "The Company") warrants that each new unit manufactured by The Company to be free from defects in materials and workmanship in normal use and service for a period of twelve (12) months from date of shipment from The Company to the end user. If shipment to end user is from a Distributor, The Company may honor warranty for up to 15 months from initial shipment from the Company if the end user can provide documentation of receipt date. Accessories or equipment furnished and installed on the product by the Company but manufactured by others, including but not limited to: engines, motors, electrical components, transmissions etc., shall carry the accessory manufacturers own warranty. Battery warranties are prorated over the warranty period. Customer is responsible for the inspection of equipment or parts upon delivery. **Freight damages are excluded from this warranty.**

The Company, at its determination of defect, will repair or replace any product or part deemed to be defective in material or workmanship within specified warranty time period. All product determinations and / or repairs will take place at The Company repair facility or at a certified warranty location designated by The Company. The Company will coordinate and be responsible for all freight expenses associated with valid warranty claims. Freight and shipping expenses associated with abuse or misuse will be back charged to the Distributor/Customer. The Company reserves the right to modify, alter or improve any part / parts without incurring any obligation to replace any part / parts previously sold without such modified, altered or improved part / parts. In no event shall the seller or manufacturer of the product be liable for special, incidental, or consequential damages, including loss of profits, whether or not caused by or resulting from the negligence of seller and / or the manufacturer of the product unless specifically provided herein. **This warranty shall not apply to any products or portions thereof which have been subjected to abuse, misuse, improper installation or operation, lack of recommended maintenance, electrical failure or abnormal conditions, and to products which have been tampered with, altered, modified, repaired, reworked by anyone not approved or authorized by the Company or used in any manner inconsistent with the provisions of the above or any instructions or specifications provided with or for the product.** Any and all unauthorized onsite warranty work conducted by unauthorized personnel or any outside person(s), is not covered by The Company unless the work has been pre-authorized by a predetermined manufacturer representative. This warranty excludes wearable parts and/or consumables.

Defective or failed material or equipment shall be held at the purchaser's premises until authorization has been granted by The Company to return or dispose of defective products. Products returned to The Company for inspection must be returned with a manufacturer authorized Return Material Authorization (RMA), and must be packaged to The Company's specifications to avoid damage during shipment. Any unauthorized return of equipment will be declined at the dock by The Company. Any non-approved items returned with approved returned items are subject to rejection and will not be credited. Credit will be issued for material found to be defective upon The Company's inspection based on prices at time of purchase.

TO OBTAIN SERVICE CONTACT NATIONAL FLOORING EQUIPMENT, INC. TOLL FREE AT 800-245-0267 FOR A REPAIR AUTHORIZATION NUMBER. COD FREIGHT RETURNS WILL NOT BE ACCEPTED. FREIGHT COLLECT SHIPMENTS WILL NOT BE ACCEPTED. WARRANTY REPAIRS MUST BE ACCOMPANIED BY DATE OF PURCHASE RECEIPT AND A RETURN/ REPAIR AUTHORIZATION NUMBER.

RETURN/REPAIR AUTHORIZATION NUMBER: _____

MACHINE SERIAL NUMBER: _____



Made in America Since 1968

9250 Xylon Avenue N • Minneapolis, MN 55445 • U.S.A.
Toll-free 800-245-0267 • Phone 763-315-5300 • Fax 800-648-7124 • Fax 763-535-8255
Web Site: www.nationalequipmentdirect.com • E-Mail: info@nationalequipment.com