

# 550 ADJUSTABLE HANDLE SCRAPER

# OPERATING & SERVICE MANUAL



Read Manual Before Operating or  
Servicing Machine

401862 Rev J



# Table of Contents

---

<b>Table of Contents</b> .....	<b>3</b>
<b>Features and Specifications</b> .....	<b>4</b>
<b>Safety</b> .....	<b>6</b>
General Rules for Safe Operation .....	6
Walk-Behind Scraper Safety Guidelines .....	7
Recommended Electrical Practices .....	8
<b>Components and Assembly</b> .....	<b>10</b>
Transport .....	10
Assembly .....	10
Application Set-Up .....	10
<b>Operation</b> .....	<b>12</b>
Wheel and Handle Adjustment .....	12
Start-Up Procedure .....	12
Preparing Blades .....	12
<b>Troubleshooting Guide</b> .....	<b>14</b>
<b>Maintenance</b> .....	<b>15</b>
Maintaining Equipment .....	15
<b>Parts List and Diagrams</b> .....	<b>16</b>
Overall Machine .....	16
Frame and Wheel Assembly .....	17
550-11 Wheel Adjustment Assembly .....	18
Cutting Head .....	19
Motor .....	20
Switch-Domestic Machines .....	21
Switch-International Machines .....	22
Counterweight .....	24
Upper Handle .....	24
Labels .....	25
Accessories .....	25
Wiring Diagrams .....	26
<b>Warranty</b> .....	<b>29</b>

# Features & Specifications

---



## FEATURES

**Adjustable Handle** - Allows the operator to adjust for comfort.

**Foot Bar** - Use of lower body strength reduces fatigue.

**Angle Adjustment** - Allows the operator to adjust the pitch of the blade from shallow to steep depending on the material being removed. This prevents gouging to the floor and sub-floor.

**Removable Weight with Lift Handle** - Enables a single person to load and/or unload machine. Removable weight is 44 lb. (20 kg).

**Cutting Head/Blade Holder** - Efficiently cuts through multiple substrate materials and increases blade longevity.

# Features & Specifications

Product Specifications							
Width	Max.Length	Height	Weight (Machine Only)	Speed	Vibration		
					X Axis	Y Axis	Z Axis
17.75" (45 cm)	32.5" (83 cm)	42.5" (108 cm) with handle 21" (53 cm) without handle	123 lb (55.8 kg)	Manual	5.5 m/s <sup>2</sup>	11.1 m/s <sup>2</sup>	11.6 m/s <sup>2</sup>

Machine Variants					
Region	Serial Number	Input Power	Amps (Full Load)	RPM	Body Panels
Domestic (North America)	550-10XXXX	120V / 60 Hz	14A	1800	Silver Vein
	550-12XXXX	120V / 60 Hz	14A	1800	Green
	550-23XXXX	120V / 60 Hz	14A	1800	Silver Vein
International	550-11XXXX	230V / 50 Hz	7A	1425	Silver Vein
	550-13XXXX	230V / 50 Hz	7A	1425	Silver Vein
	550-15XXXX	230V / 50 Hz	7A	1425	Orange
	550-20XXXX	110V / 50 Hz	13A	1425	Silver Vein
	550-29XXXX	230V / 50 Hz	7A	1425	Silver Vein

# Safety

## GENERAL RULES FOR SAFE OPERATION

Before use, anyone operating or performing maintenance on this equipment must read and understand this manual, as well as any labels packaged with or attached to the machine and its components. Read the manual carefully to learn equipment applications and limitations, as well as potential hazards associated with this type of equipment. Keep manual near machine at all times. If your manual is lost or damaged, contact National Flooring Equipment (NFE) for a replacement.

### PERSONAL

#### **Dress properly and use safety gear.**

Do not wear loose clothing; it may be caught in moving parts. Anyone in the work area must wear safety goggles or glasses and hearing protection. Wear a dust mask for dusty operations. Hard hats, face shields, safety shoes, etc. should be worn when specified or necessary.

#### **Maintain control; stay alert.**

Keep proper footing and balance, and maintain a firm grip. Observe surroundings at all times. Do not use when tired, distracted, or under the influence of drugs, alcohol, or any medication that may cause decreased control.

#### **Keep hands away from all moving parts and tooling.**

Wear gloves when changing tooling. Remove tooling when machine is not in use and/or lower cutting head to the floor.

#### **Do not force equipment.**

Equipment will perform best at the rate for which it was designed. Excessive force only causes operator fatigue, increased wear, and reduced control.

### ENVIRONMENT

#### **Avoid use in dangerous environments.**

Do not use in rain, damp or wet locations, or in the presence of explosive atmospheres (gaseous fumes, dust, or flammable materials). Remove materials or debris that may be ignited by sparks. Keep work area tidy and well-lit - a cluttered or dark work area may lead to accidents. Extreme heat or cold may affect performance.

#### **Protect others in the work area and be aware of surroundings.**

Provide barriers or shields as needed to protect others from debris and machine operation. Children and other bystanders should be kept at a safe distance from the work area to avoid distracting the operator and/or coming into contact with the machine. Operator should be aware of who is around them and their proximity. Support personnel should never stand next to, in front of, or behind the machine while the machine is running. Operator should look behind them before backing up.

#### **Do not come within 3 ft. of the machine's perimeter during operation.**

#### **Guard against electric shock.**

Ensure that machine is connected to a properly grounded outlet. Prevent bodily contact with grounded surfaces, e.g. pipes, radiators, ranges, and refrigerators. When scoring or making cuts,

always check the work area for hidden wires or pipes.

#### **Begin maintenance work only when the machine is shut down, unplugged, and cooled down.**

#### **Use proper cleaning agents.**

Ensure that all cleaning rags are fiber-free; do not use any aggressive cleaning products.

#### **Schedule regular maintenance check-ups.**

Ensure machine is properly cleaned and serviced. Remove all traces of oil, combustible fuel, or cleaning fluids from the machine and its connections and fittings. Retighten all loose fittings found during maintenance and repair work. Loose or damaged parts should be replaced immediately; use only NFE parts.

#### **Do not weld or flame-cut on the machine during repairs, or make changes to machine without authorization from NFE.**

### EQUIPMENT

#### **Use proper parts and accessories.**

Only use NFE-approved or recommended parts and accessories. Using any that are not recommended may be hazardous.

#### **Ensure accessories are properly installed and maintained.**

Do not permanently remove a guard or other safety device when installing an accessory or attachment.

#### **Inspect for damaged parts.**

Check for misalignment, binding of moving parts, loose fasteners, improper mounting, broken parts, and any other conditions that may affect operation. If abnormal noise or vibration occurs, turn the machine off immediately. Do not use damaged equipment until repaired. Do not use if power switch does not turn machine on and off. For all repairs, insist on only identical NFE replacement parts.

#### **Maintain equipment and labels.**

Keep handles dry, clean, and free from oil and grease. Keep cutting edges sharp and clean. Follow instructions for lubricating and changing accessories. Motor and switches should be completely enclosed at all times with no exposed wiring. Inspect cord regularly. Labels carry important information; if unreadable or missing, contact NFE for a free replacement.

#### **Avoid accidental starting; store idle equipment.**

When not in use, ensure that the machine is unplugged; do not turn on before plugging in. Store in a dry, secured place. Remove tooling when storing, and keep away from children.

## WALK-BEHIND SCRAPER SAFETY GUIDELINES

Before use, anyone operating this equipment must read and understand these safety instructions.

### SCRAPING

#### **Beware of hidden obtrusions.**

Watch out for hidden dangers and protrusions in flooring. Do not use on largely uneven surfaces.

#### **Observe location of electrical supplies and extension cords.**

Do not allow cutting heads to come into contact with any electrical supply or extension cord.

#### **Use correct tooling and accessories.**

Provide barriers or shields as needed to protect others from debris. After mounting tooling, check for proper alignment.

#### **Use for correct applications.**

Do not force equipment to do heavier duty work than it was made for.

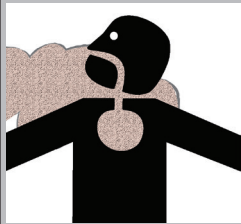

**WARNING:** GRINDING/CUTTING/DRILLING OF MASONRY, CONCRETE, METAL AND OTHER MATERIALS CAN GENERATE DUST, MISTS AND FUMES CONTAINING CHEMICALS KNOWN TO CAUSE SERIOUS FATAL INJURY OR ILLNESS, SUCH AS RESPIRATORY DISEASE, CANCER, BIRTH DEFECTS OR OTHER REPRODUCTIVE HARM. IF YOU ARE UNFAMILIAR WITH THE RISKS ASSOCIATED WITH THE PARTICULAR MATERIAL BEING CUT, REVIEW THE MATERIAL SAFETY DATA SHEET AND/OR CONSULT YOU EMPLOYER, THE MATERIAL MANUFACTURER/SUPPLIER, GOVERNMENTAL AGENCIES SUCH AS OSHA AND NIOSH AND OTHER AUTHORITIES ON HAZARDOUS MATERIALS. CALIFORNIA AND SOME OTHER AUTHORITIES, FOR INSTANCE, HAVE PUBLISHED LISTS OF SUBSTANCES KNOWN TO CAUSE CANCER, REPRODUCTIVE TOXICITY, OR OTHER HARMFUL EFFECTS. CONTROL DUST, MIST AND FUMES AT THE SOURCE WHERE POSSIBLE. IN THIS REGARD USE GOOD WORK PRACTICES AND FOLLOW THE RECOMMENDATIONS OF THE MANUFACTURER/SUPPLIER, OSHA/NIOSH, AND OCCUPATIONAL AND TRADE ASSOCIATIONS. WHEN THE HAZARDS FROM INHALATION OF DUST, MISTS AND FUMES CANNOT BE ELIMINATED, THE OPERATOR AND ANY BYSTANDERS SHOULD ALWAYS WEAR A RESPIRATOR APPROVED BY OSHA/MSHA FOR THE MATERIAL BEING CUT.

# Safety

## RECOMMENDED ELECTRICAL PRACTICES



**CAUTION:** ALWAYS FOLLOW APPLICABLE ELECTRICAL CODES, STANDARDS AND/OR REGULATIONS. CONSULT YOUR LOCAL ELECTRICAL AUTHORITY OR A LICENSED ELECTRICIAN BEFORE ATTEMPTING TO MODIFY AN ELECTRICAL INSTALLATION. ENSURE THAT CIRCUIT AND GROUND FAULT PROTECTION DEVICES AND ALL OTHER ELECTRICAL SAFETY EQUIPMENT ARE FUNCTIONING PROPERLY.

### POWER CORD SIZING

All cords should be sized appropriately to reduce the risk of damage, fire or reduced performance. Reference the tables in this section for recommended cord sizes.

### TABLE INFORMATION

These tables are based on a <10% voltage loss, data from the U.S. National Electrical Code Tables 400.5(A) & 400.5(B) and typical resistances for standard copper wire.

### HOW TO USE THIS TABLE

1. Determine your supply voltage.
2. Determine the total length of your cord including any extension cords.
3. Determine the maximum amp draw for your machine.
4. Trace your voltage across the top of the table to the first length that is greater than or equal to your cord length.
5. Follow the column down to the first row that contains a maximum amp draw greater than or equal to yours.
6. This cell contains the minimum recommended wire size for your application.

### EXAMPLE

**Application:** Max Amps = 13A, Length = 60ft, Voltage = 120V

**Solution:** 60ft is between the 50ft and 75ft columns, so the larger of the two columns is chosen. Likewise, 13A is between the 12A and 14A rows, so the larger of the two rows is chosen. 12 AWG (4mm<sup>2</sup>) is the minimum recommended wire size for this example.

Single-Phase Equipment					
Max Length	100V Supply	20ft (6m)	40ft (12m)	60ft (20m)	80ft (24m)
	120V Supply	25ft (7.5m)	50ft (15m)	75ft (25m)	100ft (30m)
	230V Supply	50ft (15m)	100ft (30m)	150ft (45m)	200ft (60m)
Max Amps		Minimum Wire Size			
8	16 AWG (1.5mm <sup>2</sup> )	16 AWG (1.5mm <sup>2</sup> )	14 AWG (2.5mm <sup>2</sup> )	12 AWG (4mm <sup>2</sup> )	10 AWG (6mm <sup>2</sup> )
10	16 AWG (1.5mm <sup>2</sup> )	14 AWG (2.5mm <sup>2</sup> )	12 AWG (4mm <sup>2</sup> )	10 AWG (6mm <sup>2</sup> )	8 AWG (16mm <sup>2</sup> )
12	14 AWG (2.5mm <sup>2</sup> )	14 AWG (2.5mm <sup>2</sup> )	12 AWG (4mm <sup>2</sup> )	10 AWG (6mm <sup>2</sup> )	8 AWG (16mm <sup>2</sup> )
14	14 AWG (2.5mm <sup>2</sup> )	12 AWG (4mm <sup>2</sup> )	12 AWG (4mm <sup>2</sup> )	10 AWG (6mm <sup>2</sup> )	8 AWG (16mm <sup>2</sup> )
16	12 AWG (4mm <sup>2</sup> )	12 AWG (4mm <sup>2</sup> )	10 AWG (6mm <sup>2</sup> )	10 AWG (6mm <sup>2</sup> )	8 AWG (16mm <sup>2</sup> )
18	12 AWG (4mm <sup>2</sup> )	10 AWG (6mm <sup>2</sup> )	10 AWG (6mm <sup>2</sup> )	8 AWG (16mm <sup>2</sup> )	8 AWG (16mm <sup>2</sup> )



## RECOMMENDED ELECTRICAL PRACTICES—CONTINUED

Single-Phase Equipment					
Max Length	100V Supply	20ft (6m)	40ft (12m)	60ft (20m)	80ft (25m)
	120V Supply	25ft (7.5m)	50ft (15m)	75ft (25m)	100ft (30m)
	230V Supply	50ft (15m)	100ft (30m)	150ft (45m)	200ft (60m)
Max Amps		Minimum Wire Size			
8	16 AWG (1.5mm <sup>2</sup> )	16 AWG (1.5mm <sup>2</sup> )	14 AWG (2.5mm <sup>2</sup> )	12 AWG (4mm <sup>2</sup> )	12 AWG (4mm <sup>2</sup> )
10	16 AWG (1.5mm <sup>2</sup> )	14 AWG (2.5mm <sup>2</sup> )	12 AWG (4mm <sup>2</sup> )	12 AWG (4mm <sup>2</sup> )	12 AWG (4mm <sup>2</sup> )
12	14 AWG (2.5mm <sup>2</sup> )	14 AWG (2.5mm <sup>2</sup> )	12 AWG (4mm <sup>2</sup> )	10 AWG (6mm <sup>2</sup> )	10 AWG (6mm <sup>2</sup> )
14	14 AWG (2.5mm <sup>2</sup> )	12 AWG (4mm <sup>2</sup> )	12 AWG (4mm <sup>2</sup> )	10 AWG (6mm <sup>2</sup> )	10 AWG (6mm <sup>2</sup> )
16	12 AWG (4mm <sup>2</sup> )	12 AWG (4mm <sup>2</sup> )	10 AWG (6mm <sup>2</sup> )	10 AWG (6mm <sup>2</sup> )	10 AWG (6mm <sup>2</sup> )
18	12 AWG (4mm <sup>2</sup> )	12 AWG (4mm <sup>2</sup> )	10 AWG (6mm <sup>2</sup> )	8 AWG (10mm <sup>2</sup> )	8 AWG (10mm <sup>2</sup> )
20	12 AWG (4mm <sup>2</sup> )	12 AWG (4mm <sup>2</sup> )	10 AWG (6mm <sup>2</sup> )	8 AWG (10mm <sup>2</sup> )	8 AWG (10mm <sup>2</sup> )
25	12 AWG (4mm <sup>2</sup> )	10 AWG (6mm <sup>2</sup> )	8 AWG (10mm <sup>2</sup> )	8 AWG (10mm <sup>2</sup> )	8 AWG (10mm <sup>2</sup> )
30	10 AWG (6mm <sup>2</sup> )	10 AWG (6mm <sup>2</sup> )	8 AWG (10mm <sup>2</sup> )	6 AWG (16mm <sup>2</sup> )	6 AWG (16mm <sup>2</sup> )

Single-Phase Equipment					
Max Length	100V Supply	100ft (30m)	120ft (35m)	140ft (40m)	160ft (48.5m)
	120V Supply	125ft (40m)	150ft (45m)	175ft (50m)	200ft (61m)
	230V Supply	250ft (75m)	300ft (90m)	350ft (105m)	400ft (122m)
Max Amps		Minimum Wire Size			
8	12 AWG (4mm <sup>2</sup> )	10 AWG (6mm <sup>2</sup> )	10 AWG (6mm <sup>2</sup> )	10 AWG (6mm <sup>2</sup> )	10 AWG (6mm <sup>2</sup> )
10	10 AWG (6mm <sup>2</sup> )	10 AWG (6mm <sup>2</sup> )	8 AWG (10mm <sup>2</sup> )	8 AWG (10mm <sup>2</sup> )	8 AWG (10mm <sup>2</sup> )
12	10 AWG (6mm <sup>2</sup> )	8 AWG (10mm <sup>2</sup> )	8 AWG (10mm <sup>2</sup> )	8 AWG (10mm <sup>2</sup> )	8 AWG (10mm <sup>2</sup> )
14	8 AWG (10mm <sup>2</sup> )	8 AWG (10mm <sup>2</sup> )	8 AWG (10mm <sup>2</sup> )	6 AWG (16mm <sup>2</sup> )	6 AWG (16mm <sup>2</sup> )
16	8 AWG (10mm <sup>2</sup> )	8 AWG (10mm <sup>2</sup> )	6 AWG (16mm <sup>2</sup> )	6 AWG (16mm <sup>2</sup> )	6 AWG (16mm <sup>2</sup> )
18	8 AWG (10mm <sup>2</sup> )	8 AWG (10mm <sup>2</sup> )	6 AWG (16mm <sup>2</sup> )	6 AWG (16mm <sup>2</sup> )	6 AWG (16mm <sup>2</sup> )
20	8 AWG (10mm <sup>2</sup> )	6 AWG (16mm <sup>2</sup> )	6 AWG (16mm <sup>2</sup> )	6 AWG (16mm <sup>2</sup> )	6 AWG (16mm <sup>2</sup> )
25	6 AWG (16mm <sup>2</sup> )	6 AWG (16mm <sup>2</sup> )	4 AWG (25mm <sup>2</sup> )	4 AWG (25mm <sup>2</sup> )	4 AWG (25mm <sup>2</sup> )
30	6 AWG (16mm <sup>2</sup> )	4 AWG (25mm <sup>2</sup> )	4 AWG (25mm <sup>2</sup> )	4 AWG (25mm <sup>2</sup> )	4 AWG (25mm <sup>2</sup> )

# Components and Assembly

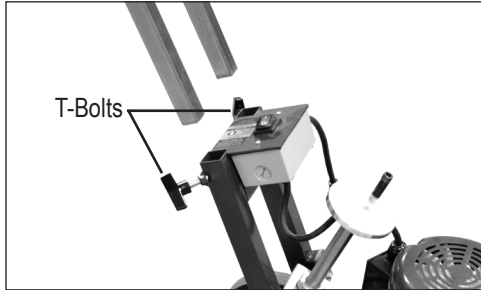

FIG. 1



FIG. 2

## TRANSPORT

Always remove counterweight and blades before loading or unloading. Machine breaks down for easy transportation:

- Remove handle (Figure 1).
- Lower handle and/or wheel angle.



**WARNING:** KEEP HANDS AND FEET OUT FROM UNDER THE MACHINE.



**CAUTION:** LOOSEN T-BOLTS BEFORE TRYING TO REMOVE THE HANDLE.

## ASSEMBLY

This machine comes disassembled. To assemble, complete the following:

1. Loosen both T-bolts on the handle frame.
2. Insert handle into handle frame (Figure 1) and adjust to the desired height.
3. Retighten T-bolts.

## APPLICATION SET-UP

### VCT TILE

Never use a blade wider than the size of the tile being removed (Figure 2). If materials being removed still do not come up clean or machine jumps on top of materials, reduce blade size or use a smaller portion of the blade.

### PURE VINYL RUBBER TILE

Materials will need to be scored down to 10-12" (25.4-30.5 cm) for proper removal. Self-scoring blades can be used with some materials. A 10" blade is recommended for this application.

### DIRECT-GLUED CARPET

NFE recommends using a self-scoring blade. Normally 6-14" (15.2-35.6 cm) self-scoring blades are used on direct-glued carpet, secondary-backed, unitary, double-glued, vinyl foam, and urethane foam.

### CERAMIC

Requires angle shank holder and carbide-tipped angle shank. Ceramic over a wood sub-floor requires a low angle so the blade is flat to the floor. Ceramic over hard sub-floor such as concrete, requires an increased angle. Experiment with the angle to see which works the best. Clear debris from area as it is removed.

### WOOD SUB-FLOOR

When working over plywood sub-flooring, try to run machine in a 45° angle to the grain in the wood. Blade in most cases should be bevel down. On solid wood floors, like plank, run 45° to the plank parallel to grain. Removing the front counter weight will help on all soft surfaces. Rounding off the corners of the blade will help from digging into the floor.

# Components and Assembly

## CONCRETE

When working on concrete slab, a normal blade position is bevel up for best performance, especially when cleaning adhesive. On occasion, bevel down gives better blade life. Test each job for best performance.

## GYPCRETE AND SOFT-POURED FLOORING

Requires blade bevel down to create a better wearing surface.

## GLUED HARDWOOD FLOORING

A carbide-tipped angle shank or a 6" (15.2 cm) blade is recommended. For proper removal of hardwood flooring (parkay laminated, plank laminated, plank solid) flooring must be scored across the grain or plank direction. This is done by using a circular saw set at a depth of 100% of the thickness of the board, just missing the subfloor surface when on concrete (Figure 3). A chalk line for scoring lines can be used across the floor the width of the blade. A ripping guide attached to the saw can be used to eliminate chalk line marks. Open an area large enough to fit machine or start from a doorway. It is important to keep all debris cleaned up for maximum performance of machine. True parkay flooring will come up in small pieces so scoring is not necessary.

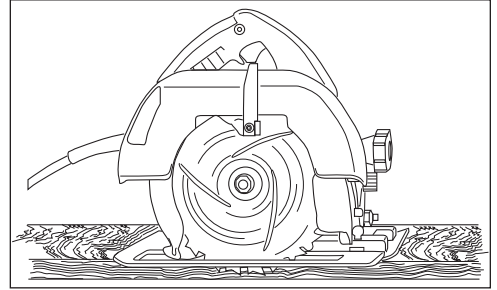

FIG. 3

# Operation

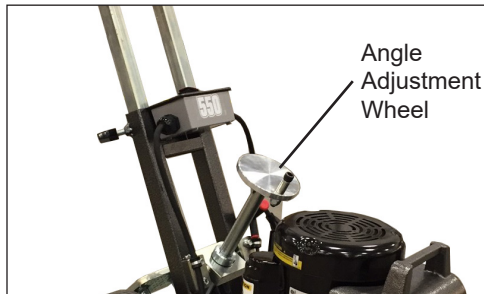

FIG. 4

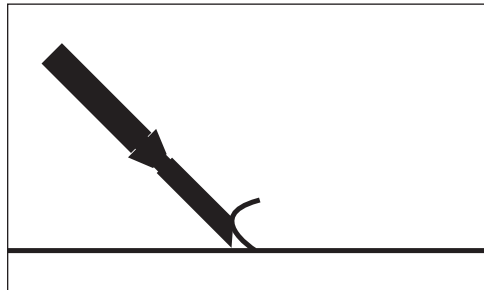

FIG. 5

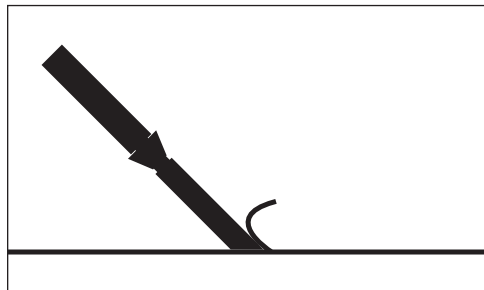

FIG. 6

## WHEEL AND HANDLE ADJUSTMENT

Adjusting the wheel angle will change the blade angle to the floor. Rotate handle clockwise to raise wheels and counterclockwise to lower wheels to the desired blade angle (Figure 4).

- A steep wheel angle is recommended on hard tear-outs, e.g. tile over concrete.
- A low wheel angle is recommended for vinyl, VCT, or carpet removal over plywood floors, soft sub-floors, plywood, luan, particleboard, or wafer board.

**Note:** Experiment with the angle to see what works the best for the application.



**CAUTION:** ONLY MAKE ADJUSTMENTS WHEN ON A FLAT SURFACE AND MACHINE IS TURNED OFF.

After the proper wheel adjustment is achieved, adjust the handle. No matter what the wheel angle is set at, the handle should be adjusted to the “belt-line” of the operator or to what the operator is comfortable with.

## START-UP PROCEDURE

### STARTING THE MACHINE

1. The ON/OFF switch must be in the “OFF” position before connecting to a power source (domestic machines only).
2. Plug machine into power source.
3. Press ON/OFF switch to the “ON” position.

### TURNING OFF THE MACHINE

Press ON/OFF switch to the “OFF” position to turn off machine.

## PREPARING BLADES



**CAUTION:** BLADES ARE SHARP, WEAR GLOVES AND USE EXTREME CAUTION WHILE HANDLING.



**CAUTION:** NEVER CHANGE CUTTING HEAD OR SERVICE BLADES WHILE MACHINE IS RUNNING.

### SETTING

- Proper blade size and placement will affect performance, depending on the material and sub-floor type.
- For difficult materials, use smaller blades.
- Start with a narrow blade, then increase blade size to optimize cutting pass. Narrower blades work easier than wider blades and usually clean the floor better.
- Normally, bevel up is for concrete (Figure 5); bevel down is for wood or softer substrates, e.g. Gypcrete (Figure 6).
- Keep blades sharp. Dull blades greatly affect the performance of the machine and reduce cutting ability. Sharpen or replace blades as needed.
- Keep work area clean and clear of debris. After removing a portion of material, move it out of the way.

# Operation

- For wood or wood-like floors, pound down or remove any nails or metal obstructions to avoid blade damage.
- Blades can be offset in the cutting head for easier access to toe kicks or for removal along the wall (Figure 7).
- Sheet vinyl, solid vinyl, rubber tile, urethane, or PVC sheet roofing will need to be scored for best removal results. Score flooring to the width of the blade.
- Self-scoring blades are available in a number of sizes; these blades eliminate the need for pre-scoring material. Depending upon the type of material being removed and the sharpness of the blade and scoring wings, the self-scoring blades may make it harder to control the machine. Keep scoring wings sharp at all times.

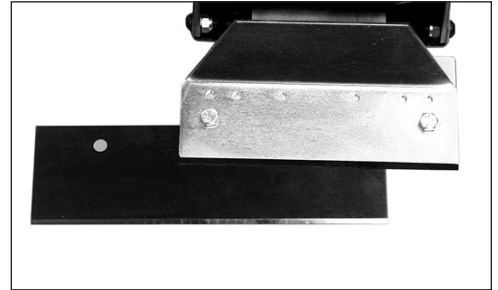

FIG. 7

## CHANGING

1. Block up the front of the machine using a flat piece of wood or something similar.
2. Use a wrench with enough extension to keep hand safely away from the blade to loosen the blade cover bolts. It is not necessary to remove them completely.
3. Place blade between the cutting head and blade clamp. Push blade back until it contacts the recess in the cutting head; tighten the blade holding bolts. If the blade is wider than the cutting head, center the blade to the head. If the blade is smaller than the cutting head, the blade should be mounted in the center of the cutting head during the first pass. After the first pass is made, the blade can be offset in the head to allow the wheels to keep even contact with the floor and provide easy access to the wall.
4. Tighten the bolts.

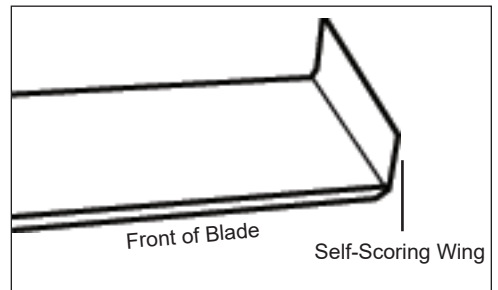

FIG. 8

## SHARPENING

Always check for blade sharpness before using. Over time, the used blades will develop a back bevel. While sharpening, blades will not recover entirely until the back bevel is completely leveled out.

**Note:** *Thinner blades are easier to sharpen, but they also break easier.*

- Grind blade using a 4" (10 cm) diameter disk with 120 or finer grit. Be careful not to catch disk on the edge or corner of the blade.
- Pass grinder along blade edge starting on one end and continuing in one direction being careful to hold grinder at proper angle for the blade. Grind until sharp.
- While using a high quality fine tooth hand file, follow the same procedure as above.
- Have plenty of sharp blades on each job so that on-the-job blade sharpening is eliminated.
- It is best to sharpen blades on a proper bench or belt grinder in the shop.

**Self-Scoring Blade Sharpening (Figure 8):** It is important to keep the "wings" on these self-scoring blades sharp. Use a file on the edge; sharpen the flat part of the blade as described above.

**Carbide-Tipped Blade Sharpening:** To sharpen carbide-tipped blades, a carbide grinding wheel is necessary (e.g. silicon carbide or green wheel).

# Troubleshooting Guide

Problem	Cause	Solution
No power	Insufficient power	Inspect electrical cord for damage.
	Switch/Circuit	Check if circuit breaker and/or switch are tripped.
Motor noise	Fan guard is malfunctioning.	Ensure fan guard is not bent.
Machine is hard to handle.	Machine is too heavy.	Remove counterweight.
	Blade is too large.	Change to a smaller blade size.
	Blade is too dull.	Sharpen blade.
Blown fuses or circuit breakers	Wrong extension cord	Use appropriate extension cord (see Safety).
	Poor quality outlet	Move to a different outlet or better circuit.
Rattling	Loose fasteners	Check for loose nuts and bolts and re-tighten.
	Worn out isolators	Replace isolators.
Difficulty inserting shank	Shank holder is too tight.	Remove paint from shaft of the shank with sandpaper, emery cloth, or a solvent.

## MAINTAINING EQUIPMENT



**WARNING:** ALWAYS UNPLUG MACHINE BEFORE MAINTAINING. NEVER DISASSEMBLE THE TOOL OR TRY TO DO ANY REWIRING ON THE TOOL'S ELECTRICAL SYSTEM. FAILURE TO DO SO COULD CAUSE DAMAGE TO MACHINE OR SERIOUS INJURY. CONTACT NFE FOR ALL REPAIRS.

Keep equipment in good repair by adopting a regular maintenance program.

On a daily basis, complete the following:

- Examine the general condition of equipment.
- Inspect guards, switches, and cords for damage.
- Check for loose screws, misalignment, binding of moving parts, improper mounting, broken parts and any other conditions that may affect safe operation.

If abnormal noise or vibration occurs, turn the equipment off immediately and have the problem corrected before further use. Do not use damaged equipment. Tag damaged equipment "DO NOT USE" until repaired.

During maintenance checks or regular inspections, complete the following:

- Perform mechanical inspection.
- Clean pulleys, spindles, bearings, housing, etc.
- Perform electrical inspection (switch, cord, plugs, etc.).
- Check nuts on shock absorbers and bottom plates.
- Check all screws and fittings for a tight and secure fit.
- Sharpen dull blades.
- Clean dust and debris from vents.
- Keep the equipment handle clean, dry, and free of oil or grease.

Use only mild soap and a damp cloth to clean. Some cleaning agents and solvents are harmful to plastic and insulated parts. Do not clean with: gasoline, turpentine, lacquer thinner, paint thinner, chlorinated cleaning solvents, ammonia, or any household detergents containing ammonia. Never use flammable or combustable solvents around equipment.

**Note:** Machine is pressure washable. Motor, motor junction box, capacitor box, and switch are protected from splashes of water but must not be subjected to jets of high pressure. Thoroughly dry machine before use. Do not use machine when wet or damp.

# Parts List and Diagrams

## OVERALL MACHINE

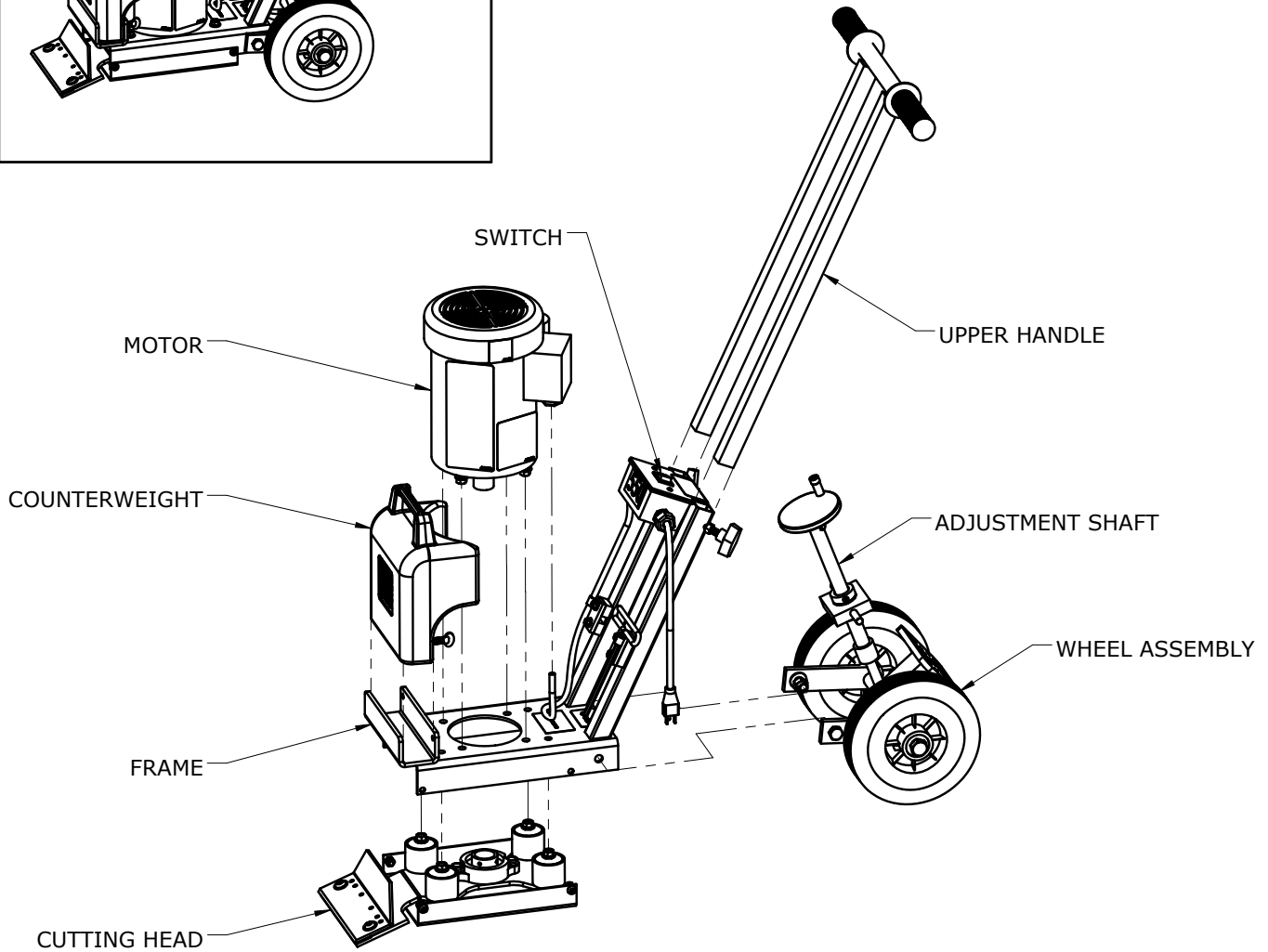
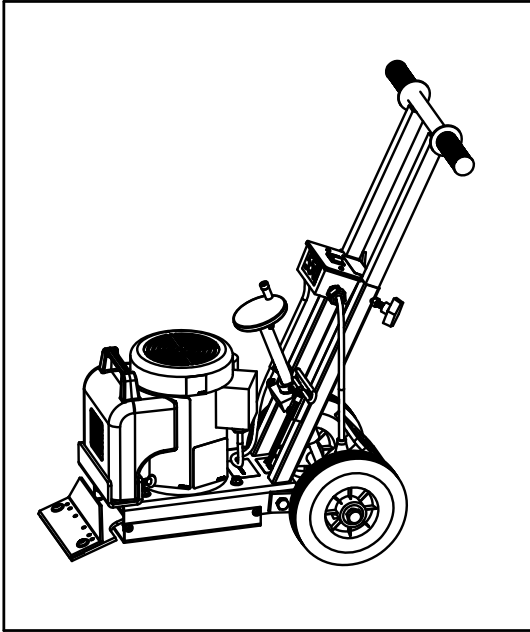



# Parts List and Diagrams

## FRAME AND WHEEL ASSEMBLY

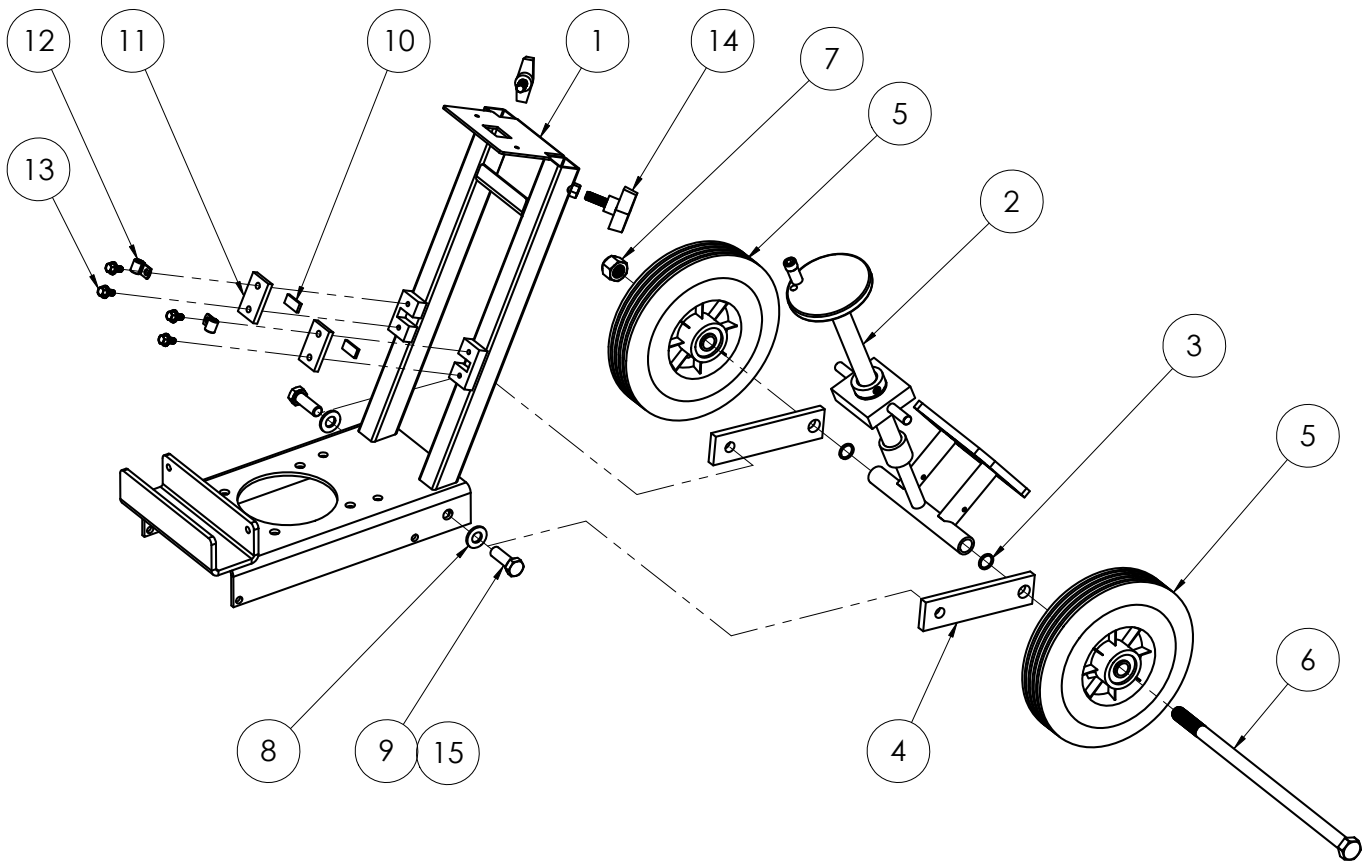

ITEM NO.	PART NUMBER	DESCRIPTION	QTY.
1		BASE, WELDMENT, SILVER VEIN BASE, WELDMENT, GREEN BASE, WELDMENT, ORANGE	1
2	550-11	ASSEMBLY, WHEEL ADJUSTMENT	1
3	72901	O RING 113	2
4	500-25	BRACKET, WHEEL LEG	2
5	550-29	WHEEL, SILVER METAL	2
6	73521	BOLT, HEX HEAD 5/8-11X14	1
7	73525	NUT, HEX, NYLON INSERT, 5/8-11	1
8	73424	WASHER, FLAT, ZINC SAE 1/2	2
9	73406	SCREW, HEX HEAD CAP, 1/2-13X1-1/4	2
10	402380	DAMPER, RUBBER	2
11	550-8	COVER, BRACKET	2
12	63-P30	CLAMP, WIRE 3/8	2
13	73001	BOLT, WIZLOCK, 1/4-20X1/2	4
14	73240	T-KNOB, 3/8-16	2
15	73402	NUT, HEX, NYLON INSERT, 1/2-13	2

# Parts List and Diagrams

## 550-11 WHEEL ADJUSTMENT ASSEMBLY

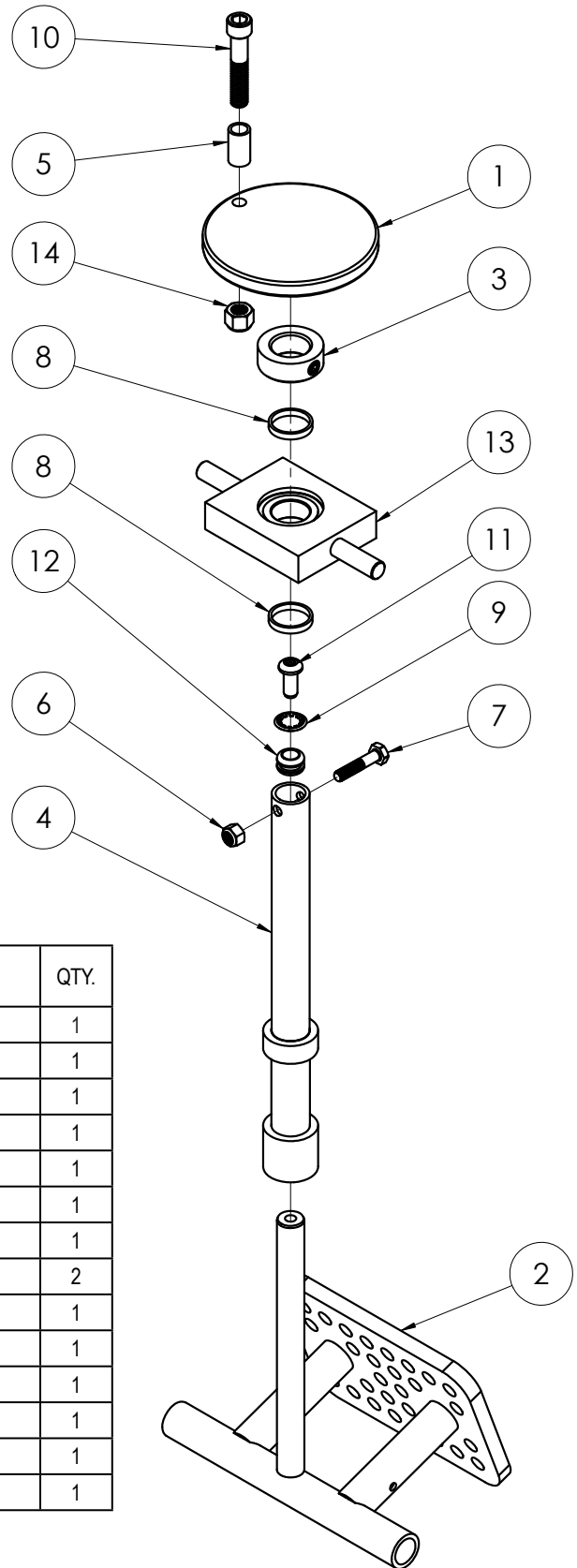
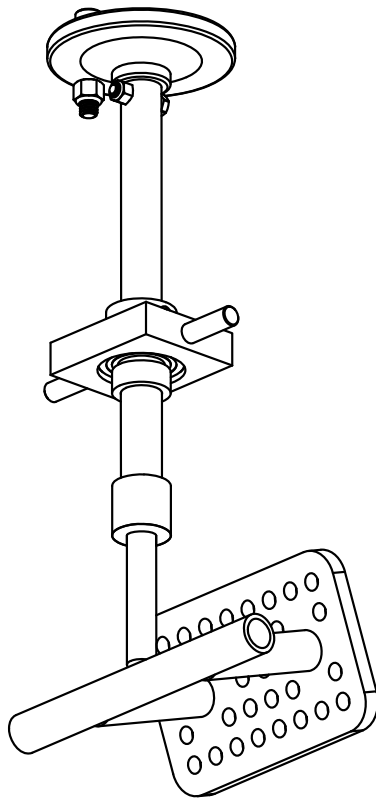

ITEM NO.	PART NUMBER	DESCRIPTION	QTY.
1	404823	WHEEL, ADJUSTMENT, 3"	1
2	550-4	T-BAR, ADJUSTMENT	1
3	550-5B	COLLAR, SHAFT 7/8	1
4	550-6	SHAFT, ADJUSTMENT	1
5	5600-83	SPACER, ROUND, .382 X .500 X .875, ALUMINUM	1
6	73008	NUT, HEX, NYLON INSERT, 1/4-20	1
7	73013	SCREW, HEX HEAD CAP, 1/4-20X1-1/4	1
8	73102	SPACER, .16X10DX.88 ID	2
9	73202	WASHER, INTERNAL LOCK 3/8	1
10	73249	SCREW, SOCKET HEAD CAP 3/8-16X2	1
11	73308	SCREW, BUTTON HEAD CAP, 5/16-18X3/4	1
12	74749	GROMMET, RUBBER 3/8"	1
13	404292	PLATE, SWIVEL, WITH BEARING	1
14	73207	NUT, HEX, NYLON INSERT, 3/8-16	1

# Parts List and Diagrams

## CUTTING HEAD

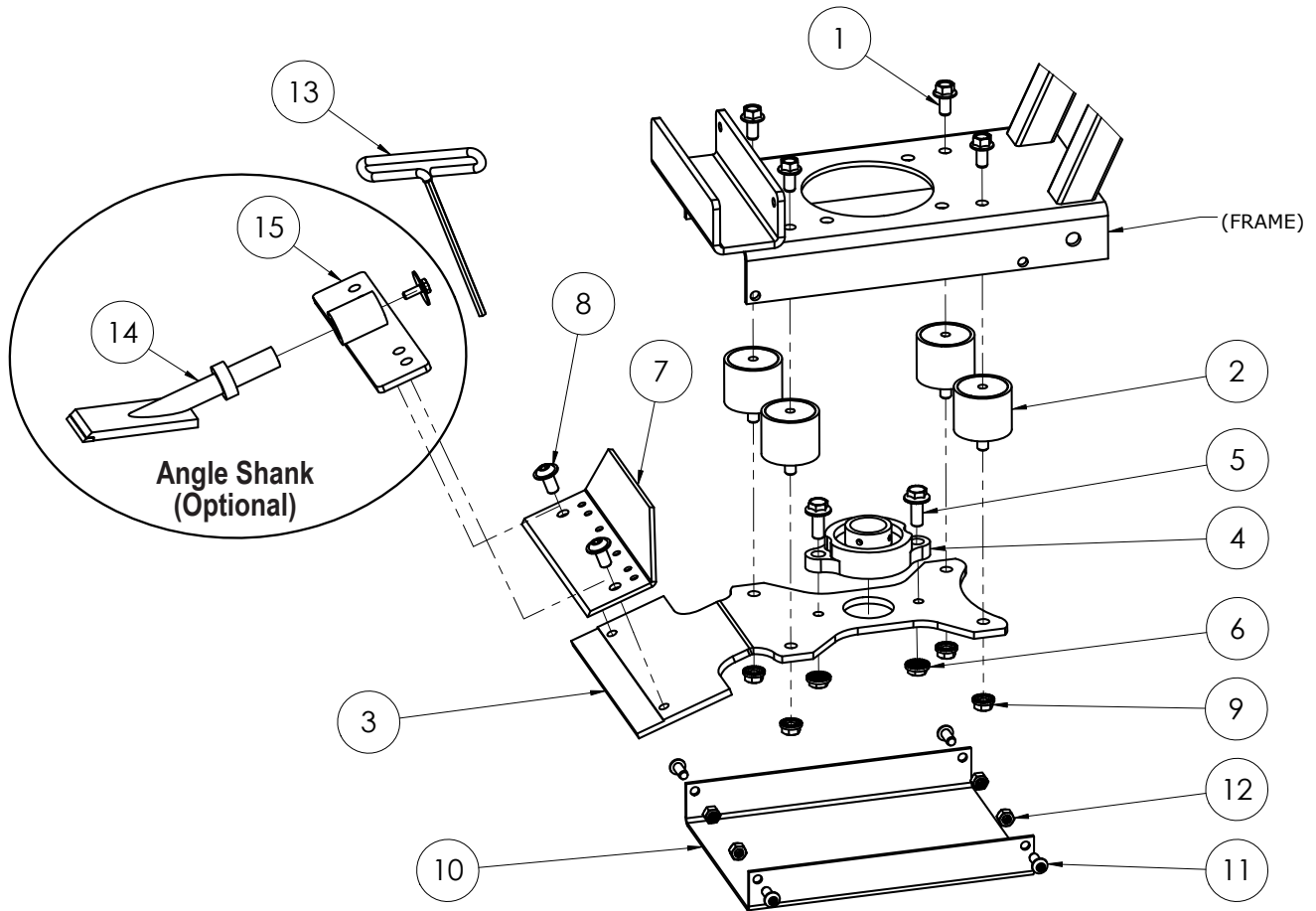

ITEM NO.	PART NUMBER	DESCRIPTION	QTY.
1	73259	BOLT, WIZLOCK, 3/8-16X3/4	4
2	70810	ISOLATOR, VIBRATION	4
3	5280-8	HEAD, CUTTING	1
4	71131	BEARING 1-1/4 ID, SBLF 206-20	1
5	74651	BOLT, WIZLOCK, M10-1.5 X 30MM, CLASS 8.8	2
6	74654	NUT, FLANGE, LOCK, M10	2
7	5280-136	COVER, BLADE	1
8	404281	SCREW, BUTTON HEAD CAP, M10-1.5X20, FLANGED, CLEAR ZINC	2
9	73211	NUT, FLANGE, SERRATED, 3/8-16	4
10	505-1000	COVER, BOTTOM PLATE	1
11	73308	SCREW, BUTTON HEAD CAP, 5/16-18X3/4	4
12	73322	NUT, HEX, NYLON INSERT, 5/16-18	4
13	5280-137W	WRENCH, BLADE, 6MM	1
14	552	SHANK, ANGLE W/ CARBIDE, 2" X 4" X 3/4" SHAFT	1
15	551	HOLDER, ANGLE SHANK, OPTIONAL	1

# Parts List and Diagrams

## MOTOR

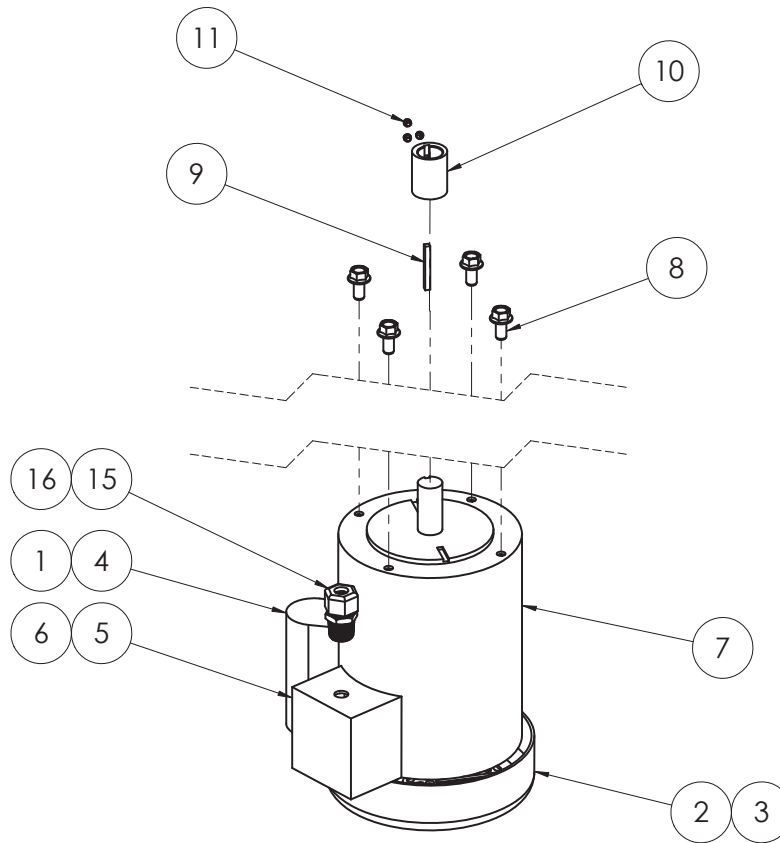

ITEM NO.	550-10XXXX 550-12XXXX 550-23XXXX	550-11XXXX 550-13XXXX 550-15XXXX 550-20XXXX 550-29XXXX	DESCRIPTION	QTY.
1	550-23		CAPACITOR, 540-648 $\mu$ F, 125VAC, 50/60HZ	1
		404928	CAPACITOR, START, 50HZ	
2		400001	COVER, MOTOR FAN, TOP MOUNT SCREWS, PAINTED	1
3		62181	FAN, MOTOR	1
4		62182	COVER, CAPACITOR, LEESON	1
5	401698		BOX, JUNCTION, MOTOR, 3" X 3.3"	1
		404929	BOX, CONDUIT, 50HZ	
6	401699		COVER, JUNCTION BOX, MOTOR, 3" X 3.3"	1
		404930	COVER, BOX, CONDUIT, 50HZ	
7	72351		MOTOR 1 HP, 116691.00	1
		404743	MOTOR, 1 HP, 115/230V, 50HZ	
8		73259	BOLT, WIZLOCK, 3/8-16X3/4	4
9		73902	KEY, 3/16X3/16X1-3/4	1
10		550-101	ECCENTRIC, 1.250 OD X .875 ID	1
11		73039	SCREW, SET, CUP POINT, 1/4-20X3/16	3
12*		72810	CAP, SPLICE, CRIMP, 10-18AWG, NON-INSULATED	2
13*		72811	INSULATOR, SPLICE CAP, 10-18AWG, NYLON	2
14*		74730	GROMMET, RUBBER 5/8"	1
15		73502	STRAIN RELIEF, STRAIGHT 1/2 INCH, .3376-.5686	1
16		73401	LOCKNUT, CONDUIT, 1/2"	1

\*NOT SHOWN

# Parts List and Diagrams

## SWITCH—DOMESTIC MACHINES

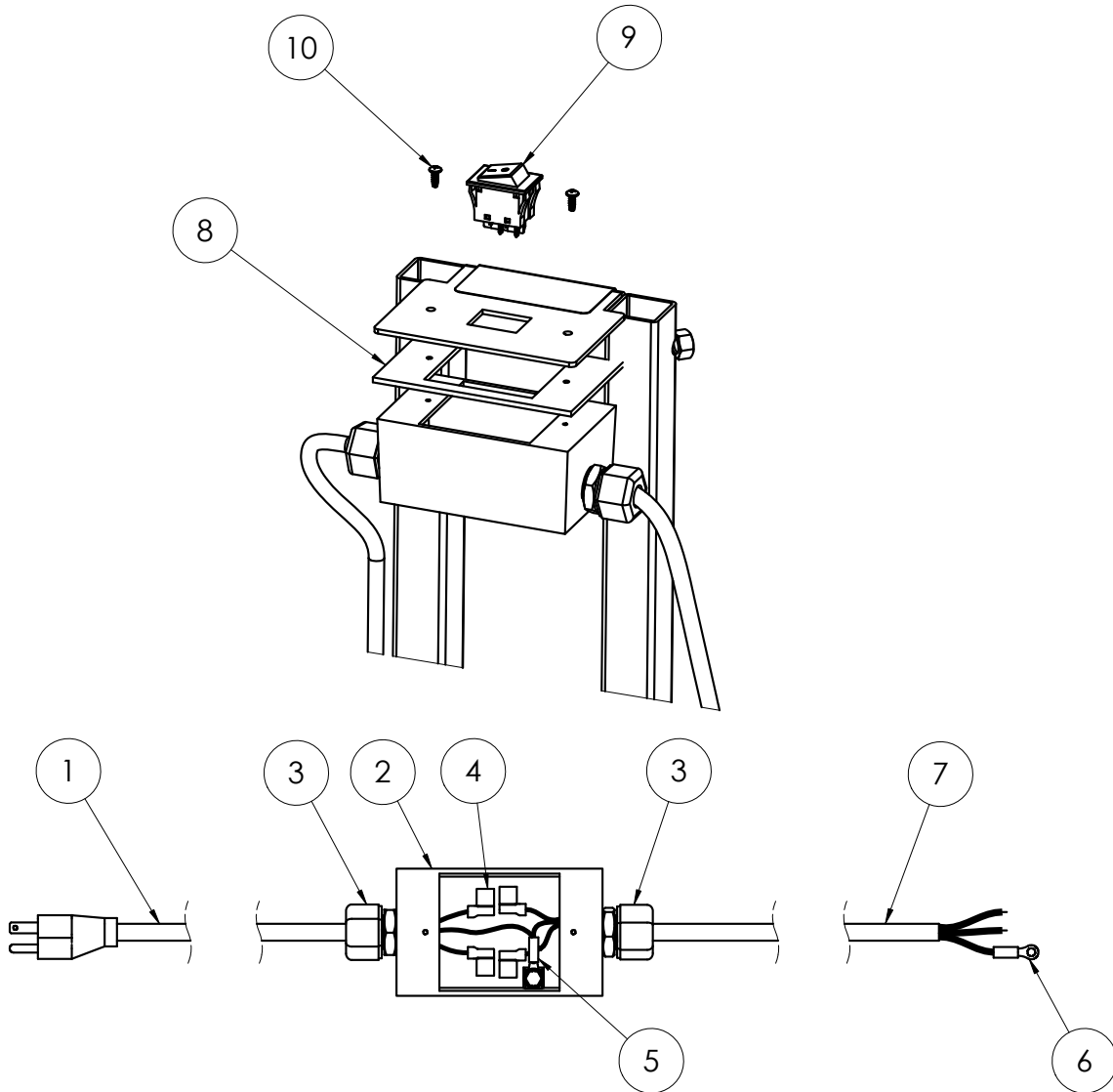

ITEM NO.	550-10XXXX 550-12XXXX 550-23XXXX	DESCRIPTION	QTY.
1	404769	CORD, POWER, MOLDED 5-15P PLUG, 15.5"	1
2	550-15	BOX, ELECTRICAL WITHOUT COVER	1
3	73502	STRAIN RELIEF, STRAIGHT 1/2 INCH, .3376-.5686	2
4	92819	TERMINAL, QUICK CONNECT, FEMALE, 90° FLAG, 14-16AWG, .250"X.032" TAB, FULLY INSULATED	4
5	72768	WIRE, GPT, 14AWG, RED, 50VDC, PVC	1
6	72821	TERMINAL, RING, 16-14 GAUGE, NYLON, 10 STUD	1
7	72565	CORD, POWER, SJOOW, 14/3, BLACK	2.5'
8	550-18	GASKET, ELECTRICAL BOX	1
9	6280-207	SWITCH, ON-OFF	1
10	74510	SCREW, PHILLIPS PAN HEAD, 6-32 X 3/8, THREAD ROLLING	2

# Parts List and Diagrams

## SWITCH—INTERNATIONAL MACHINES

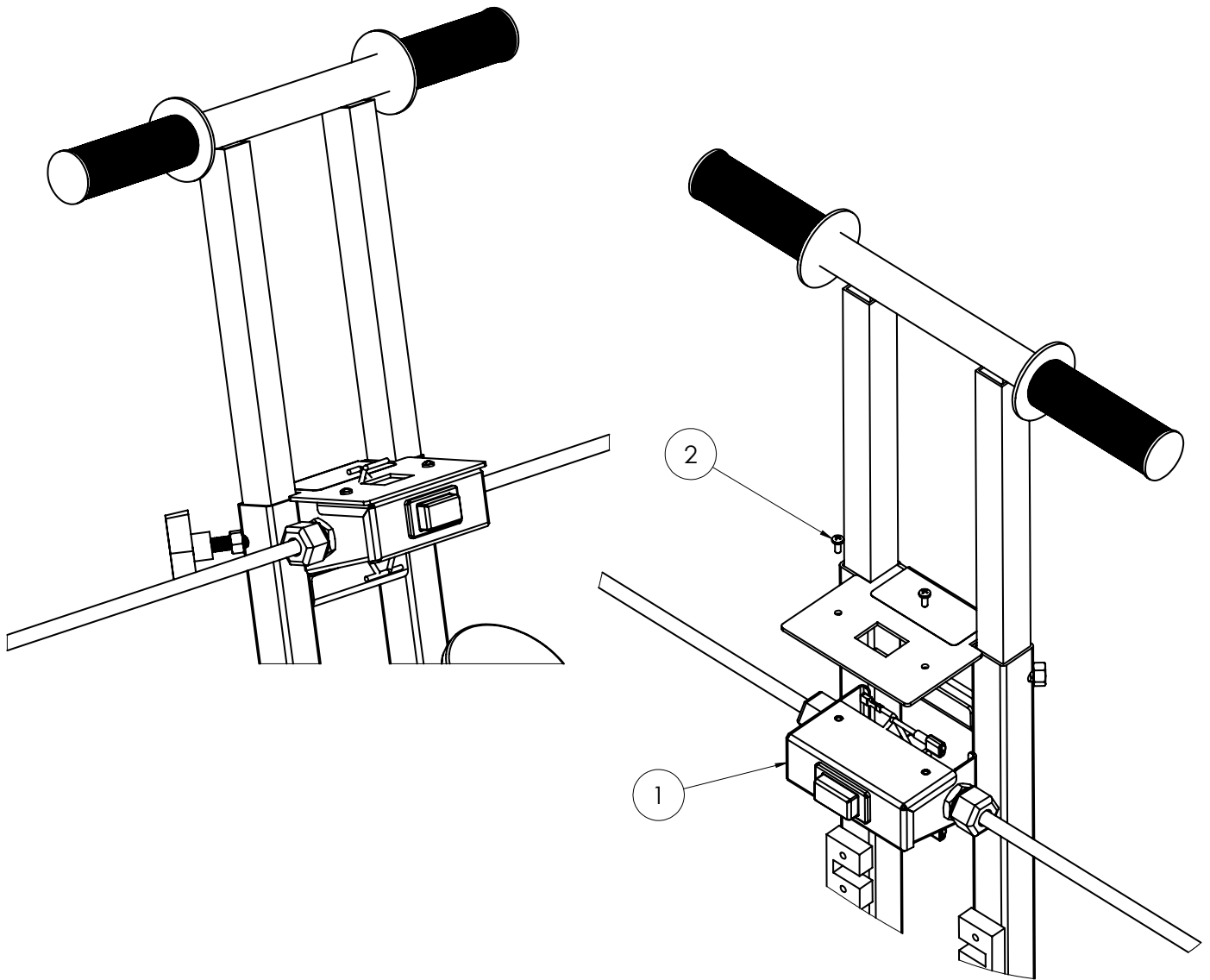

ITEM NO.	550-20XXX	550-11XXX 550-15XXX	550-13XXX	550-29XXX	DESCRIPTION	QTY.
1	404175				ASSEMBLY, ELECTRICAL BOX, UK	1
		404176			ASSEMBLY, ELECTRICAL BOX, EUR	1
			404177		ASSEMBLY, ELECTRICAL BOX, AUS	1
				404178	ASSEMBLY, ELECTRICAL BOX, SIN	1
2	403075				SCREW, PHILLIPS PAN HEAD, M4-0.7X10, CLEAR ZINC	2

# Parts List and Diagrams

## SWITCH—INTERNATIONAL MACHINES (CONTINUED)

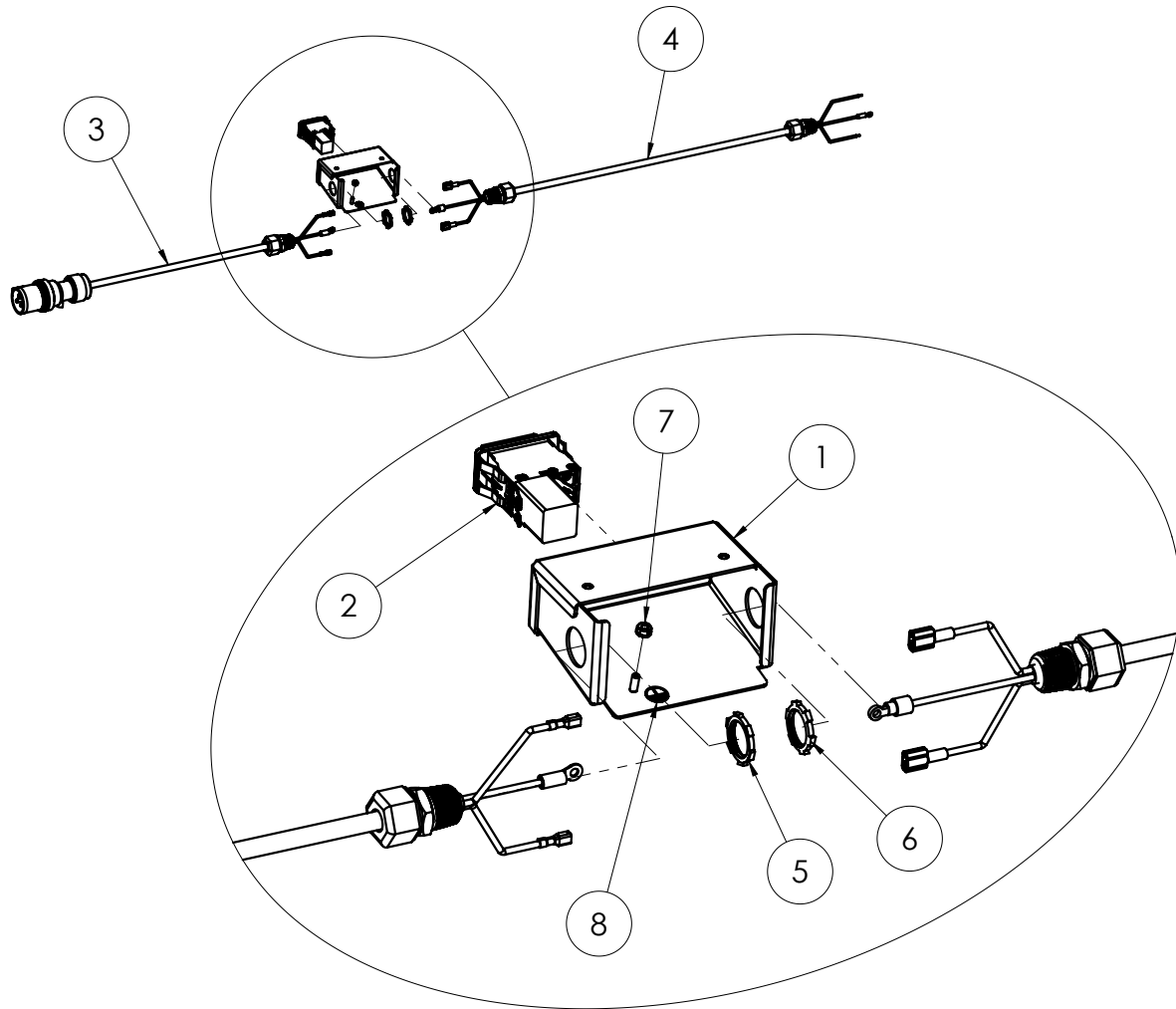

ITEM NO.	550-20XXXX	550-11XXXX 550-15XXXX	550-13XXXX	550-29XXXX	DESCRIPTION	QTY.
1	404158				BOX, SWITCH, ON/OFF, CE	1
2	404144				SWITCH, ROCKER BREAKER, 18A, 90-120V, UVR	1
		404180			SWITCH, ROCKER BREAKER, 10A, 220-240V, UVR	1
3	404171				ASSEMBLY, CORD, POWER, 2.5MM/3, IEC 309 110V/16A, 50FT	1
		404172			ASSEMBLY, CORD, POWER, 1.5MM/3, EU1-16P, 15IN	1
			404173		ASSEMBLY, CORD, POWER, 1MM/3, AUS1-16P, 15IN	1
				404174	ASSEMBLY, CORD, POWER, 1.5MM/3, UK1-13P, 15IN	1
4	404146				ASSEMBLY, MOTOR CORD, H05VV-F, 2.5MM/3, 30IN	1
5	73401				LOCKNUT, CONDUIT, 1/2"	1
6	73401				LOCKNUT, CONDUIT, 1/2"	1
7	403281				NUT, KEPS, M4-0.7, CLEAR ZINC	1
8	403086				LABEL, GROUND	1

# Parts List and Diagrams

## COUNTERWEIGHT

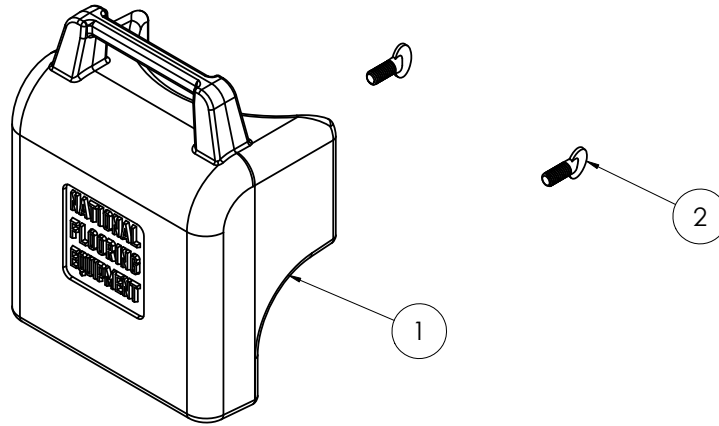

ITEM NO.	550-10XXXX 550-11XXXX 550-13XXXX 550-20XXXX 550-23XXXX 550-29XXXX	550-12XXXX	550-15XXXX	DESCRIPTION	QTY.
1	550-28-SV			COUNTERWEIGHT, FRONT, CAST, SILVER VEIN	1
		550-28-G		COUNTERWEIGHT, FRONT, CAST, GREEN	
			550-28-O	COUNTERWEIGHT, FRONT, CAST, ORANGE	
2	73273		SCREW, THUMB, 3/8-16X3/4	2	

## UPPER HANDLE

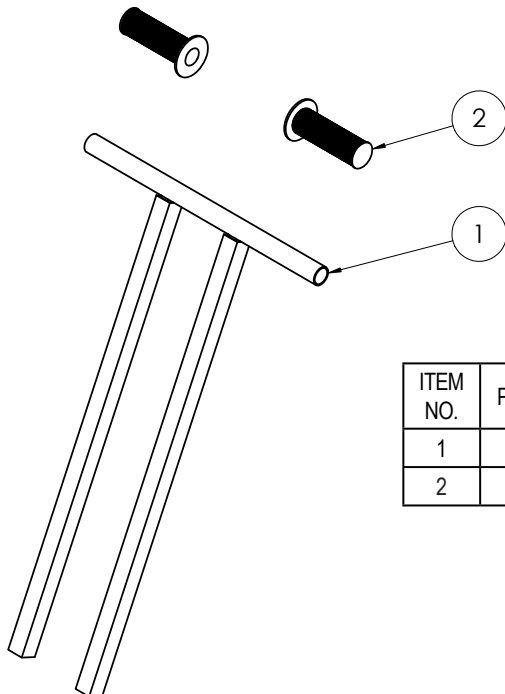

ITEM NO.	PART NUMBER	DESCRIPTION	QTY.
1	62140	HANDLE, UPPER	1
2	404931	GRIP, HANDLE, 1" ID	2



# Parts List and Diagrams

## LABELS

ITEM NO.	550-10XXXX 550-12XXXX	550-23XXXX	550-11XXXX 550-13XXXX 550-15XXXX 550-29XXXX	550-20XXXX	DESCRIPTION	QTY.
1*	403356-XX				KIT, LABELS, 550 [LANGUAGE]	1
2		402627			LABEL, 1.5 X 2	3
3			403866		LABEL, CE, 550, 230V, 50HZ	1
4				403867	LABEL, CE, 550, 110V, 50HZ	1

\*Suffix denotes language: None=English; -FR=French; -NL=Dutch; -DE=German.

## ACCESSORIES

ITEM NO.	PART NUMBER	DESCRIPTION	QTY.
1	5170	KIT, BLADES, 550	1

# Parts List and Diagrams

## WIRING DIAGRAM—120V DOMESTIC

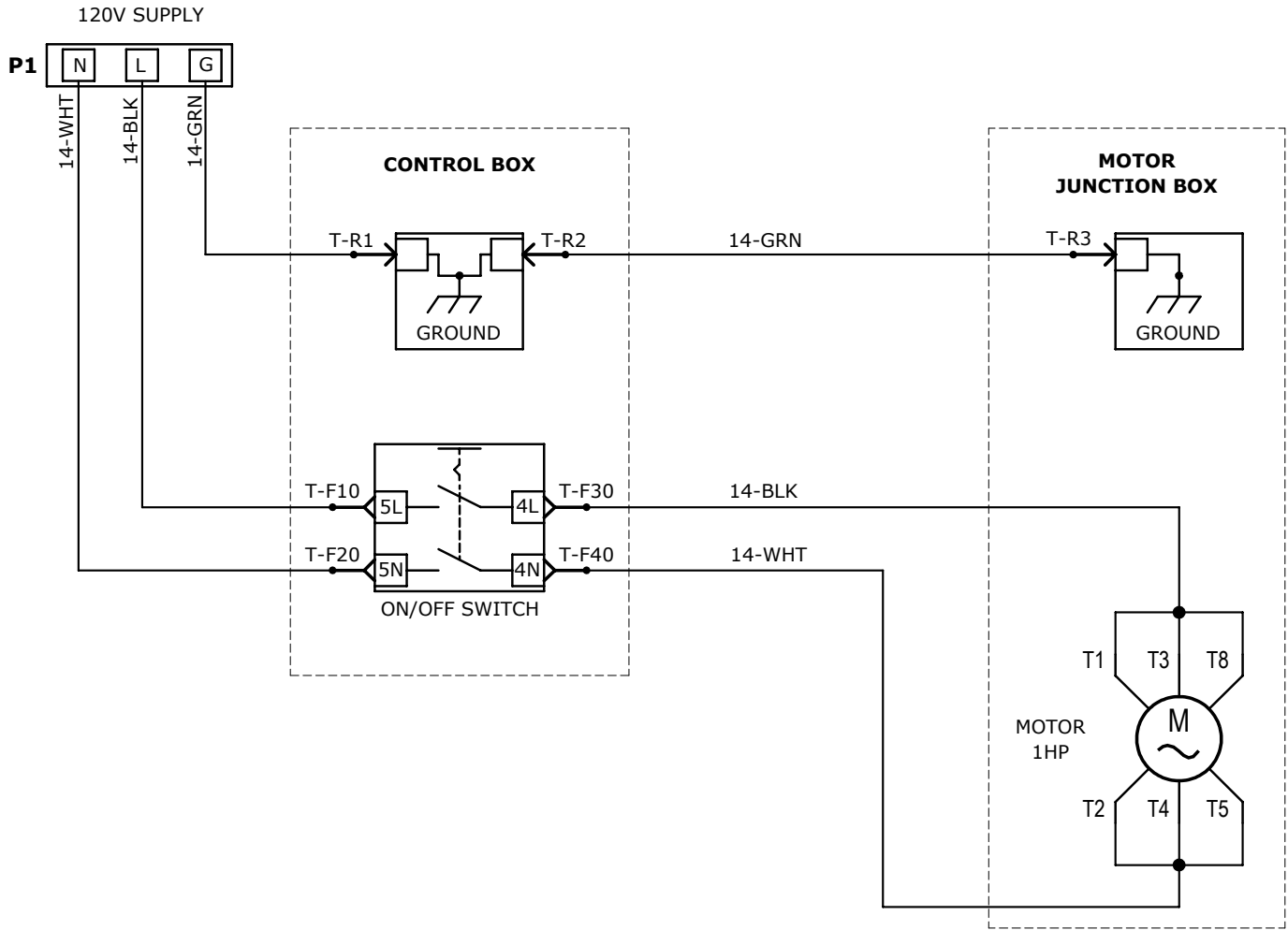

# Parts List and Diagrams

## WIRING DIAGRAM—230V INTERNATIONAL

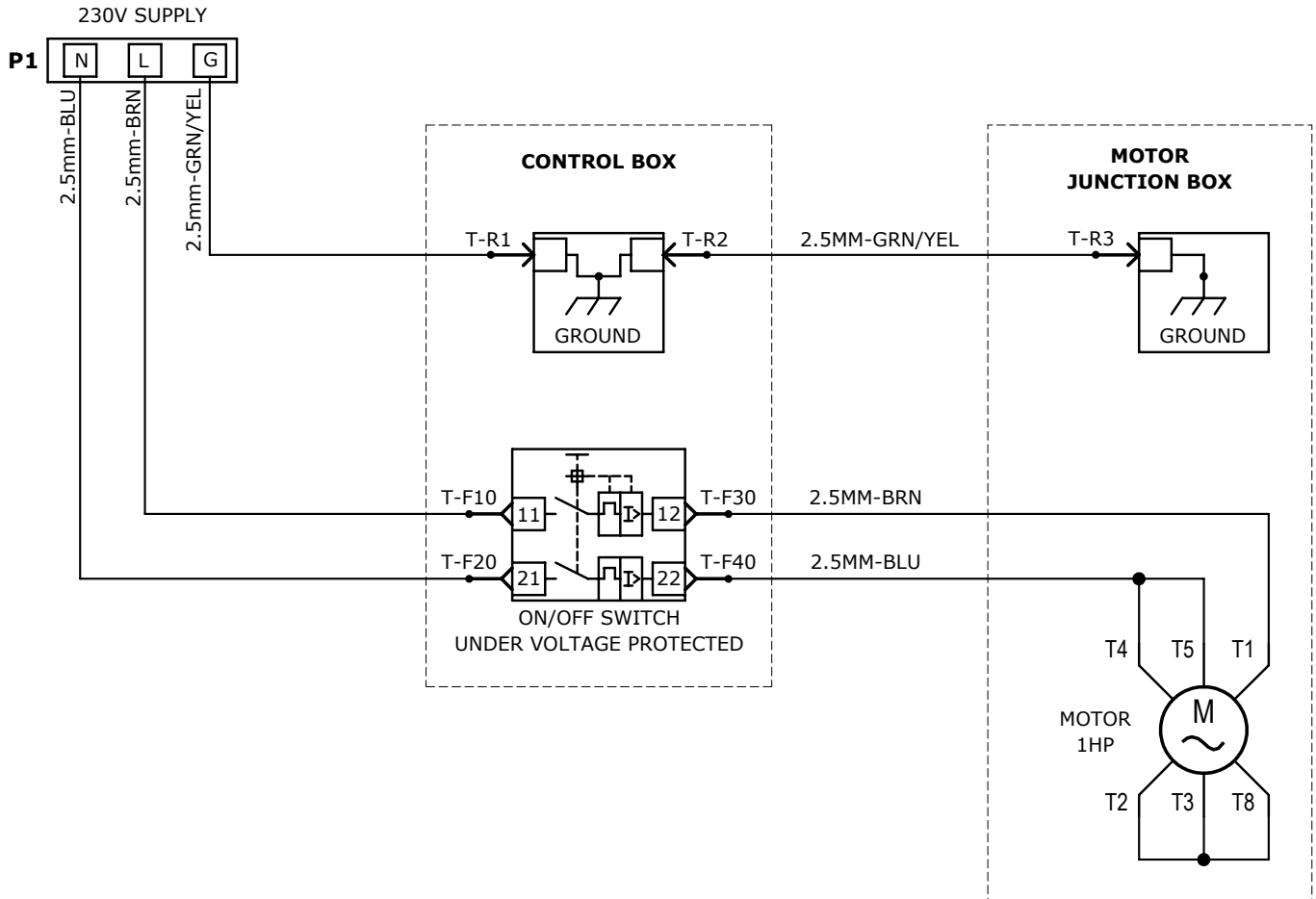

# Parts List and Diagrams

## WIRING DIAGRAM—110V INTERNATIONAL

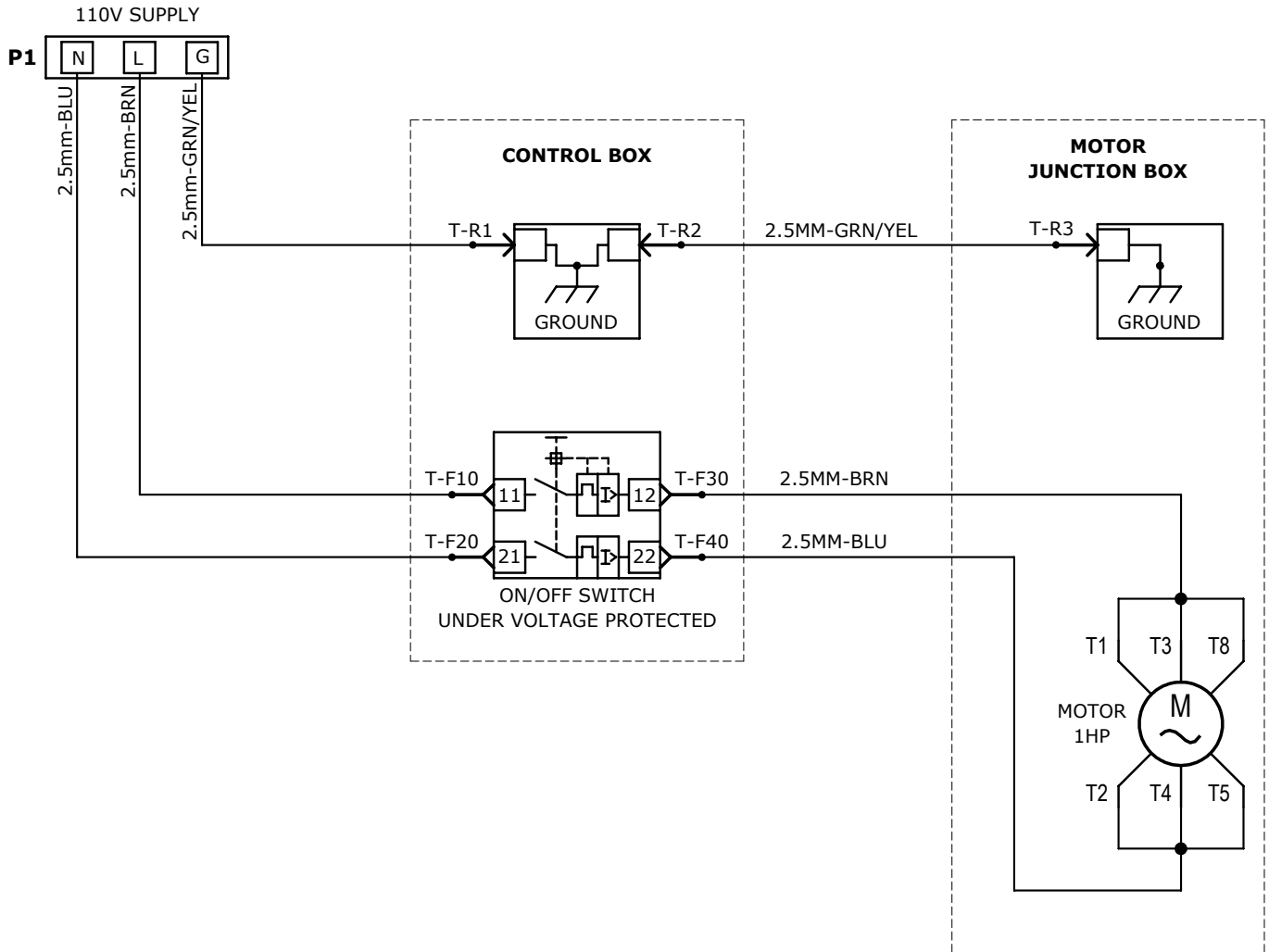

# Warranty

---

National Flooring Equipment Inc. (referred to as "The Company") warrants that each new unit manufactured by The Company to be free from defects in materials and workmanship in normal use and service for a period of twelve (12) months from date of shipment from The Company to the end user. If shipment to end user is from a Distributor, The Company may honor warranty for up to 15 months from initial shipment from the Company if the end user can provide documentation of receipt date. Accessories or equipment furnished and installed on the product by the Company but manufactured by others, including but not limited to: engines, motors, electrical components, transmissions etc., shall carry the accessory manufacturers own warranty. Battery warranties are prorated over the warranty period. Customer is responsible for the inspection of equipment or parts upon delivery. **Freight damages are excluded from this warranty.**

The Company, at its determination of defect, will repair or replace any product or part deemed to be defective in material or workmanship within specified warranty time period. All product determinations and / or repairs will take place at The Company repair facility or at a certified warranty location designated by The Company. The Company will coordinate and be responsible for all freight expenses associated with valid warranty claims. Freight and shipping expenses associated with abuse or misuse will be back charged to the Distributor/Customer. The Company reserves the right to modify, alter or improve any part / parts without incurring any obligation to replace any part / parts previously sold without such modified, altered or improved part / parts. In no event shall the seller or manufacturer of the product be liable for special, incidental, or consequential damages, including loss of profits, whether or not caused by or resulting from the negligence of seller and / or the manufacturer of the product unless specifically provided herein. **This warranty shall not apply to any products or portions there of which have been subjected to abuse, misuse, improper installation or operation, lack of recommended maintenance, electrical failure or abnormal conditions, and to products which have been tampered with, altered, modified, repaired, reworked by anyone not approved or authorized by the Company or used in any manner inconsistent with the provisions of the above or any instructions or specifications provided with or for the product.** Any and all unauthorized onsite warranty work conducted by unauthorized personnel or any outside person(s), is not covered by The Company unless the work has been pre-authorized by a predetermined manufacturer representative. This warranty excludes wearable parts and/or consumables.

Defective or failed material or equipment shall be held at the purchaser's premises until authorization has been granted by The Company to return or dispose of defective products. Products returned to The Company for inspection must be returned with a manufacturer authorized Return Material Authorization (RMA), and must be packaged to The Company's specifications to avoid damage during shipment. Any unauthorized return of equipment will be declined at the dock by The Company. Any non-approved items returned with approved returned items are subject to rejection and will not be credited. Credit will be issued for material found to be defective upon The Company's inspection based on prices at time of purchase.

**TO OBTAIN SERVICE CONTACT NATIONAL FLOORING EQUIPMENT, INC. TOLL FREE AT 800-245-0267 FOR A REPAIR AUTHORIZATION NUMBER. COD FREIGHT RETURNS WILL NOT BE ACCEPTED. FREIGHT COLLECT SHIPMENTS WILL NOT BE ACCEPTED. WARRANTY REPAIRS MUST BE ACCOMPANIED BY DATE OF PURCHASE RECEIPT AND A RETURN/REPAIR AUTHORIZATION NUMBER.**

**RETURN/REPAIR AUTHORIZATION NUMBER:** \_\_\_\_\_

**MACHINE SERIAL NUMBER:** \_\_\_\_\_







Made in America Since 1968

9250 Xylon Avenue N • Minneapolis, MN 55445 • U.S.A.  
Toll-free 800-245-0267 • Phone 763-315-5300 • Fax 800-648-7124 • Fax 763-535-8255  
Web Site: [www.nationalequipment.com](http://www.nationalequipment.com) • E-Mail: [info@nationalequipment.com](mailto:info@nationalequipment.com)