

# 4230 ELECTRIC RIDE-ON SCRAPER OPERATING & SERVICE MANUAL



Read Manual Before Operating or  
Servicing Machine

404732 Rev C



# Table of Contents

---

<b>Table of Contents</b> .....	<b>3</b>
<b>Features and Specifications</b> .....	<b>4</b>
<b>Safety</b> .....	<b>7</b>
General Rules For Safe Operation .....	7
Ride-On Scraper Safety Guidelines.....	8
Hydraulic Safety.....	9
Electrical Practices .....	10
<b>Components and Assembly</b> .....	<b>12</b>
Transport.....	12
Jobsite Movement.....	12
Cutting Head and Blades.....	13
Foot Pegs .....	15
<b>Operation</b> .....	<b>16</b>
Operating Controls.....	16
Startup Procedure.....	17
Shutdown Procedure .....	17
Slide Plate Adjustments and Settings .....	17
Steep Cutting Head Angle .....	18
Application Setup.....	18
Ditching.....	19
<b>Maintenance Schedule</b> .....	<b>20</b>
<b>Troubleshooting Guide</b> .....	<b>21</b>
<b>Maintenance</b> .....	<b>22</b>
Manual Slide Plate Removal.....	22
Dual Slide Plate Removal .....	22
Leak Maintenance .....	22
Check Hydraulic Oil Level.....	23
Hydraulic Oil Change Out.....	23
Change Tilt Hydraulic Cylinder .....	23
Change/Remove Hose .....	23
Change Pump.....	23
Change Valve .....	23
Change Wheel Motor.....	24
Change Rear Wheel .....	24
Change Caster.....	24
Change Electric Motor .....	24
Remove Front and Rear Hoods.....	25
Replace Seat .....	25
Remove/Replace Foot Peg.....	25
Clean Wheel Motor Build-Up .....	25
<b>Parts List and Diagrams</b> .....	<b>26</b>

# Features and Specifications

---

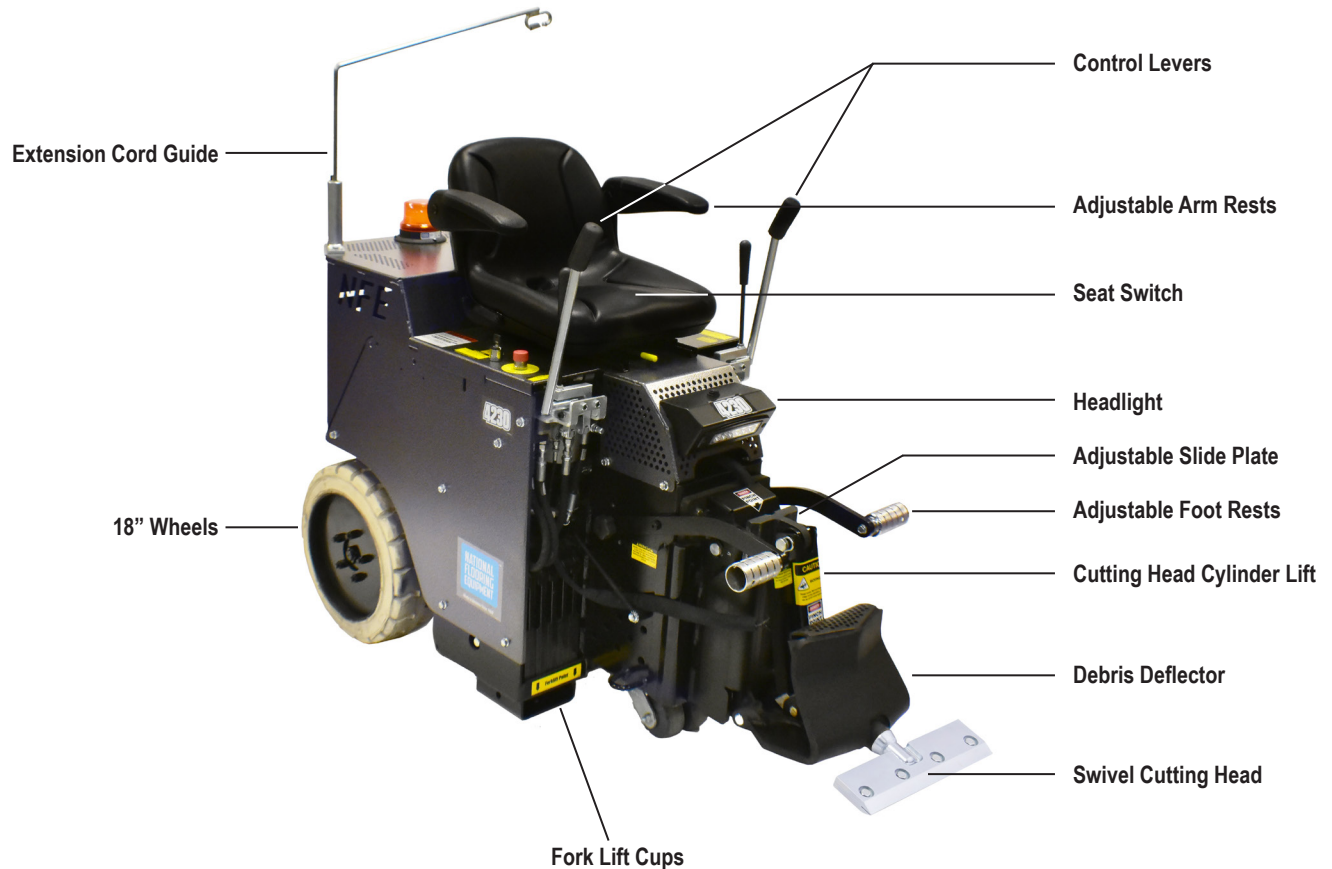

## FEATURES

**Seat Switch** - Ensures the machine will not function without someone in the operator seat.

**18" Wheels** - Designed to work on all types of applications, including debris build-up and slippery/slimy residue (e.g. double stick).

**Adjustable Slide Plate** - Affords maximum versatility in blade settings.

**Fork Lift Cups** - Makes it easier to load and unload on jobsites.

**Control Levers** - Move forward or in reverse, turn, and brake with easy-to-move levers.

**Adjustable Foot Rests** - Adjustable foot pegs provide optimal comfort and ergonomics.

**Cutting Head Cylinder Lift** - Changes the angle of the cutting head via the control handle next to the operator seat.

**Debris Deflector** - Redirects debris away from the operator.

**Swivel Cutting Head** - Ensures continuous blade contact with the floor.

**Adjustable Arm Rests** - Adjusts to operator's level of comfort.

**Headlight** - Illuminates work zone.

**Extension Cord Guide** - The cord guide is designed to keep track of the electrical cord, particularly when backing up and turning.

**Twin Motors** - Twin 1.5 HP motors remove up to 71 ft/min (21.6 m/min).

# Features and Specifications

## Product Specifications

Width	Length	Height	Weight (Machine Only)	Weight (Fully Weighted)	Removable Weight
24.5" (62.2 cm)	63" (160.0 cm)	48" (121.9 cm)	1144 lbs (518.9 kg)	1590 lbs (721.2 kg)	446 lbs (202.3 kg)
Power	Speed	Sound Level			
Twin 1.5 HP motors	Up to 71 ft/min (Up to 21.6 m/min)	94-97 dB(A)			

## Machine Variants

Region	Serial Number	Power / Frequency	Amps (Full Load)	Body Panels	Slide Plate
Europe	4230-11XXXX	230V / 50 Hz	16A	Silver Vein	Dual Lift
	4230-21XXXX	230V / 50 Hz	16A	Silver Vein	Manual Lift

Dual Lift



Manual Lift



THIS PAGE INTENTIONALLY LEFT BLANK

## GENERAL RULES FOR SAFE OPERATION

Before use, anyone operating or performing maintenance on this equipment must read and understand this manual, as well as any labels packaged with or attached to the machine and its components. Read the manual carefully to learn equipment applications and limitations, as well as potential hazards associated with this type of equipment. Keep manual near machine at all times. If your manual is lost or damaged, contact National Flooring Equipment (NFE) for a replacement.

### Personal

#### **Dress properly and use safety gear.**

Do not wear loose clothing; it may be caught in moving parts. Anyone in the work area must wear safety goggles or glasses and hearing protection. Wear a dust mask for dusty operations. Hard hats, face shields, safety shoes, etc. should be worn when specified or necessary.

#### **Maintain control; stay alert.**

Keep proper footing and balance, and maintain a firm grip. Observe surroundings at all times. Do not use when tired, distracted, or under the influence of drugs, alcohol, or any medication that may cause decreased control.

#### **Keep hands away from all moving parts and tooling.**

Wear gloves when changing tooling. Remove tooling when machine is not in use and/or lower cutting head to the floor.

#### **Do not force equipment.**

Equipment will perform best at the rate for which it was designed. Excessive force only causes operator fatigue, increased wear, and reduced control.

### Environment

#### **Avoid use in dangerous environments.**

Do not use in rain, damp or wet locations, or in the presence of explosive atmospheres (gaseous fumes, dust, or flammable materials). Remove materials or debris that may be ignited by sparks. Keep work area tidy and well-lit - a cluttered or dark work area may lead to accidents. Extreme heat or cold may affect performance.

#### **Protect others in the work area and be aware of surroundings.**

Provide barriers or shields as needed to protect others from debris and machine operation. Children and other bystanders should be kept at a safe distance from the work area to avoid distracting the operator and/or coming into contact with the machine. Operator should be aware of who is around them and their proximity. Support personnel should never stand next to, in front of, or behind the machine while the machine is running. Operator should look behind them before backing up.

#### **Do not come within 3 ft. of the machine's perimeter during operation.**

#### **Guard against electric shock.**

Ensure that machine is connected to a properly grounded outlet. Prevent bodily contact with grounded surfaces, e.g. pipes, radiators, ranges, and refrigerators. When scoring or making cuts, always check the work area for hidden wires or pipes.

### Maintenance & Repairs

#### **Begin maintenance work only when the machine is shut down, unplugged, and cooled down.**

#### **Use proper cleaning agents.**

Ensure that all cleaning rags are fiber-free; do not use any aggressive cleaning products.

#### **Schedule regular maintenance check-ups.**

Ensure machine is properly cleaned and serviced. Remove all traces of oil, combustible fuel, or cleaning fluids from the machine and its connections and fittings. Retighten all loose fittings found during maintenance and repair work. Loose or damaged parts should be replaced immediately; use only NFE parts.

#### **Do not weld or flame-cut on the machine during repairs, or make changes to machine without authorization from NFE.**

### Equipment

#### **Use proper parts and accessories.**

Only use NFE-approved or recommended parts and accessories. Using any that are not recommended may be hazardous.

#### **Ensure accessories are properly installed and maintained.**

Do not permanently remove a guard or other safety device when installing an accessory or attachment.

#### **Inspect for damaged parts.**

Check for misalignment, binding of moving parts, loose fasteners, improper mounting, broken parts, and any other conditions that may affect operation. If abnormal noise or vibration occurs, turn the machine off immediately. Do not use damaged equipment until repaired. Do not use if power switch does not turn machine on and off. For all repairs, insist on only identical NFE replacement parts.

#### **Maintain equipment and labels.**

Keep handles dry, clean, and free from oil and grease. Keep cutting edges sharp and clean. Follow instructions for lubricating and changing accessories. Motor and switches should be completely enclosed at all times with no exposed wiring. Inspect cord regularly. Labels carry important information; if unreadable or missing, contact NFE for a free replacement.

#### **Avoid accidental starting; store idle equipment.**

When not in use, ensure that the machine is unplugged and breaker is set to OFF. Store in a dry, secured place. Remove tooling when storing, and keep away from children.

# Safety

---

## RIDE-ON SCRAPER SAFETY GUIDELINES

### Scraping

**Do not drive machine along hills or uneven surfaces.**

The weight of the machine may become distributed differently if on an uneven surface. Too much of an angle could make the machine unsafe or cause it to tip over. Always keep the front of the machine facing downward while traveling up or down ramps or inclines. Do not run the machine in unsafe environments.

**Inspect work area for potential hazards prior to operation.**

**Observe location of electrical supplies and extension cords.**

Do not allow cutting heads to come into contact with any electrical supply or extension cord.

**Operator must be seated before starting machine and should stay seated until motor has stopped running.**

This machine is equipped with a safety switch under the seat, which requires the operator to be seated before the machine can be operated. Do not attempt the start-up procedure without first being seated on the machine.

	<p><b>WARNING:</b> GRINDING/CUTTING/DRILLING OF MASONRY, CONCRETE, METAL AND OTHER MATERIALS CAN GENERATE DUST, MISTS AND FUMES CONTAINING CHEMICALS KNOWN TO CAUSE SERIOUS FATAL INJURY OR ILLNESS, SUCH AS RESPIRATORY DISEASE, CANCER, BIRTH DEFECTS OR OTHER REPRODUCTIVE HARM. IF YOU ARE UNFAMILIAR WITH THE RISKS ASSOCIATED WITH THE PARTICULAR MATERIAL BEING CUT, REVIEW THE MATERIAL SAFETY DATA SHEET AND/OR CONSULT YOU EMPLOYER, THE MATERIAL MANUFACTURER/SUPPLIER, GOVERNMENTAL AGENCIES SUCH AS OSHA AND NIOSH AND OTHER AUTHORITIES ON HAZARDOUS MATERIALS. CALIFORNIA AND SOME OTHER AUTHORITIES, FOR INSTANCE, HAVE PUBLISHED LISTS OF SUBSTANCES KNOWN TO CAUSE CANCER, REPRODUCTIVE TOXICITY, OR OTHER HARMFUL EFFECTS. CONTROL DUST, MIST AND FUMES AT THE SOURCE WHERE POSSIBLE. IN THIS REGARD USE GOOD WORK PRACTICES AND FOLLOW THE RECOMMENDATIONS OF THE MANUFACTURER/SUPPLIER, OSHA/NIOSH, AND OCCUPATIONAL AND TRADE ASSOCIATIONS. WHEN THE HAZARDS FROM INHALATION OF DUST, MISTS AND FUMES CANNOT BE ELIMINATED, THE OPERATOR AND ANY BYSTANDERS SHOULD ALWAYS WEAR A RESPIRATOR APPROVED BY OSHA/MSHA FOR THE MATERIAL BEING CUT.</p>
--	---



## HYDRAULIC SAFETY

### Maintaining a Safe Work Environment

Establishing a safe work environment in and around your hydraulic equipment is extremely important. The easiest and most effective way to avoid problems is to make sure associates understand their equipment, know how to operate the machines safely, and recognize the dangers if handled carelessly. A few things to be aware of are:

- **Pressure:** Hydraulic fluid under pressure is dangerous and can cause serious injury. Never look for a leak when unit is under pressure. Using your hand could cause serious injury. A few common ways to encounter hydraulic fluid under pressure include:
  - Pinhole: Fluid under pressure can cause serious injury. It can be almost invisible escaping from a pinhole, and it can pierce the skin into the body.



**DANGER:** DO NOT TOUCH A PRESSURIZED HYDRAULIC HOSE ASSEMBLY WITH ANY PART OF THE BODY. IF FLUID PUNCTURES THE SKIN, EVEN IF NO PAIN IS FELT, A SERIOUS EMERGENCY EXISTS. OBTAIN MEDICAL ASSISTANCE IMMEDIATELY. FAILURE TO DO SO COULD RESULT IN LOSS OF THE INJURED BODY PART OR DEATH.

- Leak: Keep fittings and hoses tight. Only check and service when not under pressure. Leaking hydraulic fluid is hazardous; in addition to making workplace floors slippery and dangerous, it also contaminates the environment. Before cleaning an oil spill, always check EPA, state, and local regulations.
  - Burst: Whether due to improper selection or damage, a ruptured hose can cause injury. If it bursts, a worker can be burned, cut, injected, or may slip and fall.
  - Coupling Blow-Off: If the assembly is not properly made or installed, the coupling could come off and hit or spray a worker, possibly resulting in serious injury. Never operate machine without guards.
- **Flammability:** When ignited, some hydraulic fluids can cause fires and/or explode. With the exception of those comprised primarily of water, all hydraulic fluid is flammable (including many “fire-resistant” hydraulic fluids) when exposed to the proper conditions. Leaking pressurized hydraulic fluids may develop a mist or fine spray that can flash or explode upon contact with a source of ignition. These explosions can be very severe and could result in serious injury or death. Precautions should be taken to eliminate all ignition sources from contact with escaping fluids, sprays or mists resulting from hydraulic failures. Sources of ignition could be electrical discharges (sparks), open flames, extremely high temperatures, sparks caused by metal-to-metal contact, etc.



**CAUTION:** NEVER USE YOUR HANDS TO CHECK FOR LEAKS OVER HOSE OR HYDRAULIC CONNECTIONS. USE A PIECE OF CARDBOARD TO LOCATE A PRESSURIZED LEAK. FOR LOW PRESSURE LEAKS (DRIPS), USE A RAG TO CLEAN THE AREA AND DETERMINE WHERE THE LEAK ORIGINATES.

- **Mechanical:** Hydraulic fluid creates movement, which means some equipment may move. Observe surroundings and equipment at all times.
- **Moisture:** Do not use in wet or high moisture conditions.
- **Electrical:** Faulty wiring can be an electrical hazard. A regular preventive maintenance program should always include a wiring check. If applicable, disconnect battery before servicing.
- **Temperature:** Because this machine operates at a relatively low pressure, overheating is not common. If surface of tank becomes too hot to touch by hand (above 130°F or 55°C), shut off machine and allow it to cool.

### Hydraulic Fluid

Only use Texaco Rando 46 Hydraulic Oil or compatible fluid like ISO or AW #46 from a brand name manufacturer. Non-compatible fluids could cause damage to unit or serious injury.

# Safety

---

## ELECTRICAL PRACTICES



**WARNING:** ELECTRICAL CORDS CAN BE HAZARDOUS. MISUSE CAN RESULT IN FIRE OR DEATH BY ELECTRICAL SHOCK. READ CAREFULLY AND FOLLOW ALL DIRECTIONS.



**CAUTION:** ALWAYS FOLLOW APPLICABLE ELECTRICAL CODES, STANDARDS AND/OR REGULATIONS. CONSULT YOUR LOCAL ELECTRICAL AUTHORITY OR A LICENSED ELECTRICIAN BEFORE ATTEMPTING TO MODIFY AN ELECTRICAL INSTALLATION. ENSURE THAT CIRCUIT AND GROUND FAULT PROTECTION DEVICES AND ALL OTHER ELECTRICAL SAFETY EQUIPMENT ARE FUNCTIONING PROPERLY.

### Extension Cord Requirements

- Ensure the cord type is suitable for the application and location. If you are unsure about your cord type, consult a qualified electrical professional or electrician.
- Ground your equipment. The equipment must be plugged into an appropriate outlet, one which is properly installed and grounded in accordance with all codes and ordinances. Do NOT modify the plug provided with the equipment. Never remove the grounding prong from the plug.
- Do not remove, bend or modify any metal prongs or pins of the plug. Modifications to power cords and/or plugs may result injury and/or equipment damage.
- FULLY INSERT plug into outlet.
- Do not use excessive force to make connections.
- Never unplug by pulling the cord from the outlet. Pull plug rather than cord to reduce the risk of damage.
- Regularly examine your extension cord and ensure it is in good electrical condition. Never use a damaged cord—either replace it or have it repaired by a qualified person.
- Protect your extension cords from sharp objects, excessive heat and damp or wet areas. Keep the cord away from oil, cutting edges and moving parts.
- Do not drive, drag or place objects over cord.
- Avoid overheating. Uncoil cord and do not cover it with any material.
- Avoid accidental starting. Be sure equipment is turned off before plugging in. Do not use equipment if the power switch does not turn the equipment on and off.
- Make sure equipment is not running before disconnecting cord.
- Unplug equipment. When not in use and before changing accessories or performing maintenance, unplug the machine.

### Extension Cord Selection

All cords should be sized appropriately to reduce the risk of damage, fire or reduced performance. Reference the table in this section for cord sizes.

## ELECTRICAL PRACTICES—CONTINUED

### How to Use This Table

1. Determine your supply voltage.
2. Determine the total length of your cord including all extension cords.
3. Determine the maximum amp draw for your machine.
4. Trace your voltage across the top of the table to the first length that is greater than or equal to your cord length.
5. Follow the column down to the first row that contains a maximum amp draw greater than or equal to yours.
6. This cell contains the minimum wire size for your application.

### Example

**Application:** Max Amps = 11A, Length = 40ft, Voltage = 120V

**Solution:** 40ft is between the 25ft and 50ft columns, so the larger of the two columns is chosen. Likewise, 11A is between the 10A and 12A rows, so the larger of the two rows is chosen. 14 AWG (2.5mm<sup>2</sup>) is the minimum wire size for this example.

Single Phase Equipment				
Max Length	120V Supply	25ft (7.5m)	50ft (15m)	75ft (22.5m)
	230V Supply	50ft (15m)	100ft (30m)	150ft (45m)
Max Amps		Minimum Wire Size		
8		16 AWG (1.5mm <sup>2</sup> )	16 AWG (1.5mm <sup>2</sup> )	16 AWG (1.5mm <sup>2</sup> )
10		16 AWG (1.5mm <sup>2</sup> )	16 AWG (1.5mm <sup>2</sup> )	16 AWG (1.5mm <sup>2</sup> )
12		14 AWG (2.5mm <sup>2</sup> )	14 AWG (2.5mm <sup>2</sup> )	14 AWG (2.5mm <sup>2</sup> )
14		14 AWG (2.5mm <sup>2</sup> )	14 AWG (2.5mm <sup>2</sup> )	14 AWG (2.5mm <sup>2</sup> )

### Extension Cord Sizes

Single Phase Equipment							
Max Length	120V Supply	25ft (7.5m)	50ft (15m)	75ft (25m)	100ft (30m)	150ft (45m)	200ft (60m)
	230V Supply	50ft (15m)	100ft (30m)	150ft (45m)	200ft (60m)	300ft (90m)	400ft (120m)
Max Amps		Minimum Wire Size					
8		16 AWG (1.5mm <sup>2</sup> )	16 AWG (1.5mm <sup>2</sup> )	16 AWG (1.5mm <sup>2</sup> )	16 AWG (1.5mm <sup>2</sup> )	14 AWG (2.5mm <sup>2</sup> )	14 AWG (2.5mm <sup>2</sup> )
10		16 AWG (1.5mm <sup>2</sup> )	16 AWG (1.5mm <sup>2</sup> )	16 AWG (1.5mm <sup>2</sup> )	16 AWG (1.5mm <sup>2</sup> )	14 AWG (2.5mm <sup>2</sup> )	12 AWG (4mm <sup>2</sup> )
12		14 AWG (2.5mm <sup>2</sup> )	14 AWG (2.5mm <sup>2</sup> )	14 AWG (2.5mm <sup>2</sup> )	14 AWG (2.5mm <sup>2</sup> )	12 AWG (4mm <sup>2</sup> )	12 AWG (4mm <sup>2</sup> )
14		14 AWG (2.5mm <sup>2</sup> )	14 AWG (2.5mm <sup>2</sup> )	14 AWG (2.5mm <sup>2</sup> )	14 AWG (2.5mm <sup>2</sup> )	12 AWG (4mm <sup>2</sup> )	10 AWG (6mm <sup>2</sup> )
16		14 AWG (2.5mm <sup>2</sup> )	14 AWG (2.5mm <sup>2</sup> )	14 AWG (2.5mm <sup>2</sup> )	14 AWG (2.5mm <sup>2</sup> )	12 AWG (4mm <sup>2</sup> )	10 AWG (6mm <sup>2</sup> )
18		14 AWG (2.5mm <sup>2</sup> )	14 AWG (2.5mm <sup>2</sup> )	14 AWG (2.5mm <sup>2</sup> )	12 AWG (4mm <sup>2</sup> )	12 AWG (4mm <sup>2</sup> )	10 AWG (6mm <sup>2</sup> )
20		12 AWG (4mm <sup>2</sup> )	12 AWG (4mm <sup>2</sup> )	12 AWG (4mm <sup>2</sup> )	12 AWG (4mm <sup>2</sup> )	10 AWG (6mm <sup>2</sup> )	10 AWG (6mm <sup>2</sup> )
25		12 AWG (4mm <sup>2</sup> )	12 AWG (4mm <sup>2</sup> )	12 AWG (4mm <sup>2</sup> )	12 AWG (4mm <sup>2</sup> )	10 AWG (6mm <sup>2</sup> )	8 AWG (10mm <sup>2</sup> )
30		10 AWG (6mm <sup>2</sup> )	10 AWG (6mm <sup>2</sup> )	10 AWG (6mm <sup>2</sup> )	10 AWG (6mm <sup>2</sup> )	8 AWG (10mm <sup>2</sup> )	8 AWG (10mm <sup>2</sup> )

**Note:** The table is based on a <10% voltage loss, data from the U.S. National Electrical Code Tables 400.5(A) & 400.5(B) and typical resistances for copper wire.

# Components and Assembly

## TRANSPORT

- Secure machine with ratchet straps during transport. Proper securing straps need to be rated at least twice the weight of the machine.
- Chock wheels to keep machine from rolling, but do not use them on their own.
- Hydraulic levers should be straight up in the neutral position, not locked in the forward or backward positions.
- Lift machine off swivel caster by lowering cutting head for better stabilization. Use transport wheels when doing this.
- Remove blade, cutting head, and added weights during transport.
- Cutting head and slide plate can be removed to make machine more compact.
- Never leave machine unattended on an incline.



**CAUTION:** MACHINE IS BACK HEAVY. DO NOT RUN ON STEEP INCLINE THIS COULD CAUSE MACHINE TO TIP OVER! (FIGURE 1). DO NOT USE A RAMP TO MOVE MACHINE.



**WARNING:** MACHINE HAS A SWIVEL FRONT CASTER. NEVER SIDE HILL (FIGURE 2) THE MACHINE ON A INCLINE WITHOUT POWER, THE FRONT CASTER WILL CAUSE MACHINE TO SWING TO THE LOWEST POINT. IF IT IS NECESSARY TO RUN MACHINE ON AN INCLINE, RUN MACHINE ON CUTTING HEAD. PLACE AT LEAST A 8" CUTTING HEAD IN MACHINE. TO KEEP FROM DAMAGING FLOOR, CLAMP A PIECE OF CARPET INTO CUTTING HEAD. THIS WILL GIVE POSITIVE CONTACT WITH THE FLOOR WHEN POWER IS DISENGAGED FROM THE WHEELS.

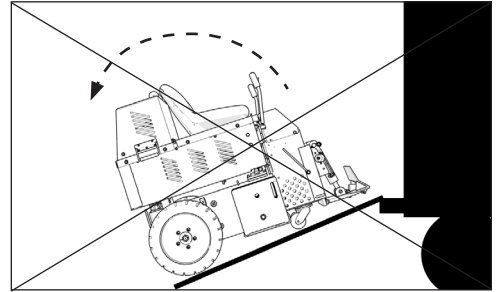

FIG. 1

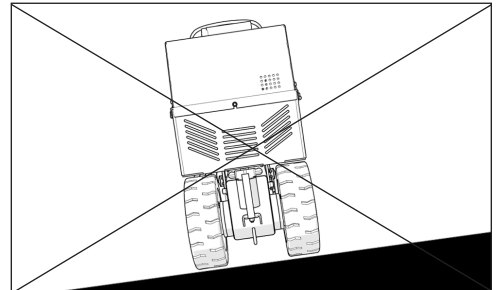

FIG. 2

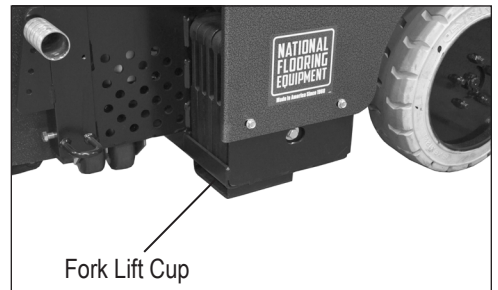

FIG. 3



FIG. 4

## Dock Heights

It is best to load or unload the machine from a level dock height.

## Power Gate

A power gate can be used when the dock height is not available. Ensure gate is properly rated for 3,000 lb (1,361 kg). To better secure machine, place onto the lowered cutting head; raise machine off the caster. Tie machine down and chock wheels.

## Forklift Cups

There are two forklift cups mounted under the front of the machine (Figure 3). Slide forklift forks through the cups, then slide as far back as possible (Figure 4). Before lifting machine, secure it to the forklift with 3,000 lb (1,361 kg) or heavier straps or a chain. Tilt forks back to lift machine.

## Palletizing

Only use a solid platform pallet. If a solid platform pallet is not available, place a piece of ¾" plywood on top of a pallet. Using a forklift, with the forks inserted in the forklift cups, place machine on pallet. Use properly rated ratchet straps to secure machine to pallet.

## JOBBSITE MOVEMENT

### Taping Wheels

Taping the wheels with a wide masking tape helps to prevent dirtying or damaging the floors during move-in and move-out.

# Components and Assembly

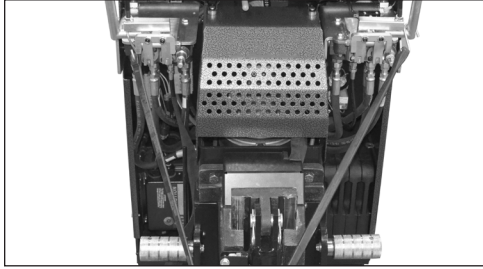

FIG. 5



FIG. 6

## Transport Wheels

The front wheel assembly is included and very helpful when moving a machine around on a jobsite or loading a machine that is not on a pallet. It allows machine stability and safe transportation over most surfaces. It is quick and easy to attach or detach.

1. Raise slide plate so the bottom of the slide plate is higher or even with the bottom of the guide channels, 6"-8" (15.25-20.3 cm) is ideal.
2. Raise cylinder; insert front wheel assembly into cutting head.
3. Secure with pin.

When finished, the caster wheels should swivel freely and the front wheel plate should be parallel with the floor.

## Moving Machine without Power (Pushing Machine)

**Forward:** To move the machine forward, levers need to be pushed forward. To lock levers in place, connect a bungee strap from each lever (pushing levers forward), pulling straps down to and connecting to the front plate (Figure 5). Never leave machine unattended with strap holding levers open.



**WARNING:** PROVIDE BARRIERS OR SHIELDS AS NEEDED TO PROTECT OTHERS FROM DEBRIS AND MACHINE OPERATION. OPERATOR SHOULD BE AWARE OF THE PROXIMITY OF OTHERS.

**Backward:** To move machine backward, levers need to be pulled backwards. To lock levers in place, connect a bungee-strap from each lever (pushing levers backward), Pulling straps to the back of the machine and connecting behind the seat or the rear of the machine (Figure 6). Never leave machine unattended with strap holding levers open.



**WARNING:** REMOVE STRAPS BEFORE STARTING MOTOR. FAILURE TO DO SO WILL MAKE MACHINE MOVE AND MAY CAUSE DAMAGE AND/OR BODILY INJURY.

## Moving Machine on Caster

Moving a weighted machine on only the front caster and not on the cutting head or the front wheel assembly can make the machine sluggish. It may also turn hard to the right or left.

## CUTTING HEAD AND BLADES

Matching the correct cutting head, blade size, blade angle, and added weight to the machine is important. For every material being removed, there is an optimum blade width, thickness, sharpness, angle, and bevel (up or down).

The machine is supplied with a 12" cutting head. Having additional cutting heads will save time on the job. Insert blades into the extra cutting heads before starting a job. When the blade is dull, take out the cutting head and replace it with another.

## Shear Point

The shear point is the point where material to be removed will cut cleanly from the floor. If the blade is too wide, too dull, or too steep the shear point is lost.

## Inserting the Cutting Head

1. With machine off, insert desired cutting head into cutting head holder.
2. Secure with cutting head clip.

# Components and Assembly

## Swivel Head

The swivel head keeps the blade in contact with the floor even when the floor is uneven. When using a flat blade, turning the head over 180° provides another sharp edge on the blade without having to replace the blade.

## Inserting or Changing Blades

Sharp blades are imperative for good performance.

1. Using a 3/4" socket wrench, loosen bolts on cutting head. Quantity of bolts will vary depending upon cutting head size.
2. Insert blade into the cutting head to back of notch (Figure 7); tighten firmly.

**Note:** A cordless 3/8" drive impact wrench will speed up this process.

## Inserting a Shank Blade

Shank blades do not require a cutting head.

1. Insert desired shank blade into cutting head holder.
2. Secure with cutting head clip.

## Self-Scoring Blades

Instead of pre-scoring a job for soft goods (e.g. carpet, vinyl, linoleum, membrane), the self-scoring blades automatically do the scoring. It is important to keep the "wings" on a self-scoring blade sharp.

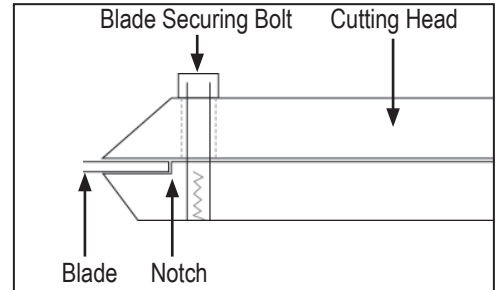

FIG. 7



**WARNING:** BLADES ARE SHARP, USE EXTREME CAUTION. ALWAYS WEAR GLOVES AND SAFETY GLASSES WHEN HANDLING BLADES. NEVER CHANGE CUTTING HEAD OR SERVICE BLADES WHILE MACHINE IS RUNNING.

# Components and Assembly

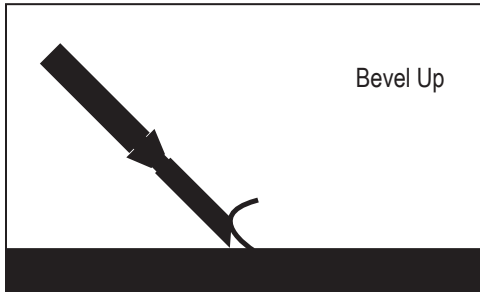

FIG. 9

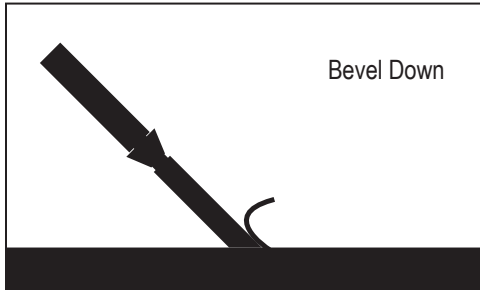

FIG. 10

## Blade Setting

- Proper blade size and placement, depending on material and sub-floor type, affects performance.
- For better results during difficult removal applications use a smaller blade.
- Start with a narrow blade, then increase blade size to optimize cutting pass. Narrower blades work easier than wider blades and usually clean the floor better. Wider is not always better or faster.
- Normally, bevel on blade is up for concrete (Figure 9); bevel down for wood (Figure 10)
- Dull blades greatly affect the performance of the machine and reduce cutting ability, sharpen or replace as needed.
- After removing a portion of material, clear the work area of debris. This will give the machine maximum performance and help to keep the work area safe.

## FOOT PEGS

Rest feet on foot pegs while operating machine. Foot pegs are adjustable. Ensure securing knob is tightened.

# Operation

## OPERATING CONTROLS

### Key Switch (Figure 11)

The key switch is used to start the machine.

### Emergency Stop Switch (Figure 11)

Push the emergency stop switch to immediately cut power to the system. It must be released in order to restart the machine. To release the switch, twist the red button and pull it upwards.

### Seat Switch

The seat has a safety switch. Operator must be properly positioned for machine to run.

### Hydraulic Levers (Figure 12)

The hydraulic levers steer the machine. For even movement, move levers slowly. Fast movement of control levers will result in jerky, uneven movement.

- To move the machine forward, push both levers forward  $\blacktriangle\blacktriangle$ .
- To move the machine in reverse, pull both levers backward  $\blacktriangledown\blacktriangledown$ .
- To turn the machine quickly to the right, move the left lever forward and the right lever backward  $\blacktriangle\blacktriangledown$ .
- To turn the machine quickly to the left, move the left lever backward and the right lever forward  $\blacktriangledown\blacktriangle$ .
- To turn the machine slowly to the right or left, push or pull only the right or left lever forward  $\blacktriangle$  or  $\blacktriangledown$ .
- Putting the levers in the center/neutral position causes the wheels to lock-up.
- Correcting direction while moving forward is accomplished by slightly reducing pressure on one lever or the other while moving.

### Cylinder Lift Lever (Figure 13)

The cylinder lift lever raises and lowers the cylinder and cutting head. After setting the slide plate to proper height, use the cylinder lift lever to set blade to proper cutting angle.

- To raise the cutting head, pull back  $\blacktriangledown$  on the cylinder lift lever.
- To lower the cutting head, push the cylinder lift lever forward  $\blacktriangle$ .
- Continuing to push the cylinder lift lever forward will adjust the angle of the cutting head. This will also jack up the front of the machine for maintenance purposes.

### Headlight

The headlight illuminates the work zone.

- Use the toggle switch to turn the headlight ON and OFF. **Note:** *The headlight only operates when the machine is running.*
- The light is fixed-mounted with fixed brightness—it is not adjustable.

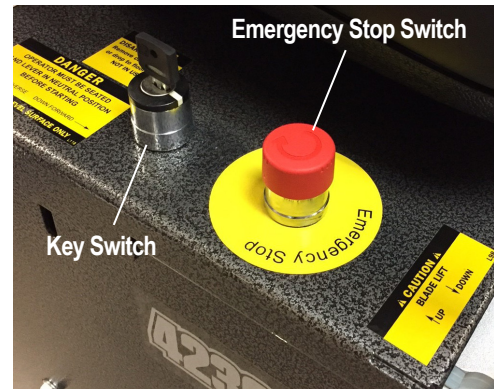

FIG. 11



FIG. 12



FIG. 13





FIG. 14



FIG. 15

## STARTUP PROCEDURE

1. Operator should be properly positioned on seat. **Note:** Operator must be seated in order to start the machine, and to keep the machine running.
2. Ensure the emergency stop switch is released.
3. Insert key into the key switch. Turn key and release once the motors start.

## SHUTDOWN PROCEDURE

The machine will stop when the operator is no longer seated, or when the emergency stop switch is pushed.

Remove blade or drop cutting head to the floor when machine is not in use.

## SLIDE PLATE ADJUSTMENT AND SETTINGS

### Manual Lift (Figure 14)



**WARNING:** WHEN ADJUSTING THE SLIDE PLATE, KEEP FEET AND HANDS OUT FROM UNDERNEATH THE CUTTING HEAD AND SLIDE PLATE. FAILURE TO DO SO COULD CAUSE SEVERE BODILY INJURY. WHEN BOLTS ARE REMOVED FROM THE SLIDE PLATE, THE CUTTING HEAD AND SLIDE PLATE WILL DROP TO THE FLOOR.

- Loosen the four bolts on the front of the slide plate with a 1-1/8" wrench. Slide plate up or down to achieve the desired height of the cutting head. Firmly tighten all four bolts when finished.
- A low setting orients the slide plate approximately 1" (2.5 cm) off the floor. This is for normal removal of most materials.
- A high setting orients the slide plate approximately 6" (15 cm) off the floor. This is for re-scraping glue and some thin-soft coatings.

### Dual Lift (Figure 15)

- Prior to adjusting the dual lift hydraulic slide plate, ensure the channel guide is free of any debris and the machine is safely positioned on a flat surface.
- To set the height of the hydraulic slide plate start, adjust the angle of the cutting head holder with the cylinder lift lever. Pull back on the cutting head lever and raise the cutting head holder to an angle higher than the bottom of the slide plate.
- The lever adjacent to the right hand control lever raises and lowers the hydraulic slide plate. To lower the slide plate, push forward on this lever. To raise the slide plate, pull back on the lever.

## Settings

While the hydraulic slide plate can be adjusted to multiple positions there are two basic slide plate settings.

- **Low Setting:** The hydraulic slide plate is positioned 1" (2.5 cm) off the floor. This setting is most commonly used during initial scraping or removal applications; such as carpet, VCT, ceramic tile and wood flooring. (Note: The "low" setting on older model hydraulic slide plates may stop the plate within one to two inches of the floors surface.)
- **High Setting:** The hydraulic slide plate is positioned 6" (15 cm) off the floor or in most cases flush with the bottom of the slide plate channel guide. This setting is most often used for re-scraping glues, mastics, thin sets and soft coating.

# Operation

## STEEP CUTTING HEAD ANGLE

A steep cutting head angle is only used for re-scraping. Raise the slide plate so the bottom of the plate is even with or higher than the bottom of the guide channels (Figure 16). If the slide plate is not raised, the operator will not have a clear view of the cutting head and the machine will be raised to an unsafe operating height (Figure 17).

**Note:** Operating the machine with a steep cutting head angle can sometimes cause the machine to jump and buck.

## APPLICATION SETUP

### Ceramic (Figure 18)

The slide plate should be adjusted to a low setting 1" (2.5 cm) off the floor. Use a shank blade or a shank blade with a carbide tip.

### Wood

The slide plate should be adjusted to a low setting 1" (2.5 cm) off the floor. Use shank blades, shank blades with carbide tips, or a 6" or 8" (15-20 cm) cutting head with heavy duty blades.

**Note:** Run machine 45° to the grain of the wood.

### Secondary Backing Carpet

The slide plate should be adjusted to a low setting 1" (2.5 cm) off the floor. Use a cutting head from 10"-27" (25-68 cm) with heavy duty blades or a cutting head from 10"-14" (25-35 cm) with a self-scoring blade.

### Foam Back Carpet

The slide plate should be adjusted to a low setting 1" (2.5 cm) off the floor. Use cutting heads from 10"-14" (25-35 cm) with self-scoring blades. If it is not stuck tight, use a cutting head from 14"-27" (35-68 cm) with a standard blade.

### Double Stick Carpet

The slide plate should be adjusted to a low setting 1" (2.5 cm) off the floor. It is best to test to see which is the easiest way to remove double stick. Start with a cutting head from 10"-14" (25-35 cm) with self-scoring blades (Figure 19). In some cases, carpet might pull off the pad and then scrape up the pad separately. Usually leaving carpet connected to the pad works the best. Sharp blades are necessary for proper operation.

**Note:** When removing carpet from over VCT tile and the tile needs to be saved, run the machine at a 45° angle over the tile. This should help to save the tile.

### Vct Tile

The slide plate should be adjusted to a low setting 1" (2.5 cm) off the floor. If goods come up easily, change to a larger cutting head. If goods come up harder, use a cutting head from 6"-8" (15-20 cm) with a premium high-tempered blade (.062) to match cutting head size. Sometimes a .094 blade may work better. If goods remove easily, a tile box (#7074) can be used. A tile box also works for wind rowing, and assists for a fast clean-up and collection of tile debris for quick removal.

### Rubber Tile

The slide plate should be adjusted to a low setting 1" (2.5 cm) off the floor. Use a cutting head from 6"-14" (15-35 cm) with self-scoring blades or use ditching method with a flat blade.

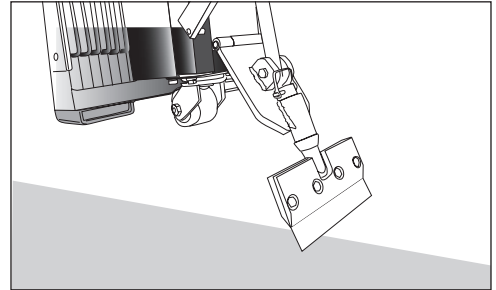

FIG. 16

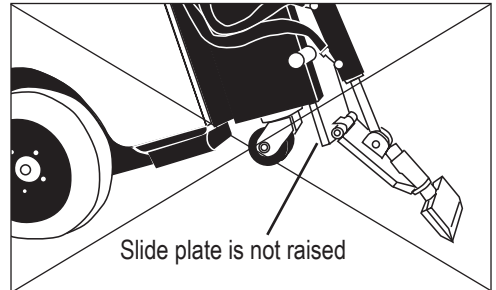

FIG. 17

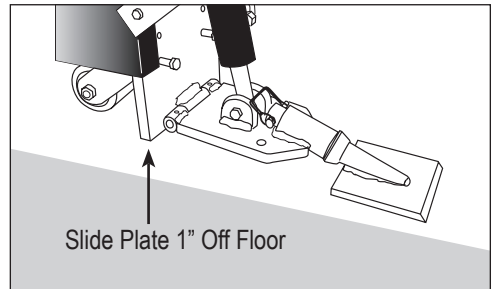

FIG. 18

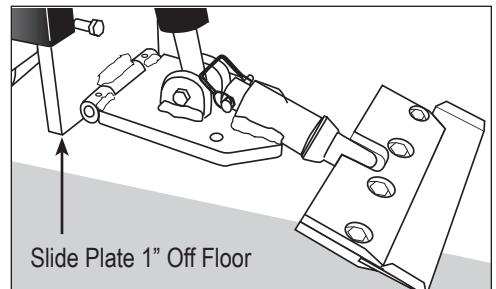
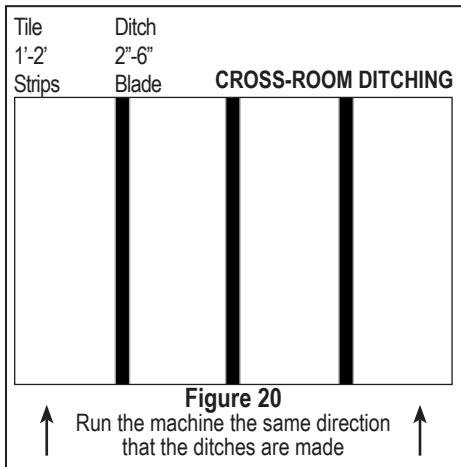

FIG. 19



## Re-Scraping

Slide plate should be set high, 6"-8" (15-20 cm) off the floor. Use a cutting head from 8"-27" (20-68 cm) with scraper blades to match cutting head size. A 15" (38 cm) scraper blade would use a 14" (34 cm) cutting head. Razor blades are faster but a cutting head from 8"-14" (20-35 cm) can be used with a standard blade. Flip head regularly.

## Thin Coating and Glues

Slide plate could be set high, 6"-8" (15-20 cm) or low 1" (2.5 cm) off the floor. Test to see which works best. Use a cutting head from 8"-27" (20-68 cm) with razor blades to match cutting head size.

## Concrete

Blade should be bevel up when working over concrete. Pretty much anything over concrete works. Try different setups to see which works best. If goods come up difficult, the slide plate should be at a low setting, 1" (2.5 cm) off the floor. Use a smaller size blade. If goods come up easily, a wider blade can be used.

## Wood Sub-Floor

A heavy machine cannot be used on wood subfloors or raised panel computer floors. Keep machine light; remove all weights. A weighted machine could break through the floor. The slide plate should be adjusted to a low setting, 1" (2.5 cm) off the floor. Blades should be as flat of an angle as possible. Use a heavy duty blade (these blades have a bend to them) or a regular blade bevel down. When using a regular blade, bending up the corners of the blade will help from the blade digging into the floor. Sometimes a shank blade or a shank blade with a carbide tip will work. Allow blade to shear material from the floor. The trick on wood floors is to run the blade flat. Approach should be at a 45° angle to the board. This keeps from digging into the board and hanging up at the seams.

## Soft Sub-Floor

The slide plate should be adjusted to a low setting 1" (2.5 cm) off the floor. Blades should be as flat of an angle as possible. Use a heavy duty blade (these blades have a bend to them) or a regular blade bevel down. When using a regular blade, bending up the corners of the blade will help from the blade digging into the floor. Sometimes a shank blade or a shank blade with a carbide tip will work.

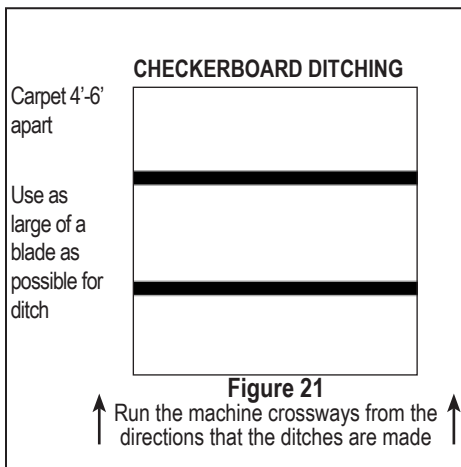

## DITCHING

### Cross Room Ditching (Figure 20)

When removing hard to remove ceramic, VCT, or VAT, cross-room ditching will help to make the removal easier. Using a blade 2"-6" (5-15 cm) in width, make ditches 1'-2' (30-60 cm) apart in the same direction the machine will be removing the goods. This relieves the pressure holding the tiles together. If ditching helps and the goods are coming up easy, try using a wider blade to ditch with.

### Checkerboard Ditching (Figure 21)

To make carpet removal and debris clean-up easier, checkerboard ditching is very helpful. Using as wide of a self-scoring blade as possible, make ditches 4'-6' (1.25-1.75 m) crossways from the way the machine will be removing the goods. Running the machine crossways from the ditches will make smaller pieces of debris to be hauled away. Instead of large gummy rolls of carpet, there are small squares that can be rolled, palletized, put on a dolly, or folded with the sticky side in. This makes removing the debris easier and reduces the amount of debris.

# Maintenance Schedule

Maintenance to be performed	Interval					
	Daily	200 hrs	1000 hrs	2000 hrs	After initial 100 hrs	After initial 500 hrs
Inspect extension cord for damage.	•					
Check wheels, caster and wheel motors for build up; and clean.	•					
Inspect all safety devices (e-stop, backup beeper, seat switch).	•					
Inspects for leaks (hoses and fittings).	•					
Blow out fan cover on the back of both motors.		•				
Grease front caster wheel.			•			
Check hydraulic oil level.		•			•	
Replace the spin-on hydraulic oil filter.		•			•	
Change hydraulic fluid.			•			•
Inspect pump shaft splines; apply anti-seize lubricant.		•				

It is recommended to perform initial maintenance during the break-in period when first operating the machine. After the first 100 operating hours the hydraulic oil level should be checked and the spin-on hydraulic oil filter should be replaced, then every 200 hours thereafter. At the 500 operating hour mark the hydraulic fluid should be changed. Regular maintenance should be performed according to the schedule.



**WARNING:** THE BACK-UP BEEPER IS ON THE MACHINE FOR SAFETY. IT IS IMPORTANT TO KEEP IT IN GOOD WORKING CONDITION. FAILURE TO DO SO COULD CAUSE BODILY INJURY.

# Troubleshooting Guide

Problem	Cause	Solution
Machine will not start.	Seat safety switch is disengaged.	Ensure operator is seated.
	Emergency stop switch is pushed.	Release emergency stop switch.
	Key switch did not fully engage.	Turn the key fully and long enough for the motors to begin running.
	Power cord is disconnected.	Ensure the power cord and extension cord are plugged in. Check cords for damage.
	External circuit breaker tripped.	Ensure no other equipment is running off the external breaker and reset the breaker.
	Internal circuit breaker tripped.	Reset the breaker within the control panel. Allow motors to cool before returning to operation. If repeated internal trips occur, contact NFE tech services for assistance.
Machine is making rattling noises.	Loose hardware on machine.	Inspect and tighten bolts as needed.
Fluid is leaking from machine.	Hose connections/or fittings have loosened through normal use.	Tighten hydraulic hoses and fittings as needed.
	Pin hole in the hoses.	Replace affected hose.
	Oil and/or oil filter are old.	Replace oil and oil filter yearly on machine.
Tires/Wheel motors make a slight clicking noise.		Normal noise with proper operation.
Machine is jerky or jumpy.	New operator.	Additional time is required to become familiar with machine.
	Control levers are being moved too quickly.	Operate control levers with wrist resting on knees for additional support or purchase arm rest.
Coupling leaks at thread or seat.	Missing or damaged O-rings.	Check for missing or damaged O-rings; replace if necessary.
	Damaged threads due to misalignment or improper seat angle.	Correct seat angle. Check for thread damage; replace if necessary.
	Over or under torquing.	Only hand-tighten hardware.
Any issues concerning the electrical box.		Must be serviced by NFE—cannot be serviced in the field. Contact tech services for assistance.
Any issues not listed above.		Contact NFE to speak with a technician.

# Maintenance

---



**WARNING:** ALWAYS DISCONNECT MACHINE FROM POWER BEFORE PERFORMING MAINTENANCE.

## MANUAL SLIDE PLATE REMOVAL



**WARNING:** SLIDE PLATE WILL DROP TO THE FLOOR WHEN SLIDE PLATE SECURING BOLTS ARE DISENGAGED. KEEP HANDS AND FEET OUT FROM UNDERNEATH SLIDE PLATE, FAILURE TO DO SO COULD CAUSE SEVERE BODILY INJURY.

1. Disconnect machine from power.
2. Remove slide plate pin.
3. Remove cutting head bolt
4. Remove cylinder from slide plate.
5. Remove slide plate.

OR

1. Disconnect machine from power.
2. Disconnect hydraulic lines from cylinder. A small amount of oil leak out of lines, place rag below line to catch fluid. Cap lines or bleed into a container. Wipe up spillage immediately.
3. With lines removed, loosen slide plate bolts. Hold slide plate at the top of the cylinder.
4. Remove slide plate, cylinder and lower cutting head support.

## DUAL SLIDE PLATE REMOVAL



**WARNING:** ASSEMBLY IS VERY HEAVY. USE TEAM LIFT OR FORKLIFT TO LIFT. KEEP HANDS AND FEET OUT FROM UNDER THE ASSEMBLY. FAILURE TO DO SO COULD CAUSE SEVERE INJURY.

1. Lower the slide plate to the floor and place a wood block under the assembly.
2. Disconnect machine from power.
3. Remove the front cylinder by taking the 1/2" bolt out of the bottom and removing the hitch clips and pin from the top of the cylinder.
4. Remove the E-clips from the pin at the bottom of the internal cylinder, then remove the pin.
5. Remove the pin from the top of the internal cylinder and then remove the cylinder from the machine.
6. Loosen the pinch bolt from the lower right side of the assembly.
7. Remove the lock nut from securing bolts at the top of the slide plate.
8. Remove the socket head screws at the top of the dual slide from both sides of the assembly.
9. Install 3/8-16x5" bolts into the holes the socket head screws were removed from. Once installed the bolts should be used as lifting handles.
10. Lift the assembly out of the machine.

## LEAK MAINTENANCE

All fittings on this machine are O-ring style.

1. Disconnect machine from power.
2. If a leak is detected, tighten fitting with the proper wrench size. Do not over-tighten. Over-tightening could damage to O-rings.

## CHECK HYDRAULIC OIL LEVEL

Check fluid level in the fill hole on the right side of the frame, in front of the rear wheel.

1. Remove filler plug.
2. Oil should be visible 1" below hole.
3. Reinsert plug.

## HYDRAULIC OIL CHANGE OUT

1. Disconnect machine from power.
2. Drain fluid by removing the drain plug from side of tank. This unit contains 6 gallons (22.7 liters) of fluid. Ensure the container size is adequate to catch fluid.
3. Replace drain plug.
4. Remove filler plug.
5. Add oil into the fill hole. Total tank capacity is 6 gallons (22.7 liters). Due to a certain amount of retained oil, the oil change refill amount is 5.5 gallons (20.8 liters). *NOTE: Adding more than this amount could cause the oil to overflow from the vent tube.*

## CHANGE TILT HYDRAULIC CYLINDER

1. Disconnect machine from power.
2. Disconnect cylinder lines. Have a container ready to catch oil from lines.
3. Remove hex head bolt securing cylinder to lower cutting head support.
4. Remove clips and pin from cylinder and slide plate.
5. Remove cylinder upper pin.
6. Remove cylinder.

## CHANGE/REMOVE HOSE

1. Disconnect machine from power.
2. Follow *Remove Front and Rear Hoods* procedure to gain access to hose (if necessary).
3. Using proper wrench size, remove hose from fitting.
4. When replacing, make sure O-ring is properly seated on hose fitting.

## CHANGE PUMP

1. Disconnect machine from power.
2. Follow *Remove Front and Rear Hoods* procedure to gain access to pump.
3. Disconnect hydraulic lines.
4. Remove two 5/16" pump securing bolts.
5. Remove pump by pulling pump straight out from pump motor.

*NOTE: Pump-to-motor alignment is critical for effective operation of machine.*

## CHANGE VALVE

1. Disconnect machine from power.
2. Follow *Remove Front and Rear Hoods* procedure to gain access to valve.
3. Remove hoses from valve body. Have a container ready to catch leakage from lines.

# Maintenance

---

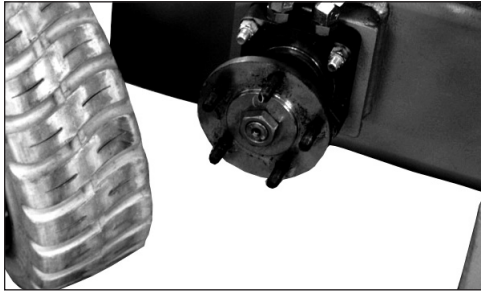

FIG. 1

4. Take notice of angle of valve fittings.
5. Remove three 5/16-18" bolts securing valve body.

## CHANGE WHEEL MOTOR

1. Disconnect machine from power.
2. Block up machine to remove wheel.
3. Remove wheel.
4. Remove oil lines from wheel motor. A small amount of oil will run out of the lines. Drain into a container. Wipe up spills immediately.
5. Remove four 1/2" wheel motor securing nuts.
6. Pull out on wheel motor to remove.

## CHANGE REAR WHEEL (FIG. 1)

1. Jack machine up by pushing the cylinder lift forward to lower and adjust the angle of the cutting head to raise machine.
2. Place blocks under forklift cups on the side of the machine that wheel is being changed.
3. Let cylinder down resting machine on blocks allowing rear wheel to be lifted off the floor.
4. Remove five 1/2" lug nuts with an extended arm wrench, remove wheel.
5. Replace wheel.
6. Replace five lug nuts and tighten to 85 ft.lbs.
7. Raise cylinder to raise machine off of blocks. Remove blocks and lower machine.
8. Repeat on other side if necessary.

## CHANGE CASTER

Keep clean and free of debris; ensure it can move freely.

1. Before replacing caster, try adding grease to zerk fitting to see if this helps caster move more freely.
2. To remove caster, machine will need to be raised. Push the cylinder lift lever forward to lower and adjust the angle of the cutting head to jack up the machine. Block up machine with wooden block. Remove four bolts, pull caster off and clean/replace as needed.
3. Replace caster.
4. Pull caster toward rear of machine; replace and tighten the four bolts.
5. Lower the machine.

## CHANGE ELECTRIC MOTOR

1. Disconnect machine from power.
2. Follow *Remove Front and Rear Hoods* procedure to gain access to motor.
3. Disconnect motor cord.
4. Remove pump.



5. Loosen screws and nuts.
6. Remove and replace motor.

## REMOVE FRONT AND REAR HOODS

1. Disconnect machine from power and extension cords.
2. Disconnect beacon harness through rear hood access hole.
3. Remove rear hood fasteners behind seat.
4. Unlatch and remove rear hood.
5. Disconnect seat harness.
6. Remove front hood fasteners.
7. Remove front hood.

## REPLACE SEAT

1. Disconnect machine from power.
2. Follow *Remove Front and Rear Hoods* procedure to remove hoods.
3. Remove four nuts securing seat rails.
4. Replace seat; replace and tighten nuts.

## REMOVE/REPLACE FOOT PEG

1. Insert a socket wrench into foot peg and secure bolt head.
2. Remove nut.
3. Remove bolt and foot peg.
4. Replace foot peg before operating machine. Do not operate machine without foot pegs.

## CLEAN WHEEL MOTOR BUILD-UP

1. Inspect the wheel motor and wheel motor hub for debris build-up (best accessed from back of machine). Remove any strands of carpet and use compressed air (not high pressure) to clean out dust or glue build-up. If any build-up cannot be removed this way, complete the following steps to remove the wheel hub.
2. Raise the front of the machine up by lowering the front cutting head down all the way, or by using 2 ton jack. Place blocks under the fork lift cup.
3. Slowly raise the cutting head until the machine is resting on the blocks and the wheel on the side that is blocked up is raised off the ground.
4. Remove the cotter pin and loosen the center wheel hub nut.
5. To loosen the wheel from the wheel motor shaft you might need to hit the steel rim from the inside with a rubber mallet.
6. Remove the wheel and remove the build up off of the wheel motor shaft.
7. Re-mount the wheel hub, making sure that the keyway matches on the motor shaft. Tighten down the wheel hub nut to press fit in the wheel hub.
8. Re-insert the cotter pin.
9. Lower the cutting head to raise the machine back off the blocks.
10. Repeat the process for the opposite side if needed.

# Parts List and Diagrams

## EXTERNAL PARTS



PART#	DESCRIPTION	QTY	PART#	DESCRIPTION	QTY
1	5200QL-25-SV PANEL, RIGHT, SILVER VEIN	1	5	5110-215 GUIDE, EXTENSION CORD	1
2	5200QL-26-SV PANEL, LEFT, SILVER VEIN (NOT SHOWN)	1	6	5110-216 CORD GUIDE BRACKET	1
3	402995-SV HOOD, FRONT, RAISED W/ DOGHOUSE, SILVER VEIN	1	7	5200QL-27 MAIN BASE (NOT SHOWN)	1
4	404653-SV HOOD, REAR, VENTED, RIDE-ON, ELECTRIC, SILVER VEIN	1			

# Parts List and Diagrams

## REAR HOOD CATCH ASSEMBLY

ITEM NO.	PART NUMBER	DESCRIPTION	QTY.
1	73008	Nut, Hex, Nylon Insert, 1/4-20	1
2	73021	Bolt, Hex Head Cap 1/4-20x2-1/4	1
3	73091	Washer, Flat, Zinc, SAE 1/4	2
4	73308	Bolt, Button Head Cap 5/16-18x3/4"	1
5	73322	Nut, Hex, Nylon Insert, 5/16-18	1
6	5200QL-31	Lever, Hood	1
7	5200QL-32	Bracket, Hood Lever	1

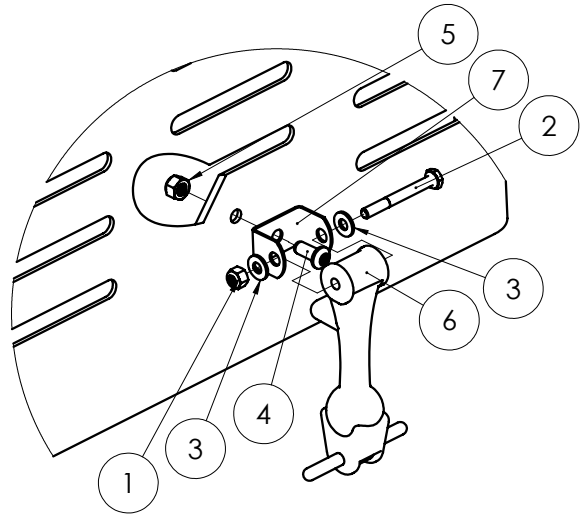

## WEIGHTS

ITEM NO.	PART NUMBER	DESCRIPTION	QTY.
1	73424	Washer, Flat, Zinc SAE 1/2	6
2	73403	Washer, Split lock 1/2	6
3	5110-404	Bottom Weight	1
4	73427	Bolt, Hex Head Cap 1/2-13x1-1/2	1
5	74854	Weight, Pocket, Cast, Ride On	10
6	73531	Washer, Flat Zinc, SAE 5/8	2
7	73414	Bolt, HHCS, 1/2-13x7	2

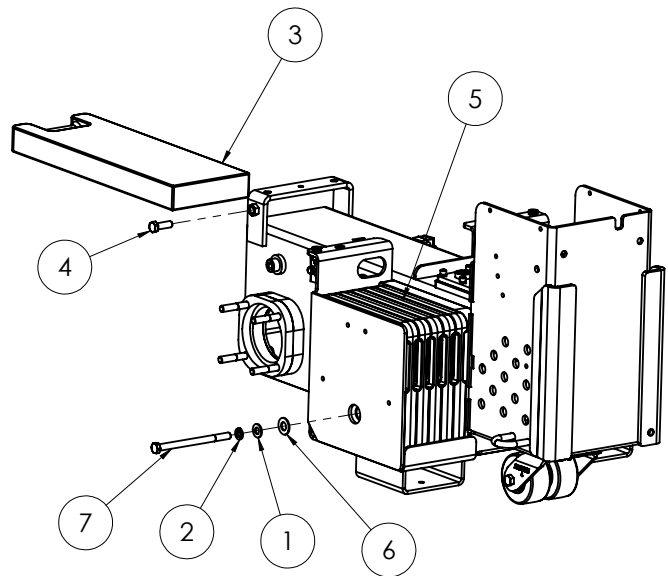

# Parts List and Diagrams

## REAR WHEEL ASSEMBLY (2X)

ITEM NO.	PART NUMBER	DESCRIPTION	QTY.
1	400133	Motor, Wheel, Hydraulic, 10mm	1
2	73047	Key, Woodruff 5/16 x 1	1
3	73402	Nut, Nylock 1/2-13	4
4	5110-117	Wheel, Hub	1
5	73430	Nut, NyLock 1/2-20	5
6	5110-405	Wheel, Rim and Tire, 18"	1
7	5110-117-2	Hub Nut	1
8	401433	Pin, Cotter 1/8 x 1.75	1

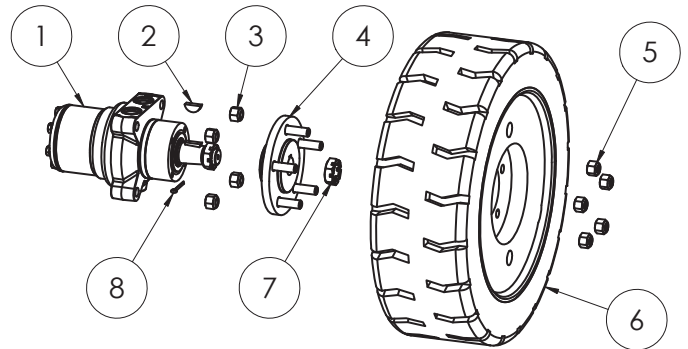

## CASTER WHEEL ASSEMBLY

Item No.	Part No.	Description	Qty.
1	402280	Caster Assy, Kingpinless, 4", Plate-Mount	1
1.1*	403352	Wheel, 4"OD x 2-1/2"W (Wheel Only)	1
1.2*	403353	Axle, Including Nut	1
2	73403	Washer, Lock, 1/2	4
3	73406	Screw, Hex Head Cap, 1/2-13x1-1/4	4
4	73424	Washer, Flat, Zinc SAE 1/2	4

\*Items 1.1 and 1.2 are included as part of Item 1 and are also available individually.

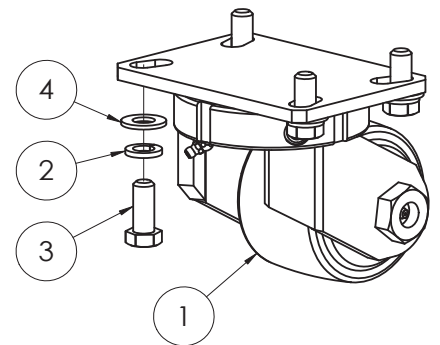

## 5110-100 TRANSPORT WHEEL ASSEMBLY

PART#	DESCRIPTION	QTY
1 5110-100W	WHEEL, TRANSPORT, CASTER ASSY, 5 INCH	2

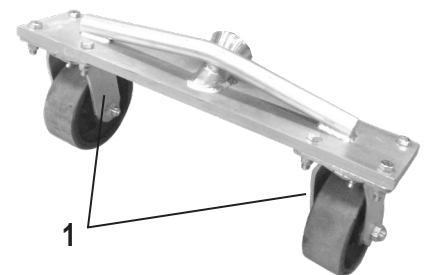

# Parts List and Diagrams

## SEAT ASSEMBLY

	PART#	DESCRIPTION	QTY
1	401631	ADJUSTER, FORE/AFT, SEAT	1
2	5110-111	SEAT, RIDE-ON	1
3	400321	ARM RESTS, KIT FOR SEAT	1
4	73322	NUT, NYLOC, 5/16-18 (NOT SHOWN)	4

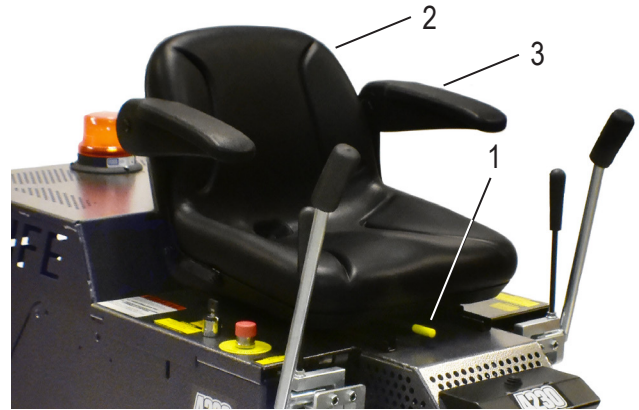

## SEAT SWITCH

	PART#	DESCRIPTION	QTY
1	5110-207	SWITCH, SEAT	1

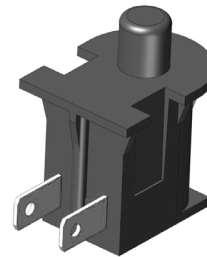

## FOOT PEG ASSEMBLY (2X)

ITEM NO.	PART NUMBER	DESCRIPTION	QTY.
1	402298	Bracket, Pivot, Footrest	1
2	73207	NUT, NYLOCK, 3/8-16	2
3	401999	Knob, Adjustable, 3/4"	1
4	5110-180	Peg, Foot	1
5	402460	Bolt, Shoulder, .500 x .75, 3/8-16	1
6	73263	WASHER, FLAT SAE ZINC 3/8	1
7	73238	Bolt, Flange 3/8-16x1-1/2	1

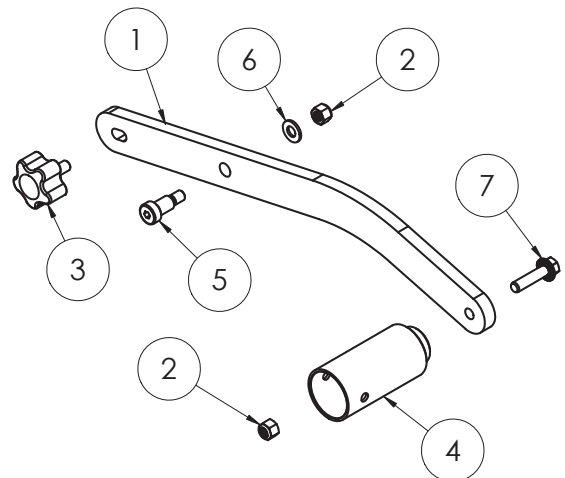

# Parts List and Diagrams

## INSTRUCTION TUBE

	PART#	DESCRIPTION	QTY
1	70602	TUBE, INSTRUCTION MANUAL	1
2	70603	CAP, INSTRUCTION TUBE	1
3	74425	NUT, KEPS LOCK 10/32	2

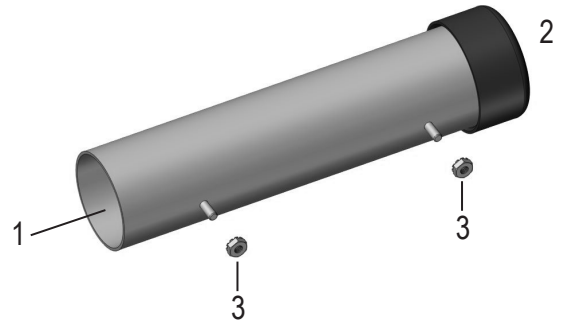

## BREATHER DIP STICK

	PART#	DESCRIPTION	QTY
1	405291	BREATHER CAP, WITH SPLASH GUARD, 1/4 NPT	1
2	402989	PIPE, RELIEF VALVE, 2-1/2"	1
3	5110-234	COUPLER, RELIEF VALVE	1
4	70655	PIPE, MALE, 10" X 3/4"	1

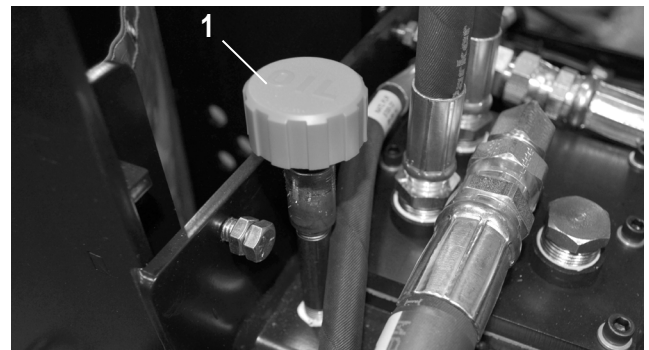

## HOSE CLAMP ASSEMBLY (2X)

	PART#	DESCRIPTION	QTY
1	5200-261-1A	CLAMP	1
2	5200-261-1B	BODY ONLY, CLAMP	2
3	73002	WASHER, SPLIT LOCK 1/4	1
4	73063	BOLT, HEX HEAD CAP 1/4-20X1-3/4	1
5	73091	WASHER, FLAT, ZINC, SAE 1/4	1

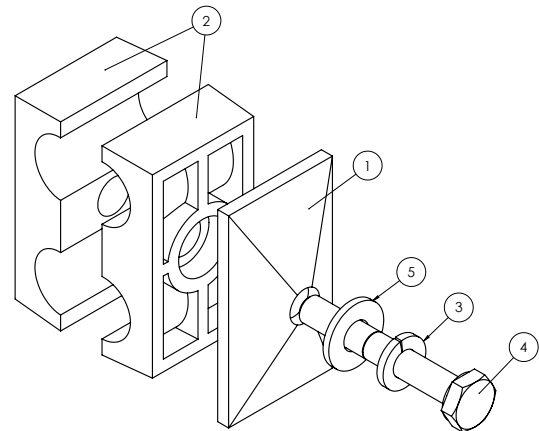

# Parts List and Diagrams

## MOTOR AND PUMP ASSEMBLY (2X)

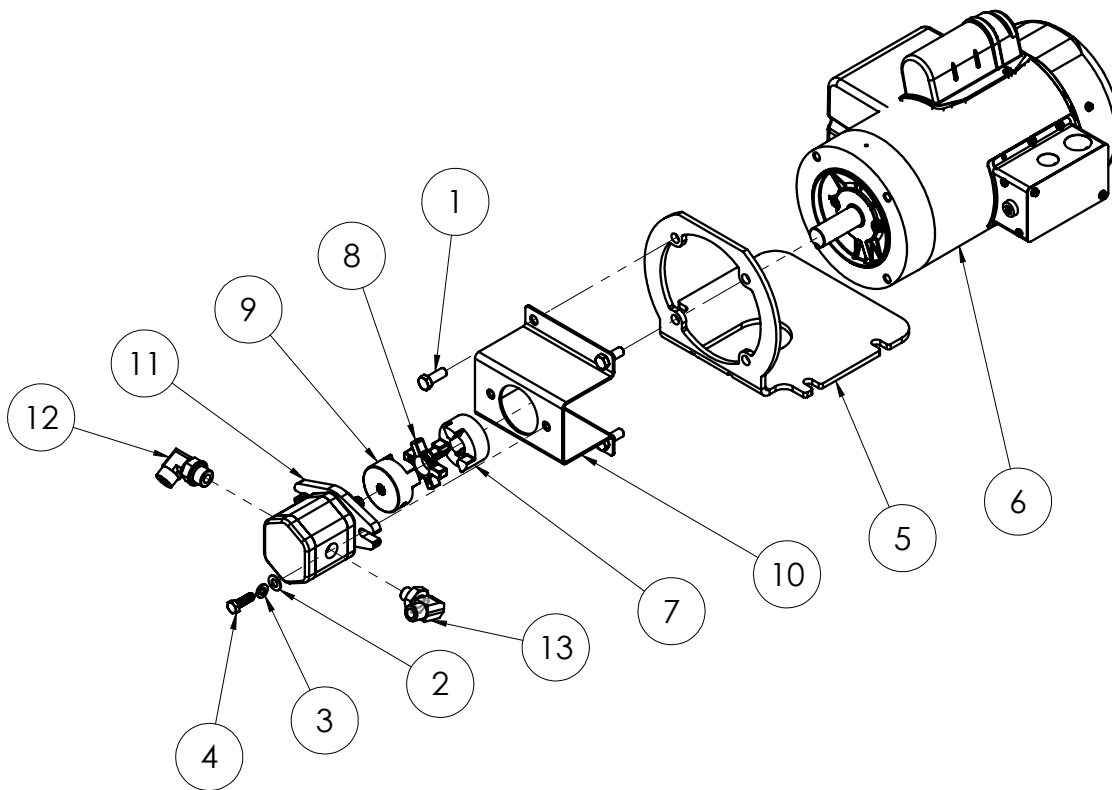

ITEM NO.	PART NUMBER	DESCRIPTION	QTY.
1	73201	Screw, Hex Head Cap, 3/8-16 x 1	6
2	73351	Washer, Flat, 5/16, SAE	2
3	73303	Washer, Split Lock, 5/16	2
4	73307	Screw, Hex Head Cap, 5/16-18x1	2
5	5110-200	Mount, Motor	1
6	72366	Motor, 1-1/2HP, 115 Volt, 1725R	1
7	70952	Coupler, Lovejoy, 7/8 Bore, 3/16 x 3/32 Keyway	1
8	70953	Coupler, Spider	1
9	70951	Coupler, Lovejoy, Splined	1
10	5110-6D	Bracket, Mounting, Pump, 3.08	1
11	404590	Pump, Hydraulic, Single #5, Splined	1
12	6280-118	Fitting, Suction Hose to Pump	1
13	72816	Fitting, Elbow, 90 Degree, 3/8"	1
14*	404674	Assembly, Motor Cord, 2.5mm/3, NEMA L6-15P	1

\*NOT SHOWN

# Parts List and Diagrams

## SPOOL AND HOSE PARTS (DUAL LIFT)

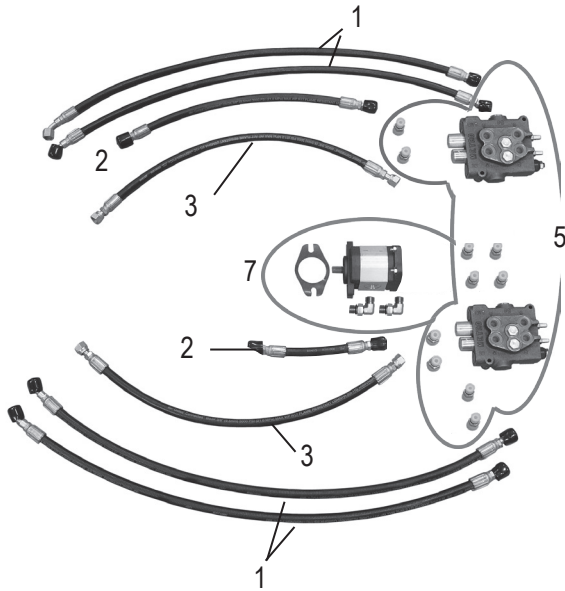

## SPOOL AND HOSE PARTS (MANUAL LIFT)

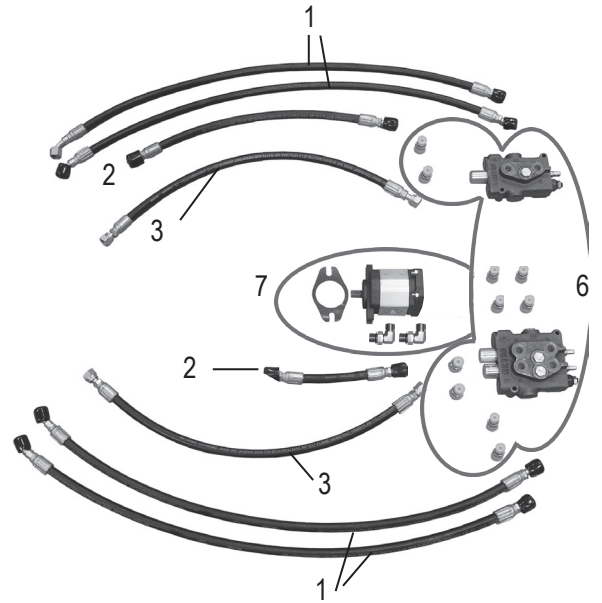

PART#	DESCRIPTION	QTY
1	5200-261 HOSE, HYDRAULIC, 3/8 X 40, F/45F	4
2	5700-72 HOSE, HYDRAULIC, 3/8 X 21, F/F	2
3	5700-75 HOSE, HYDRAULIC, 3/8 X 13, F/90F	2
4	70351 HOSE, HYDRAULIC, 3/8 X 10, F/90F	1
5	N/A SEE CONTROL LEVER PARTS (DUAL LIFT)	
6	N/A SEE CONTROL LEVER PARTS (MANUAL LIFT)	

PART#	DESCRIPTION	QTY
7	N/A SEE GEAR PUMP ASSEMBLY	
8	5110-114-2 FITTING, WHEEL MOTOR (NOT SHOWN)	4
9	5700-70 T-FITTING (NOT SHOWN)	1
10	5110-157 PLUG, DRAIN-FILLER (NOT SHOWN)	2
11	6280-162G MAGNET, TANK (NOT SHOWN)	2
12	401635 HOSE, HYDRAULIC, 3/4 X 29, F/90F (NOT SHOWN)	1



# Parts List and Diagrams

## SUCTION ASSEMBLY & FILTER

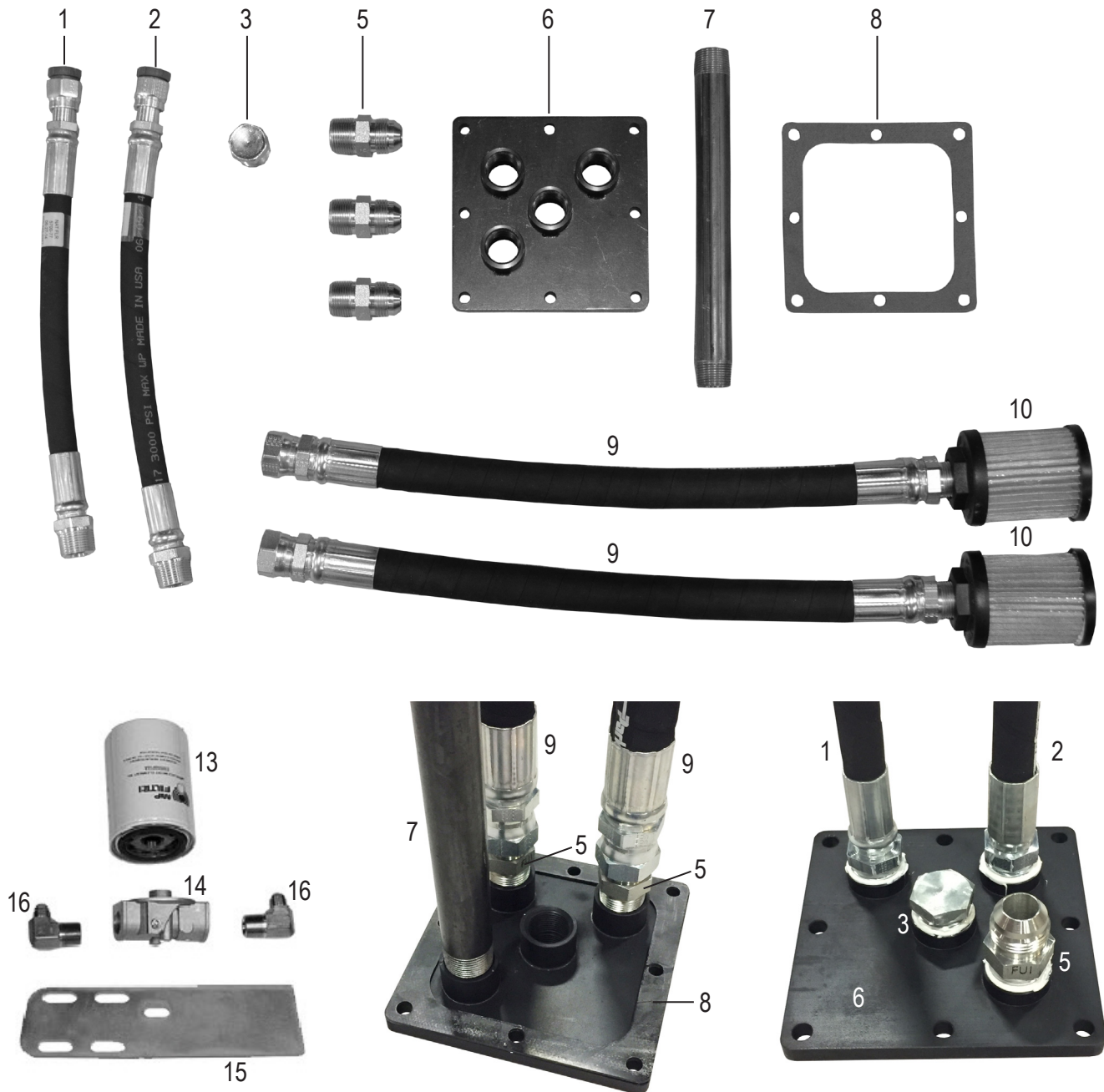

PART#	DESCRIPTION	QTY	PART#	DESCRIPTION	QTY		
1	5700-77	HOSE, HYDRAULIC, 1/2 X 13.5, M/F	1	10	5110-237	FILTER, SCREEN	2
2	5700-81	HOSE, HYDRAULIC, 1/2 X 14.5, M/F	1	11	73311	SCREW, SOCKET HEAD CAP, 5/16-18X1 (NOT SHOWN)	8
3	5700-67	PLUG, TANK	1	12	73303	WASHER, SPLIT LOCK, 5/16 (NOT SHOWN)	8
4	70654	FITTING, REDUCER (NOT SHOWN)	1	13	5700-65	FILTER, HYDRAULIC	1
5	70652	FITTING	3	14	5700-66	FILTER HEAD	1
6	401574	PLATE, SUCTION	1	15	70612	BRACKET, FILTER	1
7	70655	PIPE, MALE, 10" X 3/4"	1	16	5700-64	FITTING, FILTER	2
8	5700-93	GASKET	1				
9	400099	HOSE, HYDRAULIC, SUCTION, 3/4X20, F/M	2				

# Parts List and Diagrams

## CONTROL LEVER (DUAL LIFT)

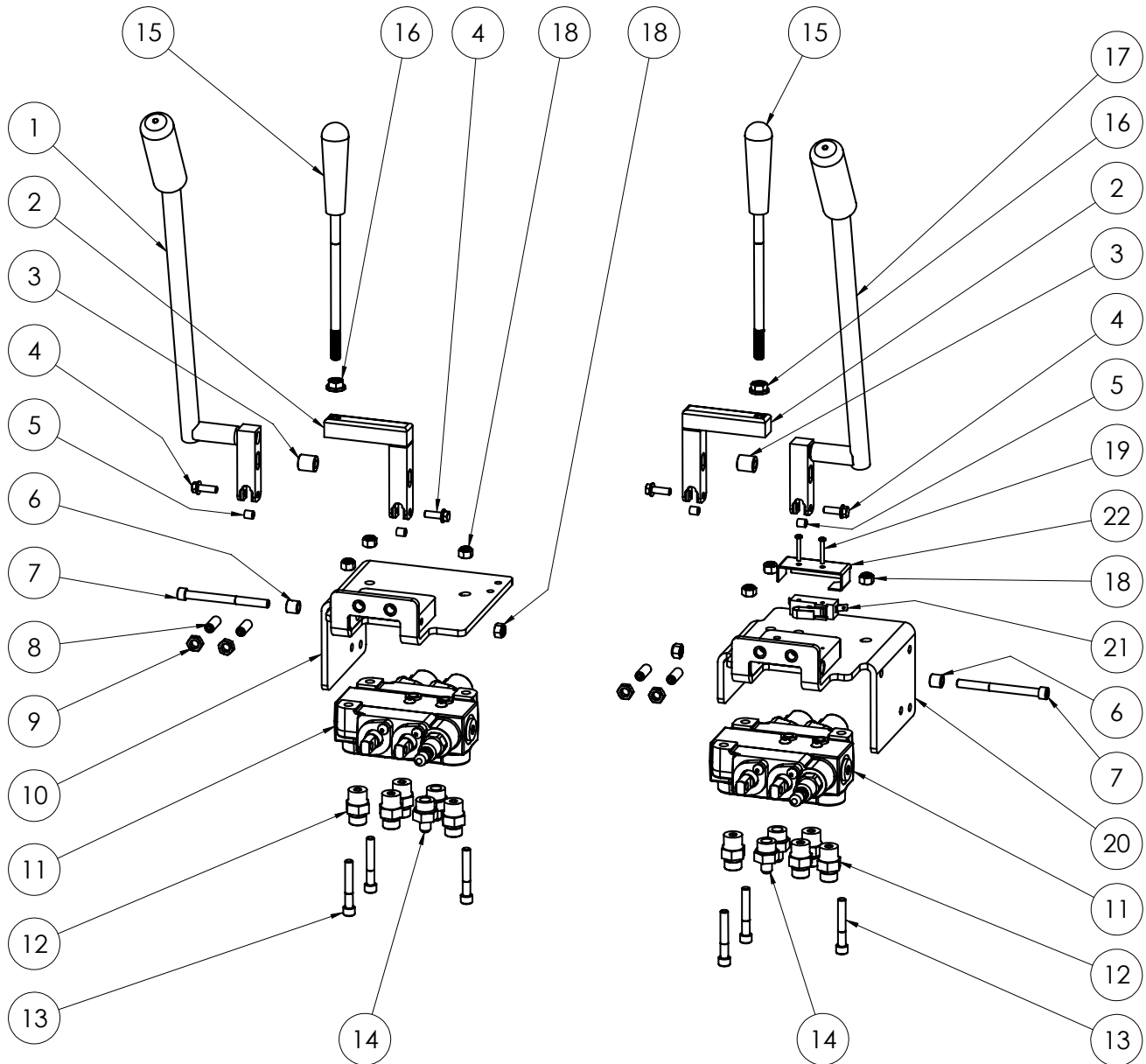

ITEM NO.	PART NUMBER	DESCRIPTION	QTY.	ITEM NO.	PART NUMBER	DESCRIPTION	QTY.
1	402416	Assembly, Valve Handle, Right	1	12	400034	Fitting, FF1231-06-08	8
2	401797	Bracket, Universal, Lever	2	13	73320	Bolt, Socket Head Cap 5/16-18x2	6
3	401408	Spacer, Round, .323 X .625 X .675	2	14	400137	Fitting, 1/2 - 1/4, JIC	4
4	73027	Bolt, Wizlock, 1/4-20 X 3/4	4	15	5700-60	Handle, Valve Adjustment	2
5	401604	Bushing, Lever, Hydro Valve	4	16	73211	Nut, Flange, Serrated, 3/8-16	2
6	402227	Sleeve, Take-up, Valve Brkt	2	17	402415	Assembly, Valve Handle, Left	1
7	73321	Bolt, SHCS, 5/16-18x3.5	2	18	73322	Nut, Nyloc, 5/16-18	8
8	73227	Screw, Set 3/8-24x1	4	19	74517	Screw, PPH-MS, 6-32x1	2
9	73235	Nut, Hex Jam 3/8-24	4	20	401795	Bracket Wldt, Valve, LH	1
10	401796	Bracket Wldt, Valve, RH	1	21	403064	Switch, Back-up Beeper	1
11	401832	Valve, Metered, Dual Spool, Low PSI	2	22	402949	Cover, Switch, Back-Up	1

# Parts List and Diagrams

## CONTROL LEVER (MANUAL LIFT)

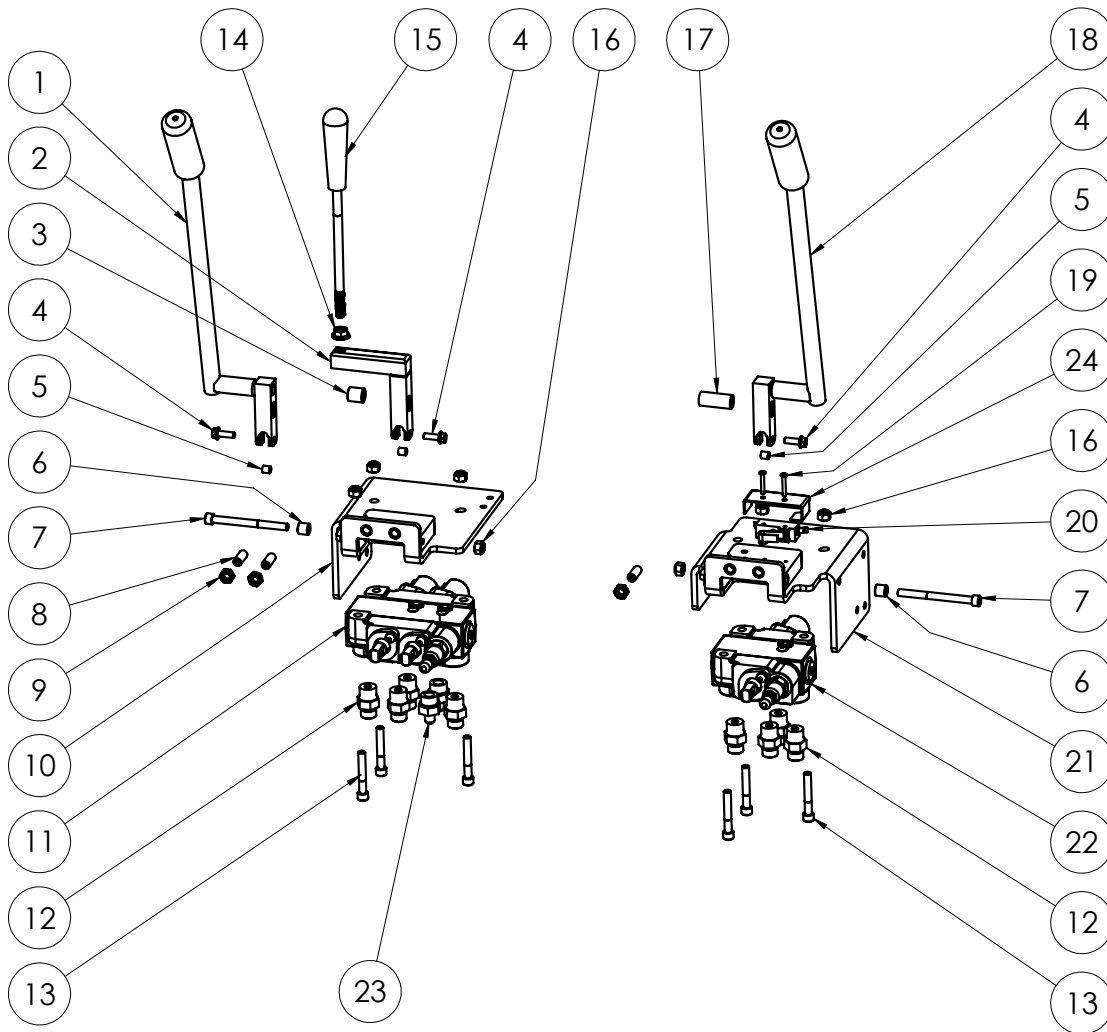

ITEM NO.	PART NUMBER	DESCRIPTION	QTY.
1	402416	Assembly, Valve Handle, Right	1
2	401797	Bracket, Universal, Lever	1
3	401408	Spacer, Round, .323 X .625 X .675	1
4	73027	Bolt, Wizlock, 1/4-20 X 3/4	3
5	401604	Bushing, Lever, Hydro Valve	3
6	402227	Sleeve, Take-up, Valve Brkt	2
7	73321	Bolt, SHCS, 5/16-18x3.5	2
8	73227	Screw, Set 3/8-24x1	3
9	73235	Nut, Hex Jam 3/8-24	3
10	401796	Bracket Wldt, Valve, RH	1
11	401832	Valve, Metered, Dual Spool, Low PSI	1

ITEM NO.	PART NUMBER	DESCRIPTION	QTY.
12	400034	Fitting, FF1231-06-08	8
13	73320	Bolt, Socket Head Cap 5/16-18x2	6
14	73211	Nut, Flange, Serrated, 3/8-16	1
15	5700-60	Handle, Valve Adjustment	1
16	73322	Nut, Nyloc, 5/16-18	7
17	401947	Spacer, Round, .323 X .625 X 1.455	1
18	402415	Assembly, Valve Handle, Left	1
19	74517	Screw, PPH-MS, 6-32x1	2
20	403064	Switch, Back-up Beeper	1
21	401795	Bracket Wldt, Valve, LH	1
22	401833	Valve, Metered, Single Spool, Low PSI	1
23	400137	Fitting, 1/2 - 1/4, JIC	2
24	402949	Cover, Switch, Back-Up	1

# Parts List and Diagrams

## DUAL SLIDE PLATE

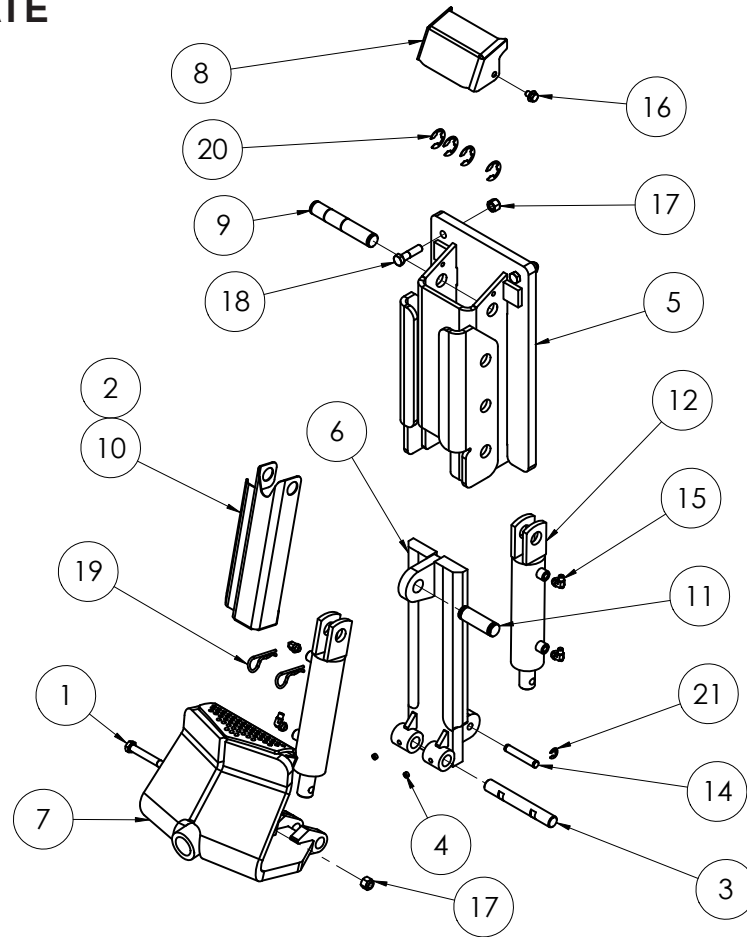

ITEM NO.	PART NO.	DESCRIPTION	QTY.
1	400132	Bolt, Hex Head, 1/2-13 x 4, Grade 8	1
2*	400296	Gasket, EPDM Foam	1
3	401429	Pin, Lower Cutting Head Support	1
4	401876	SSS, 3/8-24 x .25, Black Oxide	2
5	402423	Housing, Hydraulic Adjustment, Wldt	1
6	402432	Slide Plate, Hydraulic Adjustment, Wldt	1
7	402440	Tooling Holder, Weldment	1
8	402513	Cover, Hydraulic Adjustment, Housing	1
9	402542	Pin, Upper, Hydraulic Cylinder	1
10	402574	Shield, Cylinder	1
11	402576	Pin, Cylinder/Guard, Upper	1
12	5110-250	Cylinder NN16	2
13*	5110-267	Hose, Assembly, Hydraulic, 1/8 x 31.75, F/F	2
14	6500-31	Pin Lower Middle	1
15	72801	Fitting, 90 Deg., 1/4"	4
16	73224	Bolt, Wizlock, 3/8-16x1/2	2
17	73402	Nut, Nylock, 1/2-13	3
18	73413	Bolt, Hex Head 1/2-13x2	2
19	73536	5/8 Hitch Pin Clip	2
20	80083	E-Clip, 1" shaft	4
21	80084	E-Clip, 1/2" shaft	2

\*Not shown

# Parts List and Diagrams

## MANUAL SLIDE PLATE

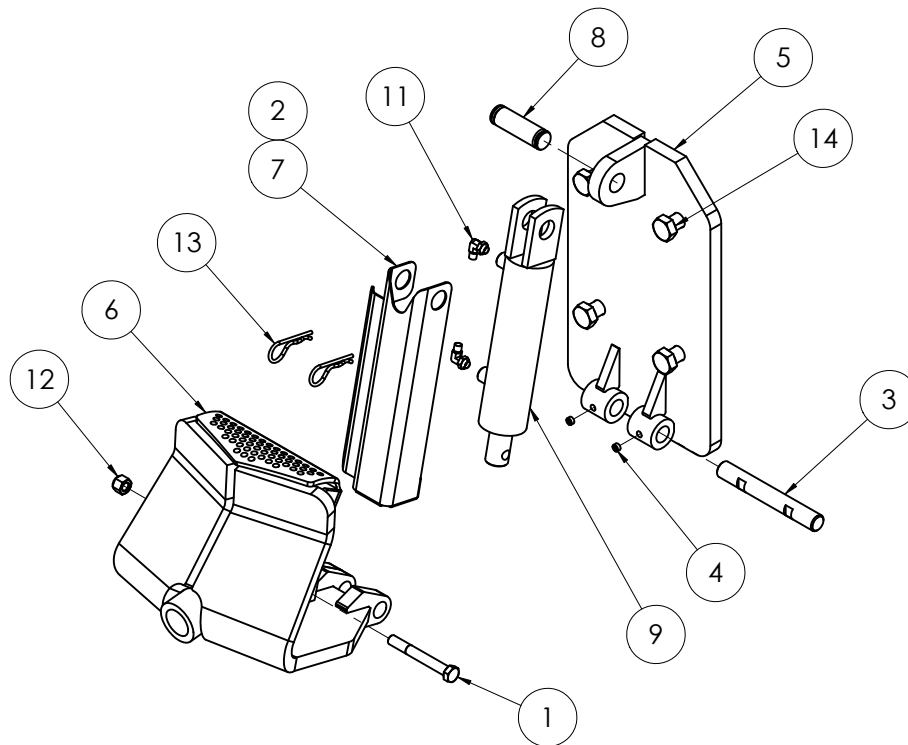

ITEM NO.	PART NO.	DESCRIPTION	QTY.
1	400132	Bolt, Hex Head, 1/2-13 x 4, Grade 8	1
2*	400296	Gasket, EPDM Foam	1
3	401429	Pin, Lower Cutting Head Support	1
4	401876	SSS, 3/8-24 x .25, Black Oxide	2
5	402410	Slide Plate, Steel, Manual Adjustment	1
6	402440	Tooling Holder, Weldment	1
7	402574	Shield, Cylinder	1
8	402576	Pin, Cylinder/Guard, Upper	1
9	5110-250	Cylinder NN16	1
10*	5110-267	Hose, Assembly, Hydraulic, 1/8 x 31.75, F/F	1
11	72801	Fitting, 90 Deg., 1/4"	2
12	73402	Nut, Nylock, 1/2-13	1
13	73536	5/8 Hitch Pin Clip	2
14	73605	Bolt, Hex Head, Grade 8, 3/4-10x1-1/2	4

\*Not shown

# Parts List and Diagrams

## 404696 CONTROL PANEL

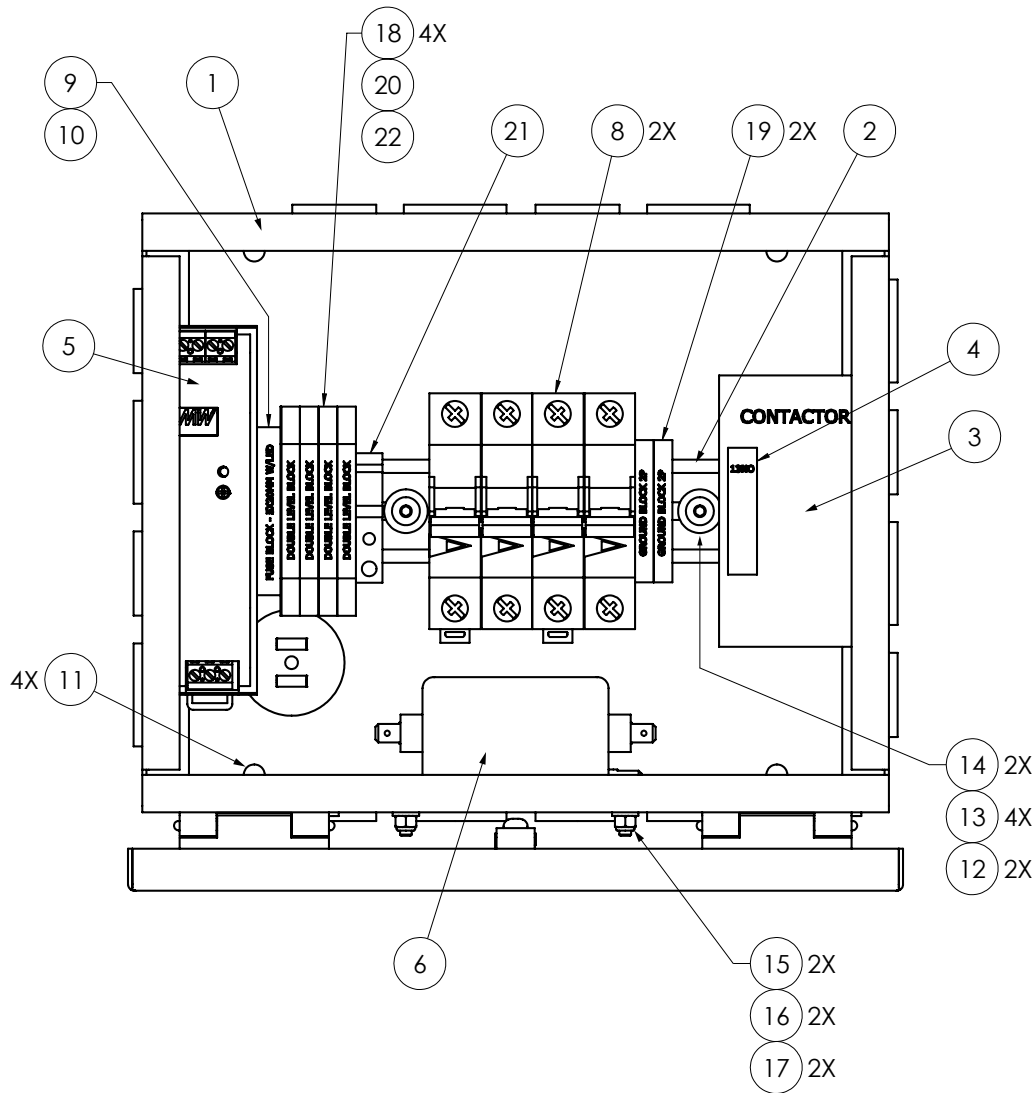

ITEM NO.	PART NUMBER	DESCRIPTION	QTY.	ITEM NO.	PART NUMBER	DESCRIPTION	QTY.
1	404586	Electrical Box, Modified, Ride-on, Electric	1	14	403279	Screw, Button Head Cap, M5-0.8 x 12, Clear Zinc	2
2	404684	DIN Rail, Top Hat, 35mm x 7.5mm x 240mm	1	15	403075	Screw, Phillips Pan Head, M4-0.7x10, Clear Zinc	2
3	404678	Contactor, 4P, 30A, DIN	1	16	403170	Nut, Hex, Nylon Insert, M4-0.7, Clear Zinc	2
4	404679	Aux Contact, NO, 6A@24V	1	17	401326	Washer, Flat, M4, Clear Zinc	2
5	404682	Power Supply, 24V, 75W, DIN	1	18	404685	Terminal Block, Double Level, Feed-Through, Spring	4
6	404713	Filter, EMI, 20A, 2MHz peak	1	19	404686	Ground Block, 2P, Screw Terminal	2
7*	404676	Wire Kit, Control Panel	1	20	404687	Jumper, Altech, Spring Block	1
8	404677	Circuit Breaker, 2P, 10A, DIN, D Trip	2	21	404718	End Stop, Terminal Block, DIN Rail, 35mm	1
9	404680	Fuse Block, 1P, LED, 90-240V, 5x20mm, DIN	1	22	404698	End Plate, Terminal Block, DIN Rail, CXDL Series	1
10	404681	Fuse, 2A, 250V, 5x20mm	1	23*	404670	Harness, Control Panel	1
11	404688	Plug, Hole, .28in ID	4	24*	404693	Assembly, Motor Cord, Control Panel, 17.5in	1
12	401517	Nut, Hex, Nylon Insert, M5-.80, Clear Zinc	2	25*	404694	Assembly, Motor Cord, Control Panel, 15in	1
13	404689	Washer, Fender, M5, Zinc-Plated	4	26*	404675	Assembly, Power Cord, 2.5mm/3, EU1-16P, 30in	1

\*NOT SHOWN

# Parts List and Diagrams

## REAR SHROUD HARNESS

	PART#	DESCRIPTION	QTY
1	404671	HARNESS, REAR SHROUD	1

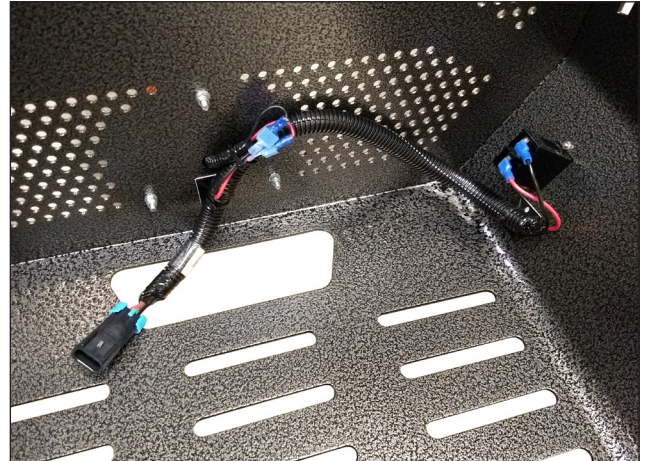

## SIDE PANEL HARNESS

	PART#	DESCRIPTION	QTY
1	404672	HARNESS, SIDE PANEL	1

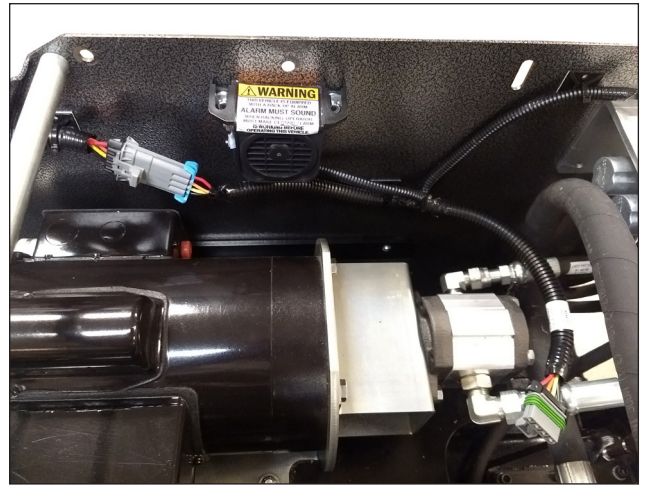

## SEAT HARNESS

	PART#	DESCRIPTION	QTY
1	404673	HARNESS, SEAT	1

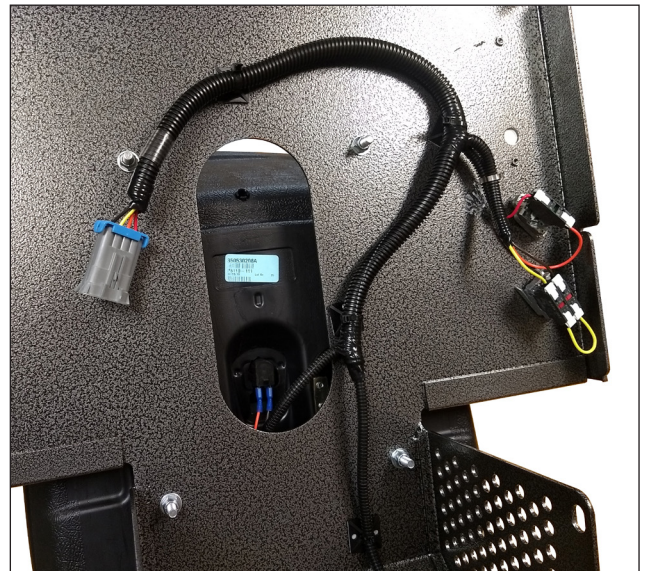

# Parts List and Diagrams

## POWER CONTROLS

	PART#	DESCRIPTION	QTY
1	401415	ASSEMBLY, KEYED SWITCH	1
	72451*	CONTACT BLOCK, NO, 10A, SPRING	
		CLAMP, ZB4 SERIES	1
	72455	SWITCH, KEYED	1
	72456*	COLLAR, MOUNTING, 22MM, ZB4 SERIES	1
2	5700-102	ASSEMBLY, E-STOP	1
	72452*	CONTACT, NORMALLY CLOSED	2
	72453	PUSH BUTTON, RED	1
	72456*	COLLAR, BODY MOUNTING	1
	5700-102D	PLATE, EMERGENCY STOP	1

\*NOT SHOWN

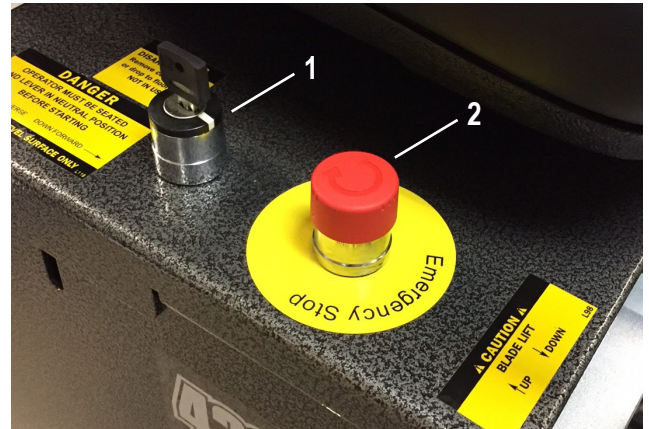

## HOUR METER

	PART#	DESCRIPTION	QTY
1	5700-88	METER, HOUR	1



## BACKUP BEEPER ASSEMBLY

	PART#	DESCRIPTION	QTY
1	5200-116	BEEPER, BACK UP	1
2	73020	BOLT, WIZLOCK, 1/4-20X5/8	2





# Parts List and Diagrams

## BEACON ASSEMBLY

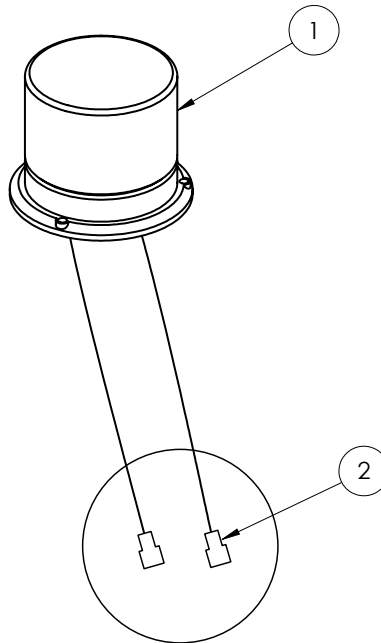

ITEM NO.	PART NUMBER	DESCRIPTION	QTY.
1	70629	Light, Flashing	1
2	72815	Terminal, Disconnect, .25", Female, 14-16AWG	2

## 404734 HEADLIGHT ASSEMBLY

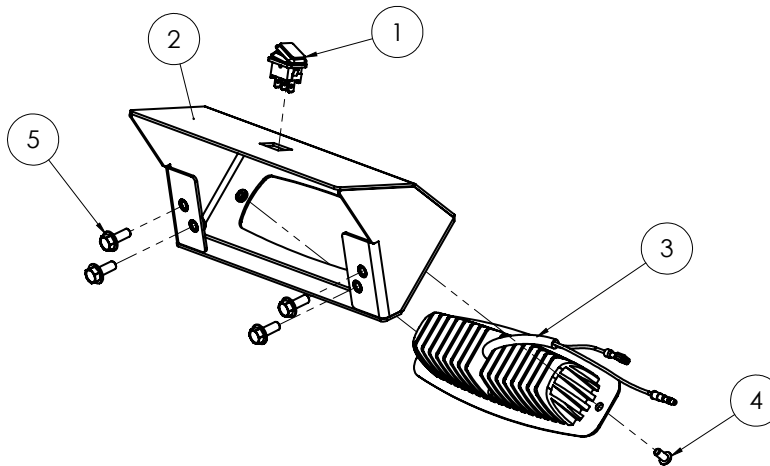

ITEM NO.	PART NUMBER	DESCRIPTION	QTY.
1	403976	Switch, Rocker, SP, 14V, 16A	1
2	404037	Shroud, Worklight, Rider	1
3	404041	Light, Work, 6"x2", Flush, 18W	1
4	404060	Screw, Button Head Cap, M5-0.8 x 10, Black Oxide	2
5	74631	Bolt, Wizlock, M6-1.0 x 16, Plain	4

# Parts List and Diagrams

## LABELS

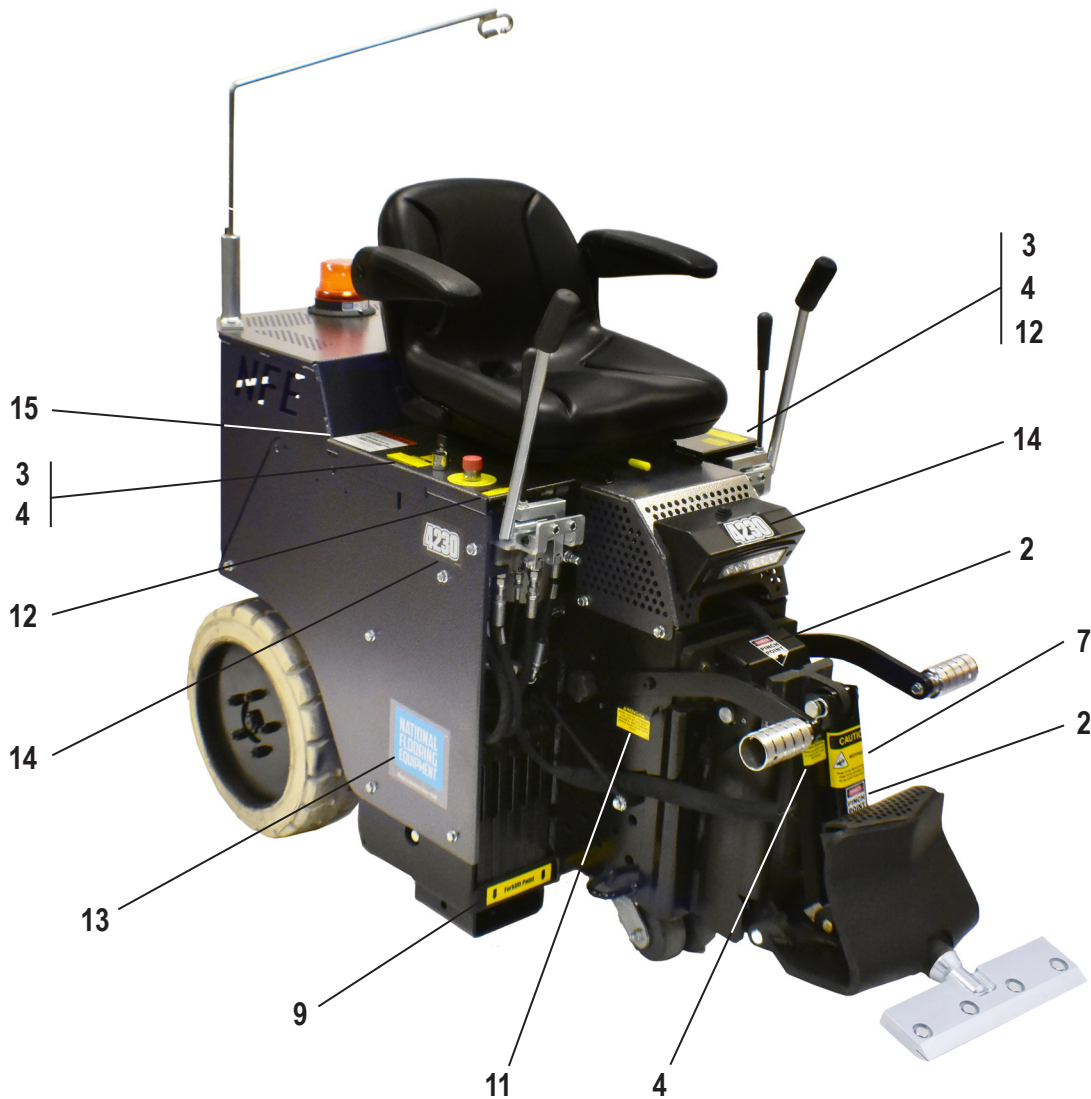

PART#	DESCRIPTION	QTY	PART#	DESCRIPTION	QTY
1	L08-1* LABEL, STAND CLEAR	2	10	L66* LABEL, LARGE CAUTION	1
2	L106 LABEL, PINCH POINT	2	11	L95F LABEL, FLUID LEAK	2
3	L118 LABEL, OPERATOR MUST BE SEATED	2	12	L98 LABEL, BLADE LIFT	2
4	L137 LABEL, DISARM MACHINE	3	13	402464 LABEL, NATIONAL LOGO, 5.5 X 6	2
5	L155* LABEL, GENERAL WARNING	1	14	404667 LABEL, 4230	3
6	L223* LABEL, PATENT	1	15	402376 LABEL, RIDE-ON LIFT	1
7	L33B LABEL, CAUTION MOVING PART	1	16	404666* LABEL, CE, 4230, 220V, 50 HZ	1
8	L33C* LABEL, INSTRUCTION MANUAL	1	17	402045* LABEL, HI VOLTAGE WARN	1
9	402149 LABEL, FORKLIFT POINT	2	18	L142* LABEL, TRAILER HITCH	1

\*NOT SHOWN

# Parts List and Diagrams

4230 Wiring Diagram  
Control Panel

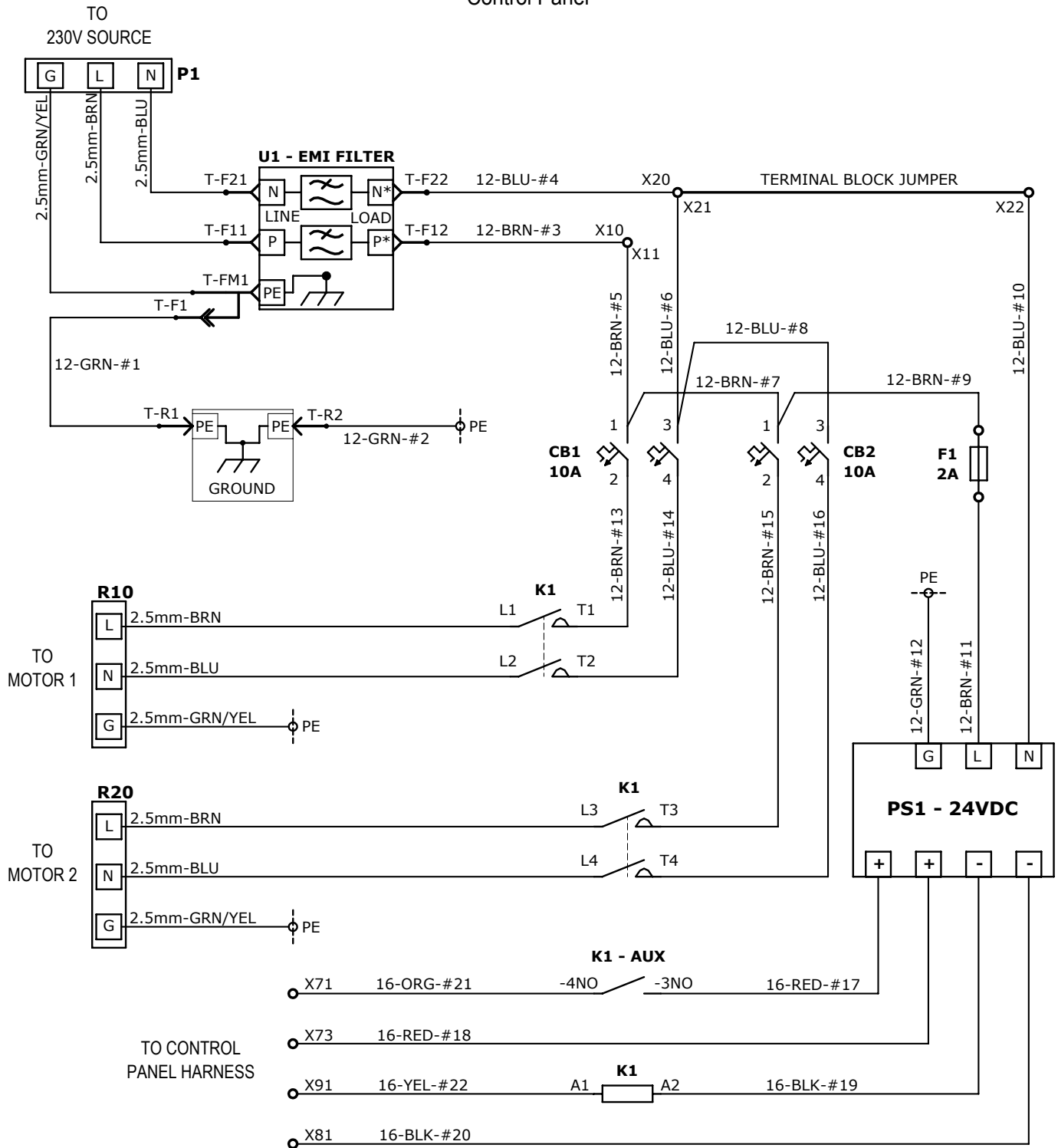

# Parts List and Diagrams

## 4230 Wiring Diagrams Control Panel Harness

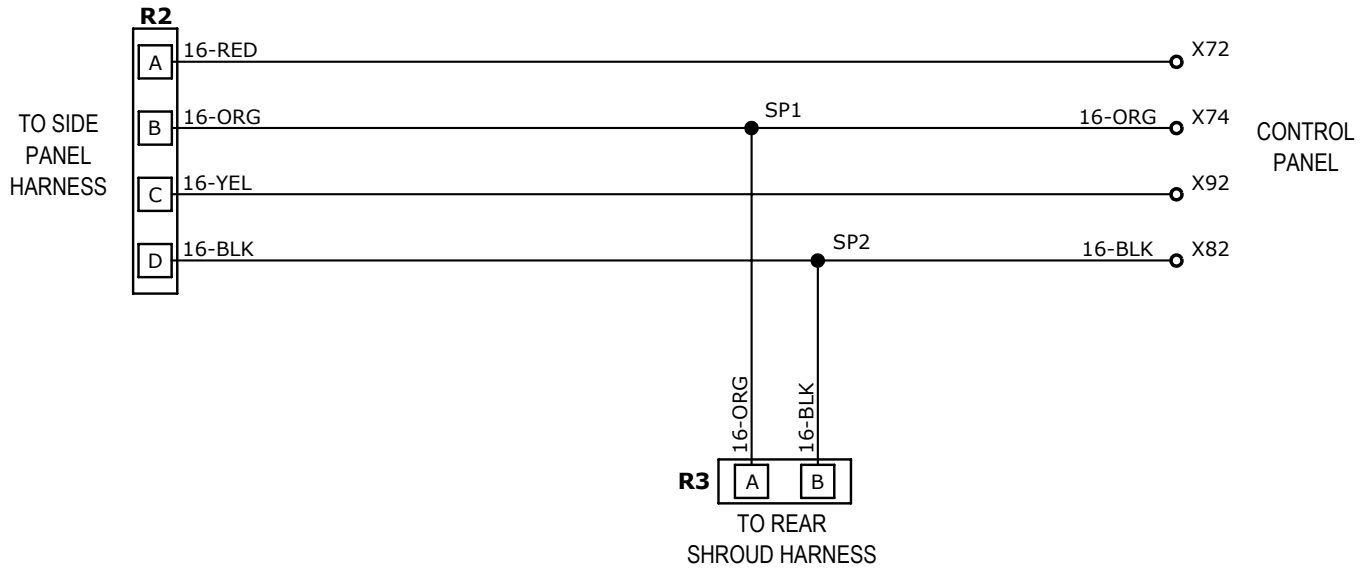

## Rear Shroud Harness

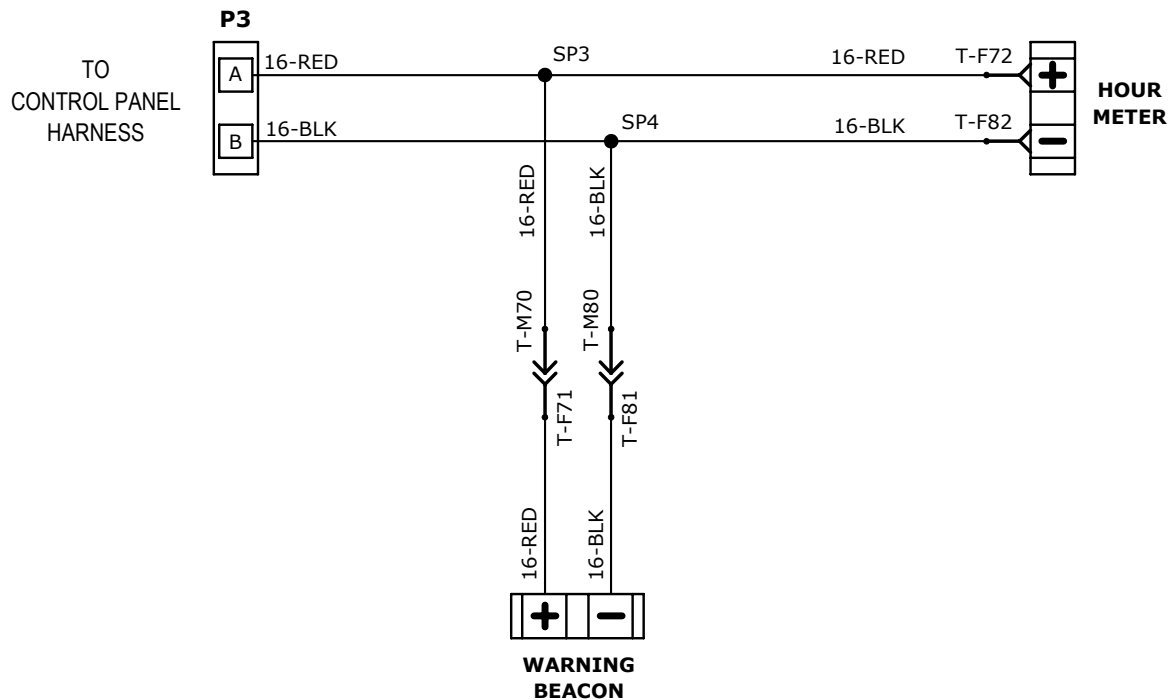

# Parts List and Diagrams

4230 Wiring Diagram  
Seat Harness

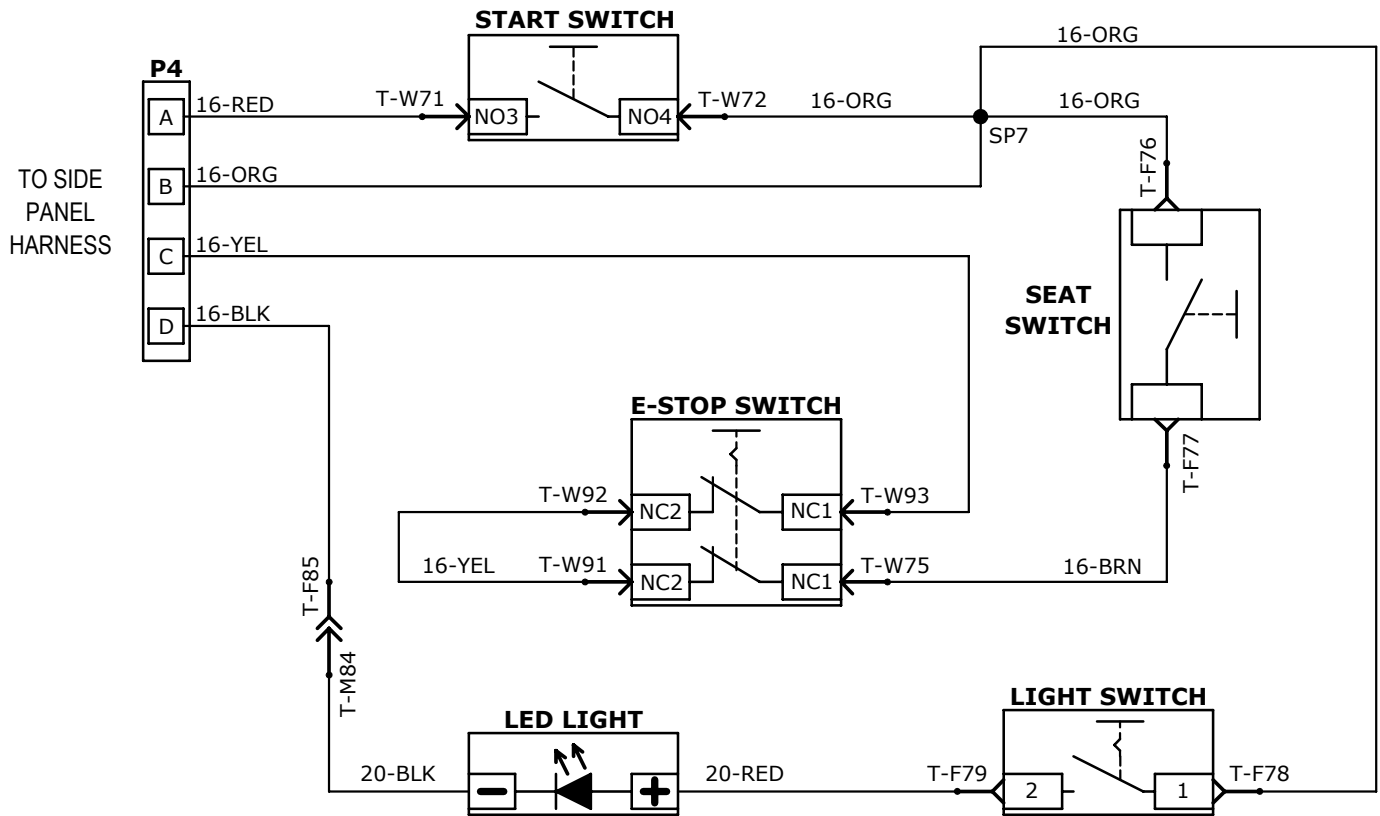

# Parts List and Diagrams

4230 Wiring Diagrams  
Side Panel Harness

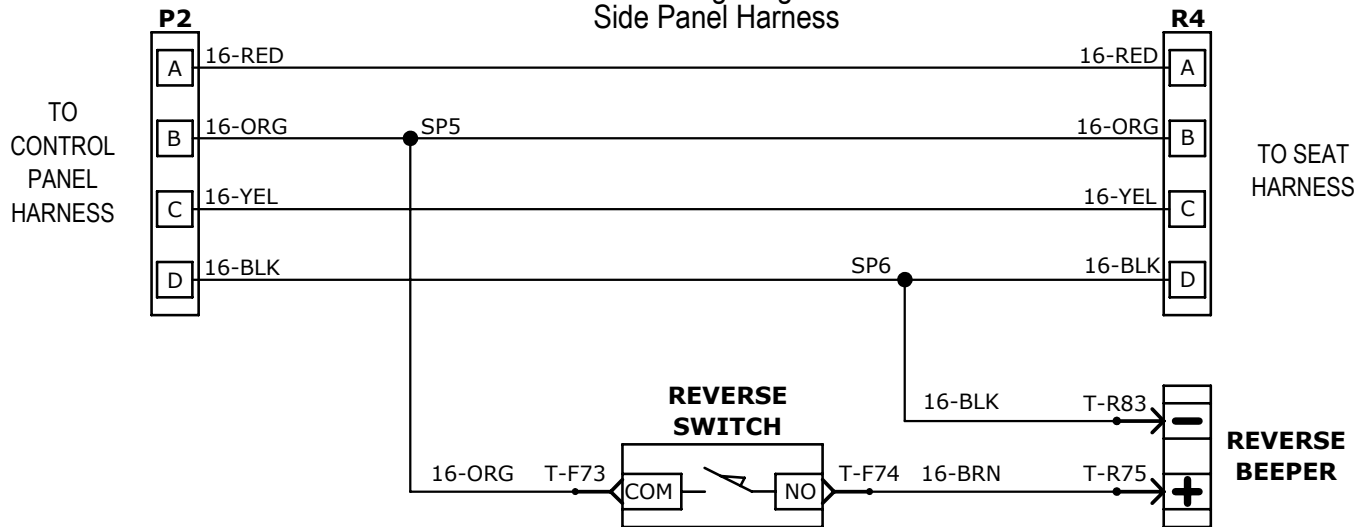

Motor Wiring

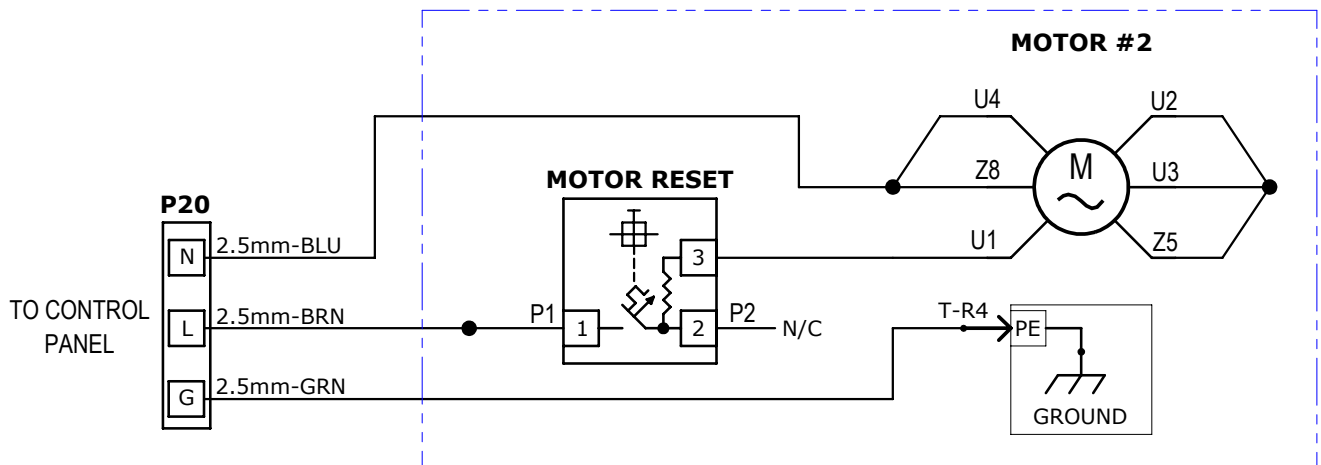
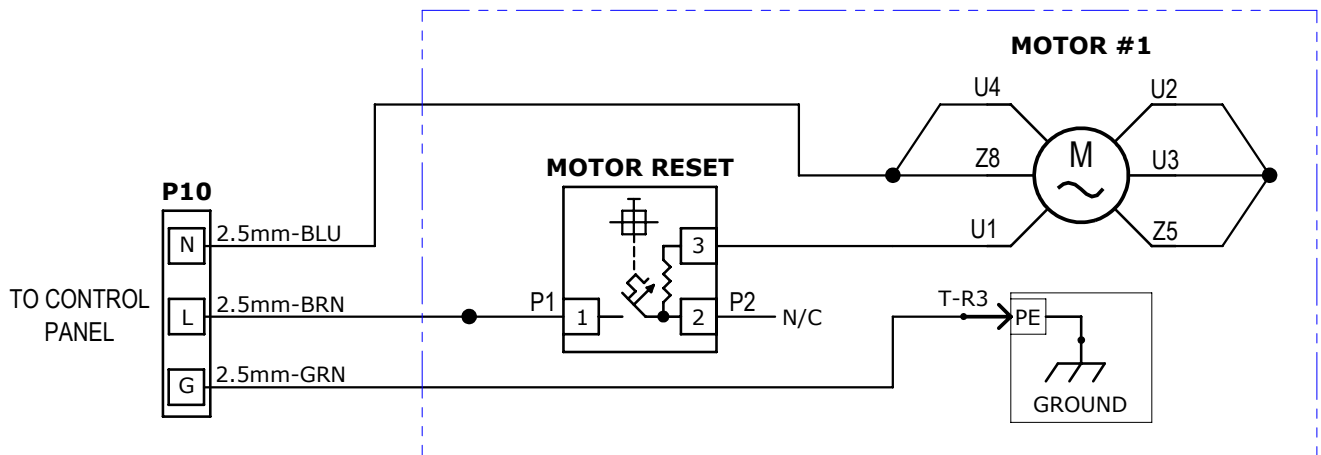





Made in America Since 1968

9250 Xylon Avenue N • Minneapolis, MN 55445 • U.S.A.  
Toll-free 800-245-0267 • Phone 763-315-5300 • Fax 800-648-7124 • Fax 763-535-8255  
Web Site: [www.nationalequipmentdirect.com](http://www.nationalequipmentdirect.com) • E-Mail: [info@nationalequipment.com](mailto:info@nationalequipment.com)